

ORDINANCE NO. 26-07

AN ORDINANCE OF THE CITY OF OCEAN CITY, COUNTY OF CAPE MAY AND  
STATE OF NEW JERSEY, AMENDING THE MUNICIPAL CODE TO PROHIBIT THE  
PARKING OF COMMERCIAL VEHICLES ADJACENT TO MUNICIPAL  
PLAYGROUNDS AND RECREATION FIELDS

WHEREAS, the City Council of the City of Ocean City finds that the parking of large commercial vehicles adjacent to areas frequented by children, specifically playgrounds and recreation fields, creates significant visual obstructions; and

WHEREAS, maintaining maximum visibility in these areas is critical for the safety and supervision of children and to ensure that law enforcement and the public can clearly monitor activity within these recreational zones; and

WHEREAS, New Jersey law, including N.J.S.A. 39:4-197, grants municipalities the authority to regulate the stopping and parking of vehicles for the safety of the public.

NOW, THEREFORE, BE IT ORDAINED by the City Council of the City of Ocean City that §4-32 "Parking of Commercial Vehicles, Boats and Boat Trailers" to read as follows:

**Section 1.**

§4-32 h. The parking of commercial vehicles, trailers and construction vehicles adjacent to municipal playgrounds and recreation fields is prohibited.

1. As used in this section, the following definitions apply:

COMMERCIAL VEHICLE: Includes, but is not limited to, any motor vehicle, trailer or semi-trailer designed, used or maintained primarily for the transportation of property, goods, or passengers for financial compensation, or as part of a commercial enterprise. This term explicitly includes, but is not limited to (a) vehicles with a Gross Vehicle Weight Rating (GVWR) exceeding 10,000 pounds; (b) vehicles designed to transport more than 8 passengers, including the driver, for compensation; (c) vehicles displaying commercial advertising, logos or USDOT registration numbers; (d) delivery vans, box trucks, tow trucks, semi-tractors, trailers, and heavy construction equipment.

CONSTRUCTION VEHICLE/EQUIPMENT: Includes, but is not limited to, backhoes, bulldozers, mixers, chippers, dump trucks with a gross vehicle weight exceeding 7,000 pounds, and any vehicle primarily designed or used for construction or demolition.

TRAILER: Any vehicle without an engine or power source designed to be transported by attachment to a motor vehicle, including but not limited to utility trailers, landscaping trailers, commercial trailers, and boat trailers.

RECREATION ZONE: Any municipal playground, park, athletic field, or recreational facility owned or operated by the City of Ocean City or Ocean City School District.

2. Parking Prohibitions.

No person shall park, store, or leave standing any commercial vehicle, construction vehicle, construction equipment, or trailer on any public street, alley or right-of-way where

any part of such vehicle, equipment or trailer is within fifty (50) feet of the property line of any Recreation Zone as defined herein.

3. Exemptions.

The provisions of this section shall not apply to;

- A. Emergency vehicles, including police, fire and ambulance equipment, while responding to an emergency.
- B. Vehicles owned and operated by the City of Ocean City, the Ocean City School District, or any public utility while actively engaged in official duties, maintenance or repair work.
- C. Commercial or construction vehicles actively engaged in the expedited loading or unloading of passengers or materials, or while actively rendering commercial services to a property within the prohibited zone.

**Section 3.**

All ordinances or portions thereof inconsistent with this ordinance are repealed to the extent of such inconsistency.

**Section 4.**

If any portion of this ordinance is declared to be invalid by a court of competent jurisdiction, it shall not affect the remaining portions of the ordinance which shall remain in full force and effect.

**Section 5.**

This Ordinance shall take effect in the time and manner prescribed by law.

\_\_\_\_\_  
Jay A. Gillian, Mayor

\_\_\_\_\_  
Terry Crowley, Jr. Council President

The above Ordinance was passed by the Council of Ocean City, New Jersey, at a meeting of said Council held on the 21<sup>st</sup> day of May, 2026 and was taken up for a second reading and final passage at a meeting of said Council held on the 11<sup>th</sup> day of June, 2026 in Council Chambers, City Hall, Ocean City, New Jersey, at six o'clock in the evening.

\_\_\_\_\_  
Melissa G. Rasner, City Clerk

5.19.26 Prohibits commercial vehicles, as defined, from parking adjacent to fields and playgrounds.

CITY OF OCEAN CITY  
CAPE MAY COUNTY, NEW JERSEY

**RESOLUTION**

No. 26-146

**AUTHORIZING A CLOSED EXECUTIVE SESSION FOR THE  
PURPOSE OF DISCUSSING PENDING LITIGATION  
(Ryan Scharff vs. City of Ocean City, et al.)**

**WHEREAS**, the Open Public Meetings Act provides for the closing of public meetings by way of Resolution under certain circumstances, as provided in that Act, and when the governing body determines that it is in the public interest to close said meeting; and

**WHEREAS**, the City of Ocean City is a defendant in the matter of *Ryan Scharff vs. City of Ocean City, et als.*

**NOW, THEREFORE, BE IT RESOLVED** by the City Council of the City of Ocean City, County of Cape May, New Jersey that this meeting shall be closed for the purposes of discussing the aforementioned litigation.

**BE IT FURTHER RESOLVED**, the minutes from this meeting as they pertain to each matter shall be made available to the public as and when each matter is resolved. A more precise time frame cannot be provided at this time because it is not known, and cannot be reasonably approximated, when any of these matters will be resolved.

\_\_\_\_\_  
Terry Crowley, Jr.,  
Council President

**I HEREBY CERTIFY THAT** the foregoing resolution was duly adopted by the City Council of the City of Ocean City, New Jersey at a Council Meeting held on Thursday, June 11, 2026 with the voting record as indicated below.

NAME	MOTION	SECOND	AYE	NAY	ABSENT	ABSTAINED
Barnes						
Crowley						
Hartzell						
Levchuk						
Madden						
Polcini						
Winslow						

\_\_\_\_\_  
Melissa G. Rasner, City Clerk

CITY OF OCEAN CITY  
CAPE MAY COUNTY, NEW JERSEY

**RESOLUTION**

No. 26-147

**AUTHORIZING THE ADVERTISEMENT OF CITY CONTRACT #26-06, 34<sup>TH</sup> STREET  
SANDCASTLE PARK REVITALIZATION**

**BE IT RESOLVED** by the City Council of the City of Ocean City, New Jersey that it authorizes the advertisement of specifications for City Contract #26-06, 34<sup>th</sup> Street Sandcastle Park Revitalization.

---

Terry Crowley, Jr.  
Council President

Note: The legal advertisement will be tentatively placed on the Ocean City Public Notices Webpage tentatively on Friday, June 17, 2026 with the bid opening scheduled on Thursday, July 2, 2026 and an anticipated date of award on Thursday, July 16, 2026.

Files: RAU CC #26-06 34<sup>th</sup> Street Sandcastle Park Revitalization.docx

**I HEREBY CERTIFY THAT** the foregoing resolution was duly adopted by the City Council of the City of Ocean City, New Jersey at a Council Meeting held on Thursday, June 11, 2026, with the voting record as indicated below.

NAME	MOTION	SECOND	AYE	NAY	ABSENT	ABSTAINED
Barnes						
Crowley						
Hartzell						
Levchuk						
Madden						
Polcini						
Winslow						

---

Melissa G. Rasner, City Clerk

**CITY OF OCEAN CITY  
CAPE MAY COUNTY, NEW JERSEY**

**RESOLUTION**

**No. 26-148**

**AUTHORIZING THE CITY’S PARTICIPATION IN THE HOUSTON-GALVESTON  
AREA COUNCIL OF GOVERNMENTS (HGAC-BUY) CONTRACT #FS12-23, FIRE  
APPARATUS AND RELATED VEHICLES TO PURCHASE TWO ENFORCER  
PUMPERS**

**WHEREAS**, the City of Ocean City is allowed to participate in National Purchasing Cooperative per N.J.S.A. 52:34-6.2 (b) P.L. 2011, c.139 which was enacted into law permitting agencies to utilize National Purchasing Cooperatives; and

**WHEREAS**, the use of the Houston-Galveston Area Council of Governments (HGAC-Buy) Cooperative Contract #FS12-23 was advertised on Ocean City’s Public Notices Webpage on Tuesday, May 26, 2026; and

**WHEREAS**, Houston-Galveston Area Council of Governments (HGAC-Buy), as the lead agency has awarded Cooperative Contract #FS12-23, Fire Apparatus and Related Vehicles to Fire & Safety Services Ltd.; and

**WHEREAS**, Contract #FS12-23 was awarded to Fire & Safety Services Ltd., 200 Ryan Street, South Plainfield, New Jersey 07080; and

**WHEREAS**, the Fire Department has sourced quotes to purchase two (2) Enforcer Pumpers through Fire & Safety Services Ltd. a certified distributor of Pierce refuse handling equipment; and

**WHEREAS**, Houston-Galveston Area Council of Governments (HGAC-Buy) Cooperative Contract #FS12-23, Fire Apparatus and Related Vehicles with Fire & Safety Services Ltd. is currently listed to be in effect through November 20, 2027; and

**WHEREAS**, Richard V. Bickmore, Jr., Deputy Chief of Fire and Rescue Services; , Bernard F. Walker, Chief of Fire and Rescue Services; Christine D. Gundersen, Manager of Capital Planning; Thomas R. Mahar, Purchasing Assistant; and Michael Rossbach Jr., QPA, City Purchasing Manager have reviewed the contract from Houston-Galveston Area Council of Governments (HGAC-Buy) Cooperative Contract #FS12-23, Fire Apparatus and Related Vehicles and recommend an award to **Fire & Safety Services Ltd., 200 Ryan Street, South Plainfield, New Jersey 07080**, as follows:

<u>Item</u>	<u>Description</u>	<u>Total Amount</u>
1.	(2) Enforcer Pumpers.....	\$2,183,470.98
<b>Total Amount for a Two Enforcer Pumpers.....</b>		<b>\$2,183,470.98</b>

**NOW THEREFORE, BE IT RESOLVED** by the City Council of the City of Ocean City, New Jersey, authorizes the participation in the Houston-Galveston Area Council of Governments (HGAC-Buy) #FS12-23, for Two (2) Enforcer Pumpers with Fire & Safety Services Ltd., 200 Ryan Street, South Plainfield, New Jersey 07080; and

The Director of Financial Management certifies that funds are available for Calendar Year 2026 and \$2,183,470.98 shall be charged to Capital Account #C-04-55-337-410.

**CERTIFICATION OF FUNDS**

\_\_\_\_\_  
Frank Donato III, CFO  
Director of Financial Management

\_\_\_\_\_  
Terry Crowley, Jr.  
Council President

Files: RES HGAC-Buy Enforcer Pumpers.docx

**I HEREBY CERTIFY THAT** the foregoing resolution was duly adopted by the City Council of the City of Ocean City, New Jersey at a Council Meeting held on Thursday, June 11, 2026, with the voting record as indicated below.

NAME	MOTION	SECOND	AYE	NAY	ABSENT	ABSTAINED
Barnes						
Crowley						
Hartzell						
Levchuk						
Madden						
Polcini						
Winslow						

\_\_\_\_\_  
Melissa G. Rasner, City Clerk

200 RYAN STREET  
SOUTH PLAINFIELD NJ 07080  
Phone: 800-400-8017  
WWW.F-SS.COM

# FIRE & SAFETY SERVICES

FIRE, LAW ENFORCEMENT,  
& TACTICAL APPARATUS

- SALES
- SERVICE
- PARTS

May 19, 2026

City of Ocean City (NJ)

Dear Chief Walker:

Thank you for your interest in purchasing Pierce fire apparatus through the Houston-Galveston Area Council (HGAC) cooperative purchasing program. This is being issued in the name of Fire & Safety Services as prime contractor for all orders. See end of this letter for terms and conditions that are included in the proposal binder but provided here as well.

This letter serves as the quote under the HGAC Contract FS12-23. For these units we used the base model 23P-105- Enforcer Pumper 750 tank, 1500 pump 1023

Pursuant to the regulations established under the HGAC program, we modified that base model to meet your departmental requirements. Pierce is offering an HGAC quoted price of **\$2,183,470.98** for two (2) units.

**\*NOTE-** Pricing is valid through 7/30/2026

Currently this apparatus would be ready for final inspection at Pierce Mfg. in approximately 28-32 months. Due to global supply chain restraints, any delivery date contained herein is a good faith estimate as of the date of this order/contract, and merely an approximation based on current information. Delivery updates will be made available, and a final firm delivery date will be provided as soon as possible.

With the HGAC process, since the terms of the agreement have already been negotiated between the vendors and HGAC, there is no need for a separate contract, just a PO made out to Fire & Safety Services Ltd., issued by, you, the customer. Fire & Safety would then send a copy of the official HGAC pricing worksheet along with a copy of the Purchase Order to the HGAC where they would issue an order confirmation. We would also coordinate all paperwork with the manufacturer to start the order with them. We would also provide you with a copy of the official HGAC pricing worksheet for your records.

If you have any further questions, please do not hesitate to contact us directly or your area sales representative, Rick Pumphrey.

**Please see IMPORTANT terms and conditions on Page #2 of this document.**

Very truly yours,  
*David L. Russell*  
David L. Russell  
President

Main Office and Service/Parts Fax (908) 412-0513

Sales Department Fax (908) 412-0538



200 RYAN STREET  
SOUTH PLAINFIELD NJ 07080  
Phone: 800-400-8017  
WWW.F-SS.COM

# FIRE & SAFETY SERVICES

**FIRE, LAW ENFORCEMENT,  
& TACTICAL APPARATUS**

- SALES
- SERVICE
- PARTS

## TERMS AND CONDITIONS:

### FORCE MAJUERE:

Bidder shall not be responsible nor deemed to be in default on account of delays in performance due to causes which are beyond the Bidder's control, which makes the Bidder's performance impracticable, including, but not limited to civil wars, insurrections, strikes, riots, storms, floods, other acts of nature, explosions, earthquakes, accidents, any acts of government, delay in transportation, inability to obtain necessary labor supplies or manufacturing facilities, allocation regulations or orders affecting materials, equipment, facilities, or completed products, failure to obtain any required license or certificates, act of God or the public enemy or terrorism, failure of transportations, vehicle accidents during manufacturing and/or testing, and/or delivery, epidemics, quarantine restrictions, failure of vendors (due to causes similar to those within the scope of this clause) to perform their contracts or labor troubles causing cessation, slowdown, or interruptions of work

### TRADE-IN (IF APPLICABLE):

The apparatus being traded shall conform to the following requirements (no exception):

- 1) The unit(s) is roadworthy at time of sale and has no hidden defects that are known to the Purchasing Authority or the Fire Department and not disclosed that would make the unit unfit for service.
- 2) The unit is not advertised for sale in any manner or fashion, by any means, or offered for sale to any other parties, either wholesale or retail. In the event that this unit is listed, marketed, advertised or displayed to a used fire apparatus broker, dealer, or firm involved in the sale of used fire apparatus; this offer shall immediately become null and void.
- 3) All of the basic and affixed equipment is included as specified on the sheet sent to us at time of sale. This includes warning lights and sirens (electronic and/or mechanical) and any other basic equipment provided by the Purchasing Authority or Fire Department.
- 4) The fire pump will pass a certified pump test in accordance with NFPA Standard 1911 to its original rated capacity and the booster tank does not leak at time of sale. The aerial ladder, if so equipped, shall pass an aerial certification in accordance with NFPA Standard 1914 at time of sale. **NOTE: A current (within 30/60 days prior to release date) certification MUST BE PROVIDED to the dealer and/or its approved vendor at time of transfer (NO EXCEPTION).** Time of Sale is defined as the actual date the transfer of the vehicle occurs from the Purchasing Authority and/or Fire Department to the buyer. **The Purchasing Authority and/or Fire Department are solely responsible for the costs of any and all repairs to ensure that the terms of this paragraph are met.**
- 5) A unit with a light tower must have the light tower fully functional at time of transfer unless otherwise agreed upon at the time of quotation of trade-in price.
- 6) The apparatus tires shall not be more than 7 years old and shall have a minimum tread depth of 4/32 on steering axles and 2/32 on non-steering axles with no punctures, cuts to the cord, bulges or sidewall separation. This is in compliance with the requirements of the FMVSS and NFPA guidelines.
- 7) The apparatus shall be made available to Fire & Safety Services, Ltd. and/or its approved vendor at the time of delivery of the new apparatus. In no case shall the trade-in be left at the fire station for more than 14-days after delivery of the new apparatus. Once the new apparatus has been delivered the trade-in is now property of Fire & Safety Services, Ltd. and/or its vendor. Any damages occurring to this apparatus during this period shall be responsibility of the Purchasing Authority and/or Fire Department that is utilizing the vehicle during this time frame.

Failure to comply with any of these provisions will result in a reduction of the trade-in allowance commiserate to the cost to correct such deficiencies. Purchasing Authority will be solely responsible for making up any difference between trade-in quote allowance and deductions in this circumstance.

### PERSISTENT INFLATIONARY ENVIROMENT:

If the Producer Price Index of Components for Manufacturing [[www.bls.gov](http://www.bls.gov) Series ID: WPUID6112] ("PPI") has increased at a compounded annual growth rate of 5.0% or more between the month Pierce accepts our order ("Order Month") and a month 14 months prior to the then predicted Ready For Pickup date ("Evaluation Month"), then pricing may be updated in an amount equal to the increase in PPI over 5.0% for each year or fractional year between the Order Month and the Evaluation Month.

The seller will document any such updated price for the customer's approval before proceeding and provide an option to cancel the order the order pursuant to the cancellation provisions below if the updated price isn't accepted.

### CANCELLATION/TERMINATION:

In the event Customer and Fire & Safety Services, Ltd. enter into a Purchase Agreement and the Customer thereafter cancels, or terminates the Purchase Agreement; Fire & Safety Services, Ltd. will charge a cancellation fee as follows: a) 10% of Purchase Price after order is accepted and entered by Fire & Safety Services, Ltd; b) 20% of Purchase Price after completion of the pre-construction phase of order process and prints are reviewed and executed; c) 50% of Purchase Price after the requisition of any materials or commencement of any manufacturing or assembly of the product by either Fire & Safety Services, Ltd, or the manufacturer of the product. The tier of cancellation fee applicable to any cancellation shall be in the sole and absolute discretion of Fire & Safety Services, Ltd.

### WARRANTIES:

Fire & Safety Services Ltd. makes no warranties express, implied, or otherwise of ANY KIND. The only warranties applicable to the vehicle are those provided by the Manufacturer of the Product and/or the component manufacturers as provided in the proposal binder and at time of delivery.

### TITLE AND REGISTRATION:

Due to regulations covering Municipal and emergency vehicles, titling and registration of the vehicle are solely the responsibility of the Purchasing Authority and/or the Fire Department. Fire & Safety Services, Ltd. is NOT responsible for the titling or registration of the vehicle but will assist in any manner necessary.

### PAYMENT:

Payment of the apparatus is due at time of delivery. If an early payment, in whole or in part, has been made, that payment along with any applicable credit for the payment will be reflected in the final invoice which will be provided at least two (2) weeks prior to estimated delivery. If tool/equipment mounting is part of the sale of the apparatus the mounting of said equipment will not delay the delivery or payment of the apparatus. Should the customer wish, they may withhold the amount quoted for tool mounting until such time as it is completed, but the apparatus will be paid for when all prep work is completed.

Main Office and Service/Parts Fax (908) 412-0513

Sales Department Fax (908) 412-0538





**CONTRACT PRICING WORKSHEET**  
For MOTOR VEHICLES Only

Contract No.:

FS12-23

Date Prepared:

5/19/2026

Due to global supply chain constraints, any delivery date contained herein is a good faith estimate as of the date of this order/contract. As needed, delivery updates will be provided as soon as possible.

Buying Agency:	City of Ocean City (NJ) Bid#395	Contractor:	Fire & Safety Services Ltd
Contact Person:	Michael Rossbach Jr- QPA	Prepared By:	Robert Emery
Phone:	609-525-9283	Phone:	800-400-8017
Fax:		Fax:	908-412-0513
Email:	<a href="mailto:mrossbachjr@ocnj.us">mrossbachjr@ocnj.us</a>	Email:	<a href="mailto:remery@f-ss.com">remery@f-ss.com</a>

Product Description	23P-105	May 2026 Pricing	Enforcer Pumper 750 tank, 1500 pump 1023
---------------------	---------	------------------	--

**A. Product Item Base Unit Price Per Contractor's H-GAC Contract:** \$981,306.00

**B. Published Options - Itemize below - Attach additional sheet(s) if necessary.**

(Note: Published Options are "manufacturer standard options" which were submitted and priced in Contractor's proposal.)

Description	Cost	Description	Cost
Subtotal From Additional Sheet(s):			
Subtotal B:			\$151,761.00

**C. Customization Category Totals - Itemize below / Attach additional sheet(s) if necessary.**

(Note: Customization options are "manufacturer non-standard options" which were submitted and priced in Contractor's proposal.)

Description	Cost	Description	Cost
Dealer to Pay HGAC Fee	-\$2,000.00		
Discount for two (2) Truck Order			
Subtotal From Additional Sheet(s):			
Subtotal C:			-\$2,000.00

Check: Total cost of Customization Categories (C) cannot exceed 25% of the total of the Base Unit Price plus Published Options (A+B).	For this transaction the percentage is:	0%
---	---	----

**D. Total Cost Before Any Applicable Trade-In / Other Allowances / Discounts (A+B+C)**

Quantity Ordered:	2	X Subtotal of A + B + C:	\$1,131,067.00	=	Subtotal D:	\$2,262,134.00
-------------------	---	--------------------------	----------------	---	-------------	----------------

**E. H-GAC Order Processing Charge (Amount Per Current Policy)** Subtotal E: \$2,000.00

**F. Trade-Ins / Special Discounts / Other Allowances / Freight / Installation / Miscellaneous Charges**

Description	Cost	Description	Cost
Dealer to Pay HGAC Fee	-\$2,000.00		
Discount for two (2) truck order	-\$78,663.02		
Subtotal F:			-\$80,663.02

**Delivery Date:** 28-32 Months from PO **G. Total Purchase Price (D+E+F):** \$2,183,470.98

**CITY OF OCEAN CITY  
CAPE MAY COUNTY, NEW JERSEY**

**RESOLUTION**

**No. 26-149**

**AUTHORIZING THE CITY'S PARTICIPATION IN THE HOUSTON-GALVESTON  
AREA COUNCIL OF GOVERNMENTS (HGAC-BUY) CONTRACT #RH04-25 ,  
REFUSE HANDLING EQUIPMENT TO PURCHASE ONE (1) PAC MAC RL8 8 CUBIC  
YARD REAR LOADER TRASH TRUCK**

**WHEREAS**, the City of Ocean City is allowed to participate in National Purchasing Cooperative per N.J.S.A. 52:34-6.2 (b) P.L. 2011, c.139 which was enacted into law permitting agencies to utilize National Purchasing Cooperatives; and

**WHEREAS**, the use of the Houston-Galveston Area Council of Governments (HGAC-Buy) Cooperative Contract #RH04-25 was advertised on Ocean City's Public Notices Webpage on Monday, June 1, 2026; and

**WHEREAS**, Houston-Galveston Area Council of Governments (HGAC-Buy), as the lead agency has awarded Cooperative Contract #RH04-25, to Hol-Mac Corporation; and

**WHEREAS**, the Department of Public Works has sourced quotes to purchase one (1) Pac-Mac Trash Truck through Mid-Atlantic Waste Systems a certified distributor of Hol-Mac Corporation refuse handling equipment; and

**WHEREAS**, Houston-Galveston Area Council of Governments (HGAC-Buy) Cooperative Contract #RH04-25, Hol-Mac Corporation is currently listed to be in effect through March 3, 2029; and

**WHEREAS**, Michael Rossbach, Sr., Director of Public Works; Christine D. Gundersen, Manager of Capital Planning; Thomas R. Mahar, Purchasing Assistant; and Michael Rossbach Jr., QPA, City Purchasing Manager have reviewed the contract from Houston-Galveston Area Council of Governments (HGAC-Buy) Cooperative Contract #RH04-25, Refuse Handling Equipment and recommend an award to **Mid-Atlantic Waste Systems, 10641, Cordova Road, Easton MD 21601**, as follows:

<u>Item</u>	<u>Description</u>	<u>Total Amount</u>
1.	Pac-Mac RL8 8 Cubic Yard Real Loader Trash Truck.....	\$147,065.00
<b>Total Amount for one (1) Pac-Mac Trash Truck.....</b>		<b>\$147,065.00</b>

**NOW THEREFORE, BE IT RESOLVED** by the City Council of the City of Ocean City, New Jersey, authorizes the participation in the Houston-Galveston Area Council of Governments (HGAC-Buy) #RH04-25, Pac-Mac Trash Truck with Mid-Atlantic Waste Systems, 10641, Cordova Road, Easton MD 21601; and

The Director of Financial Management certifies that funds are available for Calendar Year 2026 and \$147,073.00 shall be charged to Capital Account #C-04-55-337-417.

**CERTIFICATION OF FUNDS**

\_\_\_\_\_  
Frank Donato III, CFO  
Director of Financial Management

\_\_\_\_\_  
Terry Crowley, Jr.  
Council President

Files: RES HGAC-Buy Pac Mac Trash Truck.docx

**I HEREBY CERTIFY THAT** the foregoing resolution was duly adopted by the City Council of the City of Ocean City, New Jersey at a Council Meeting held on Thursday, June 11, 2026, with the voting record as indicated below.

NAME	MOTION	SECOND	AYE	NAY	ABSENT	ABSTAINED
Barnes						
Crowley						
Hartzell						
Levchuk						
Madden						
Polcini						
Winslow						

\_\_\_\_\_  
Melissa G. Rasner, City Clerk



# CITY OF OCEAN CITY

AMERICA'S GREATEST FAMILY RESORT

OPERATIONS and ENGINEERING DEPARTMENT

---

## Memo

**To:** Michael Rossbach Jr., Purchasing Agent  
**From:** Michael Rossbach, Public Works  
**CC:** George Savastano, Frank Donato, Christine Gundersen  
**Date:** June 1, 2026  
**Re:** Rear Loading Trash Truck

---

Ocean City Public Works is requesting support to purchase an eight-yard rear loading trash truck from Mid-Atlantic Waste Systems. The purchase of this truck will be through the HGAC Buy cooperative and is supported by the 2026 Capital Plan.

The requested truck will be a small conventional rear loading trash truck with an eight (8) yard compacting body. As a rear loader, workers will be able to empty trash and recycle cans without lifting cans over their heads as they do now. This should limit soft tissue injuries and workman's compensation claims. The load capacity of the requested truck is larger than the trucks currently servicing the boardwalk allowing for servicing all the cans on the boardwalk in one run. Even with the larger capacity, the truck is under the load rating of the rebuilt boardwalk. The chassis of the truck has a "cab over" lay out offering excellent frontal visibility and a rear facing camera for added safety. The packing mechanism can be used without revving the engine making for a quieter run early in the morning. The plan is to phase out the "Wayne Pup" trash trucks, currently in use, ultimately selling them on GovDeals.

If you have any questions or need more supporting information, please don't hesitate to contact me.

115 12<sup>TH</sup> STREET, OCEAN CITY, NJ 08226-3642  
609-399-6111 Fax:609-399-8407  
[www.ocnj.us](http://www.ocnj.us)



Division of THC Enterprises, Inc.

Easton, MD \* Baltimore, MD \* Chesapeake, VA Chester, PA \*  
Clinton, MD \* Cheswick, PA \* Salem, VA

Phone 800-338-7274 Fax 410-820-9916

Visit us on the web! [www.mawaste.com](http://www.mawaste.com)



# PROPOSAL

Remittance Address for Deposits:

10641 Cordova Road  
Easton, MD 21601

**SOLD TO**  
Michael Rossbach  
OCEAN CITY, CITY OF  
115 12th St  
Ocean City, NJ 8226

**END USER / SHIP TO**  
Michael Rossbach  
OCEAN CITY, CITY OF  
115 12th St  
Ocean City, NJ 8226

Quote #: RSSQ44422  
Account:  
Terms:  
Date: 04/15/26

+1 609-399-6111  
mrossbach@ocnj.us

+1 609-399-6111  
mrossbach@ocnj.us

Sales Rep Jack Lane

Quote expires 30 days from proposal date. Due to fluctuating materials and fuel charges, final price can change without notice. We appreciate the opportunity to work with you on this!

QTY	DESCRIPTION	UNIT PRICE	EXT PRICE
<i>Hol-Mac HGAC Contract #RH04-25</i>			
1.00	Pac Mac RL8 8 Cubic Yard Rear Loader Emergency stop on curb side Driver alert buttons on both sides Hot Shift PTO Standard Controls Paint: White LED Lighting Dual Amber Oval LED Strobe, Rear	\$63,574.00	\$63,574.00
1.00	Mounted On: 2026 Isuzu NRR GVW: 19,500 VIN: White	\$66,788.00	\$66,788.00
1.00	Hyper Hopper Extended Sill	\$989.00	\$989.00
1.00	LED Hopper Work Lights	\$644.00	\$644.00
1.00	7" Rear Vison Camera	\$2,678.00	\$2,678.00
1.00	Shovel and Broom Holder Curbside Tailgate	\$450.00	\$450.00
1.00	Dual Amber Strobes Front	\$378.00	\$378.00
1.00	Additional Strobe Package	\$994.00	\$994.00
1.00	Single Cascade Rotary Actuated Cart Tipper	\$7,330.00	\$7,330.00
1.00	Freight	\$3,000.00	\$3,000.00
1.00	PacMac Mini Rear Loader MAWS PDI	\$240.00	\$240.00

*Terms:*

*Delivery: In Stock Pending Prior Sale*

*All built per manufacturer's standard specifications.*

*No title or tag fees included.*

*Due to the volatility of the fuel and steel markets, prices are subject to change without notice.*

*Price does not include any local, state, or federal excise tax.*

QTY	DESCRIPTION	UNIT PRICE	EXT PRICE
-----	-------------	------------	-----------

Quote expires 30 days from proposal date. Due to fluctuating materials and fuel charges, final price can change without notice. We appreciate the opportunity to work with you on this!

Subtotal	\$147,065.00
Federal Excise Tax	\$0.00
Sales Tax	\$0.00
TOTAL*	\$147,065.00

For orders under \$5,000 you may pay by credit card. Please visit [www.mawaste.com](http://www.mawaste.com) and select "Pay Bill"  
 \*Terms and limitations apply, see Payment terms below

\*Total does not include optional items

***F.E.T will be charged on all applicable items unless current F.E.T Exemption form is on file.***

*Any cancellation or modification of order will result in a 20% restocking charge to Buyer.*

**CITY OF OCEAN CITY  
CAPE MAY COUNTY, NEW JERSEY**

**RESOLUTION**

**No. 26-150**

**AUTHORIZING THE AWARD OF A PROFESSIONAL SERVICES CONTRACT TO  
ACT ENGINEERS, INC. FOR PROFESSIONAL GEOSPATIAL SERVICES FOR A  
WATERSHED INVENTORY REPORT – PHASE 1**

**WHEREAS**, the City of Ocean City requires professional geospatial services for a watershed inventory report – Phase 1 only; and

**WHEREAS**, a contract for Professional Services with ACT Engineers, Inc. may be entered into without competitive bidding pursuant to N.J.S.A. 40A:11-5(1)(a)(i) & N.J.S.A. 19:44A-20.5; and

**WHEREAS**, ACT Engineers, Inc. has completed and submitted a Business Entity Disclosure Certification which certifies that neither ACT Engineers, Inc. nor any member thereof has made any contribution to a political or candidate committee for an elected office in the City of Ocean City, NJ in the previous one (1) year period, and that the contract will prohibit the said parties from making any contributions through the term of the contract; and

**WHEREAS**, ACT Engineers, Inc. has been advised that this award does not guarantee that the services described will be required during the contract period and are subject to the actual need as established by the City of Ocean City. As services are required, the City Purchasing Manager shall issue Purchase Orders for those services. No services shall be performed for the City without first obtaining a Purchase Order for said services; and

**WHEREAS**, George J. Savastano, Business Administrator; Vincent S. Bekier, Director of Capital Programs, Project Management & Engineering; Christine D. Gundersen, Manager of Capital Planning; Thomas R. Mahar, Purchasing Assistant and Michael Rossbach Jr., QPA, City Purchasing Manager have reviewed the terms and conditions of the contract and recommend award of a professional service contract to ACT Engineers, Inc. for professional geospatial services for a watershed inventory report – Phase 1 only; and

**WHEREAS**, this contract is awarded through an alternative non-advertised process, pursuant to N.J.S.A. 19:44A-20.4 et seq.; and

**NOW THEREFORE, BE IT RESOLVED** by the City Council of the City of Ocean City, New Jersey that it does hereby award a professional services contract to **ACT Engineers, Inc., 1 Washington Boulevard, Suite 3, Robbinsville, NJ 08691** for preparation and submittal professional geospatial services for a watershed inventory report – Phase 1 only:

<u>Item</u>	<u>Description</u>	<u>Total Amount</u>
1.	Data Collection – MS4 Infrastructure Mapping.....	\$13,350.00
2.	Data Gathering – NJ-WET/Interconnections/Private Stormwater.....	\$13,350.00
3.	Data Analysis – Drainage Areas.....	\$5,140.00
4.	Project Management and Coordination.....	\$5,140.00
5.	Reimbursable Expenses.....	\$1,000.00
<b>Total Amount for Items 1-5.....</b>		<b>\$37,980.00</b>

4. A copy of the Pay-to-Play Certification and the Business Registration Certificate (BRC) will be on file with the Purchasing Division.
5. A copy of this Resolution and Contract shall be available for inspection in the Ocean City Clerk's Office and shall be published on one (1) occasion in the Ocean City Sentinel.
6. The term of this contract shall be for one (1) year beginning on the date of adoption hereof or upon the completion of the prescribed work.

**CITY OF OCEAN CITY  
CAPE MAY COUNTY, NEW JERSEY**

**RESOLUTION**

**No. 26-150**

**BE IT FURTHER RESOLVED** by the City Council of the City of Ocean City that the Purchasing Manager is hereby authorized to execute a purchase order with ACT Engineers, Inc., 1 Washington Boulevard, Suite 3, Robbinsville, NJ 08691 in accordance with this resolution.

The Director of Financial Management certifies that funds are available and shall be charged to Capital Account #C-04-55-327-201.

**CERTIFICATION OF FUNDS**

\_\_\_\_\_  
Frank Donato III, CFO  
Director of Financial Management

\_\_\_\_\_  
Terry Crowley, Jr.  
Council President

Files: RPS Geospatial Services ACT.docx

**I HEREBY CERTIFY THAT** the foregoing resolution was duly adopted by the City Council of the City of Ocean City, New Jersey at a Council Meeting held on Thursday, June 11, 2026, with the voting record as indicated below.

NAME	MOTION	SECOND	AYE	NAY	ABSENT	ABSTAINED
Barnes						
Crowley						
Hartzell						
Levchuk						
Madden						
Polcini						
Winslow						

\_\_\_\_\_  
Melissa G. Rasner, City Clerk



# CITY OF OCEAN CITY

AMERICA'S GREATEST FAMILY RESORT

DEPARTMENT OF OPERATIONS AND ENGINEERING

---

## Memo

**To:** Michael Rossbach Jr.  
**From:** Michael Rossbach, Director of Public Works  
**Cc:** George Savastano, Frank Donato, Thomas Mahar  
**Date:** May 26, 2026  
**Re:** Act Engineering for Watershed Improvement Plan

---

With the additional Storm Water requirements from the State of New Jersey, Ocean City is required to develop a "Watershed Improvement Plan" (WIP). Several engineering firms with experience in developing phase one of the WIP plan were contacted with two providing quotes. Two quotes were obtained with ACT engineering being the lowest. I recommend the work be given to Act Engineering. This work is partially funded by a state grant.

If you have any questions or need more supporting information, please don't hesitate to contact me.

115 12<sup>TH</sup> STREET, OCEAN CITY, NJ 08226-3642  
609-399-6111 Fax:609-399-8407  
[www.ocnj.us](http://www.ocnj.us)



1 Washington Boulevard, Suite 3  
Robbinsville, New Jersey 08691

320 S. Shore Road, Suite D  
Marmora, New Jersey 08223  
Telephone No. (609) 918-0200  
[www.actengineers.com](http://www.actengineers.com)

VIA ELECTRONIC DELIVERY ONLY - [JSantoro@OCNJ.US](mailto:JSantoro@OCNJ.US)

May 22, 2026

Jason Santoro  
City of Ocean City  
861 Asbury Avenue  
Ocean City, New Jersey 08226  
[JSantoro@OCNJ.US](mailto:JSantoro@OCNJ.US)

**RE: Professional Geospatial Services  
Watershed Inventory Report - Phase 1 Only  
Ocean City, Cape May County, New Jersey  
ACT NO. P26054**

Dear Mr. Santoro:

Thank you for the opportunity to provide this proposal for Geospatial Services in Ocean City, Cape May County, New Jersey. In response to your request and, as discussed with Ms. Junetta Dix of our office, it is our understanding that Geospatial Support Services are needed for the preparation and submittal of the Phase 1 Watershed Inventory Report, which was due by January 1, 2026. Subsequent Phases of the required reporting will also be coming due in the near future; January 1, 2027, for Phase 2 (Watershed Assessment Report) and December 1, 2027, for Phase 3 (Watershed Improvement Plan Report).

The survey limits and project scope for the Phase 1 are based upon the 2 documents referenced below provided to ACT Engineers on February 3, 2026.

- 1 "Phase-1-watershed-inventory-report-template (1)" docx file, Page 5.
- 2 "MS4 WIP" pdf file.

ACT Engineers, Inc. (ACT) is pleased to provide this proposal for the preparation and submittal of a Phase 1 Watershed Inventory Report for the City of Ocean City.

The following scope of work is proposed:

**SCOPE OF SERVICES**

**GEOSPATIAL SERVICES**

***TASK 1 - DATA COLLECTION - MS4 INFRASTRUCTURE MAPPING***

ACT will perform the necessary research and field work to produce the required MS4 Infrastructure MS4 mapping. MS4 requirements include outfalls, groundwater discharge points, interconnections, storm drain inlets, manholes, conveyance, pump stations, and Best Management

Practice (BMP) facilities. It is understood that significant data has already been collected and uploaded to the NJDEP MS4 portal, and new data collection will be limited to the locations of manholes, conveyance(s), and property boundaries of BMP facilities. We further understand that some of the required data may be available in the City's mapping database and it may be possible to extract and utilize. The data collected and compiled as part of this task will satisfy the following required data per Phase-1-Watershed-Inventory-Report-template, page 5.

- Item 1 - All stormwater outfalls owned/operated by the permittee
- Item 8 - All storm drain inlets owned/operated by the permittee

At the request of the City, ACT will prepare the required information and electronic data included in the Watershed Inventory Report for Items 1 and 8. Due to the unknown mapping requirements and level of work to extract/assemble the required map components, ACT has initially budgeted 60 hours to this task. It is, however, noted at this time our estimate is preliminary and final adjustments may need to be made based on project need, and reporting/data requirements. It is understood that any adjustments to the proposed budget will require written authorization by the City.

#### **TASK 2 - DATA GATHERING - NJ-WET/INTERCONNECTIONS/PRIVATE STORMWATER**

ACT will perform the necessary research and data gathering from NJDEP open data, the New Jersey Watershed Evaluation Tool (NJ-WET), the New Jersey Hydrologic Modeling Database (H&H), and local municipal knowledge. The data compiled as part of this task will satisfy the following required data per Phase-1-watershed-inventory-report-template, page 5.

- Item 3 - Receiving waterbodies of those outfalls
- Item 4 - Water quality classification of all receiving waterbody segments
- Item 5 - All stormwater interconnections from the permittee's MS4 system into another entity's storm or sanitary sewer system.
- Item 7 - All stormwater interconnections into the permittee's system from another entity's storm sewer system.
- Item 9 - Area associated with each TMDL for waters that lie within or bordering the permittee's property(s)/jurisdiction.
- Item 10 - Area associated with each water quality impairment for waters that lie within or bordering the permittee's property(s)/jurisdiction.
- Item 11 - Overburdened communities.
- Item 12 - Impervious areas.
- Item 13 - Location and ownership of all stormwater infrastructure not owned or operated by the permittee.

It is understood that items 5, 7, and 13 require submittal of electronic data in a format suitable to the NJDEP via the Stormwater Document Submittal Service using NJDEP online. At the request of the City, ACT will prepare the required information and electronic data included in the Watershed Inventory Report, Items 3, 4, 5, 7, 9, 10, 11, 12, and 13. Again, due to the unknown mapping requirements and level of work to extract/assemble the required map components, ACT has allocated 60 hours to this task; however, at this time our estimate is preliminary and final adjustments may need to be made based on project need, and reporting/data requirements. It is

understood that any adjustments to the proposed budget will require written authorization by the City.

**TASK 3 – DATA ANALYSIS – DRAINAGE AREAS**

ACT will perform the necessary research and data analysis of permittee-owned outfall drainage areas; and the drainage area for each interconnection into another entities storm or sanitary sewer using recent topographic data, ArcHydro, and/or local municipal knowledge. The data compiled as part of this task will satisfy the following required data per Phase-1-watershed-inventory-report-template, page 5.

- Item 2 - Drainage area for each permittee owned/operated outfall
- Item 6 - The drainage area for each interconnection into another entities' storm or sanitary sewer system.

It is understood that items 2 and 6 require submittal of electronic data in a format suitable to the NJDEP via the Stormwater Document Submittal Service using NJDEP online. At the request of the City, ACT will prepare the required information and electronic data included in the Watershed Inventory Report including that which relates to Items 2, and 6. As described herein, ACT has allocated 20 hours to this task; however, at this time our estimate is preliminary and final adjustments may need to be made based on project need, and reporting/data requirements.

**PROJECT MANAGEMENT SERVICES**

**TASK 4 – PROJECT COORDINATION AND CONSULTATION** - ACT will schedule and attend meetings, conferences, including virtual meetings, with the Client and others as necessary to complete the project. This task also includes reviewing and responding to emails, phone calls and conferences with the Client and others during the course of the project.

Due to the unknown number of emails and duration of these meetings and phone calls, these services ACT has allocated 20 hours to this task; however, at this time our estimate is preliminary, and final adjustments may need to be made based on project need, and reporting/data requirements.

**TASK EXP - REIMBURSABLE EXPENSES** - Reimbursable expenses (printing, mileage, postage, etc.) will be invoiced in accordance with our fee schedule. A budget amount has been provided for these services.

LUMP SUM TASKS		FEE
SURVEYING SERVICES		
1	Data Collection – MS4 Infrastructure Mapping	\$13,350
2	Data Gathering – NJ-WET/Interconnections/Private Stormwater	\$13,350
3	Data Analysis – Drainage Areas	\$5,140

PROJECT MANAGEMENT SERVICES		
4	Project Management and Coordination	\$5,140
EXP	Reimbursable Expenses (Budget)	\$1,000
<b>TOTAL ESTIMATED FEE</b>		<b>\$37,980</b>

**EXCLUSIONS**

The following services are specifically **excluded** from this proposal. A separate proposal would be provided for these services if it is determined that they are required by the client. Any services not explicitly described in this proposal are beyond the scope of work and proposed budget.

**EXCLUSIONS REGARDING SCOPE OF WORK**

- Phase 2 and 3 of the Watershed Improvement Plan
- Any service not specifically described above
- Work beyond the subject property
- Additional site visits due to access issues
- Construction related engineering and/or surveying services

**TERMS AND CONDITIONS**

This proposal represents our best good faith estimate for the proposed scope of work based on the information provided by the Client at this time. Actual field conditions may be different than those anticipated herein. The fees listed in this proposal are valid for 60 days from the date of the proposal. This project will be billed monthly for the work performed. Payment of the invoice is expected within 30 days of receipt; work may cease if payment is not received within 30 days.

ACT Engineers, Inc. has attempted to include all work necessary to complete the work for your project. Any work not specifically mentioned above shall be considered extra work and will be completed upon acceptance of a separate written proposal. This proposal is, in no way, conditional upon any regulatory agency approval. Payment of services is required regardless.

If this proposal and the *terms of payment* are acceptable, please sign below and initial each page of above proposal, the attached Standard Terms and Conditions, and rate sheet, return a copy (via email is acceptable), to this office, at your earliest convenience. Work will begin when ACT Engineers, Inc. receives the signed and initialed proposal.

Thank you for this opportunity to submit this proposal. Please do not hesitate to contact this office should you have any questions or require additional information.

Sincerely,

***Brad Smith***

Brad Smith  
Director, Geospatial Services

Proposal P26054 Accepted By:
_____
Signature
_____
Date
_____
Printed Name / Title

**ACT ENGINEERS, INC.  
STANDARD TERMS AND CONDITIONS**

These terms and conditions have been attached to a written proposal (the "Proposal") dated May 22, 2026, submitted by ACT Engineers ("ACT") to Ocean City for services described as Geospatial Services (the "Services").

The Proposal sets forth certain services to be undertaken by ACT for the Client. The term "Agreement" shall mean these Standard Terms and Conditions and the Proposal collectively. The Agreement, if executed by both parties, will serve as a Contract for the proposed professional services.

**1. PERFORMANCE OF SERVICES**

ACT agrees to perform the Services as set forth in the Proposal, subject to any Unexpected Contingency (as defined in Section 8b below). The Services shall not be changed without the written agreement of both ACT and the Client, except changes that are covered in the Proposal.

The Proposal, if not accepted and executed as an Agreement, is valid for a period of sixty (60) days, after which ACT reserves the right to revise or withdraw it.

Work outside of the Agreement shall be done as extra work.

**2. PAYMENT**

The Client agrees to pay ACT for work performed in accordance with the terms of this Agreement, without regard to the success of the project or the receipt of any required permit/approval. Payment to ACT is expressly not conditioned upon the undersigned receiving any payment from third parties who are not a party to this Agreement.

- a) Any agreed upon changes to the Services requiring additional services shall be paid in

accordance with the attached compensation schedule or a mutually agreed upon lump sum.

ACT shall have the right to request payment to date of all invoices for services rendered prior to transmittal of the documents to any party. If the Client does not tender payment, ACT shall not be required to make the transmittal to any party and no liability whatsoever against ACT shall arise from this failure to transmit said documents.

Normal work hours: 8:00 A.M. to 5:00 P.M. for the office personnel, which time shall include travel portal to portal; Monday through Friday, except holidays. Should the Client require work performed outside these normal hours, the overtime rate of one half (1/2) the normal compensation rate shall be paid by the Client as an extra charge.

- b) Unless otherwise set forth in the Proposal, the Client shall be responsible for the payment of any reimbursable disbursements.

- c) ACT will send its invoices to the Client from time to time for Services rendered. The Client agrees to pay to ACT the amount shown in each invoice upon the Client's receipt of the invoice. No discount shall be allowed for prepayment.

- d) A service charge of one percent (1.0%) per month shall be added to all invoices unpaid beyond (30) days of the invoice date. In the event that any invoice is not paid within sixty (60) days of receipt, ACT shall be entitled to cease work until said invoice is paid in full or terminate its obligation under this Agreement at ACT's option.

**3. INDEPENDENT CONTRACTOR STATUS**

ACT and the Client agree that ACT is an independent contractor and not a partner, employee, or agent of the Client.

**4. SCOPE OF OPINIONS AND USE OF ACT'S DOCUMENTS**

All information, documents, or opinions given to the Client by ACT shall be for the Client's sole use in connection with specific project for which ACT was engaged by the Client.

**5. RECOMMENDATION OF ADDITIONAL SERVICES**

ACT reserves the right to recommend to the Client, in ACT's professional judgment, additional services beyond the Services set forth in the Proposal. If the Client decides that additional services should not be performed, then ACT, at its option, shall be entitled to discontinue performing any further Services for the Client if ACT believes that its exercise of professional judgment or its reputation would be impaired thereby. Upon any such discontinuance, the Client shall pay ACT for the Services performed to that date.

**6. COOPERATION**

The Client agrees to cooperate fully with ACT, and the Client agrees to give ACT prompt written notice whenever the Client becomes aware of any development that affects the scope or timing of ACT's services or any defect, error, or omission in ACT's work.

**7. CONFIDENTIAL INFORMATION: DISCLOSURE**

If ACT, in its professional judgment believes that a condition exists that poses a significant imminent danger to human health or the environment, ACT shall be entitled to disclose the same to the proper authorities; provided that ACT shall first notify the Client of that condition.

ACT shall be deemed the author of any documents prepared by ACT and shall retain common law and statutory copyright protection. ACT's documents shall not be reused by the Client or others on other projects except by agreement in writing.

**8. UNEXPECTED CONTINGENCIES**

a) If ACT's performance of any term of the Agreement is prevented, delayed, made impossible, or otherwise interfered with by any Unexpected Contingency, then ACT's performance shall be suspended during the continuance of that event and for a reasonable time thereafter.

b) For purposes of the Agreement, an "Unexpected Contingency" shall mean any event, act, omission, condition, or cause beyond ACT's reasonable control.

**9. WARRANTY**

ACT warrants to the Client that: ACT will exercise reasonable care, skill, competence, and judgment consistent with local professional standards in performing the Services set forth in the Proposal. ACT will state opinions and conclusions in accordance with all known local, county, state and other applicable regulations or ordinances, but cannot guarantee the passage or approval of any permit application or plan. In consideration of ACT's extension of the warranty to the Client, the Client agrees that THE WARRANTY IS A PART OF THE BASIS OF THE SUBJECT BARGAIN AND SHALL BE EXCLUSIVE OF ALL OTHER WARRANTIES, WHETHER EXPRESSED OR IMPLIED.

**10. DAMAGES AND PROFESSIONAL LIABILITY INSURANCE**

The Client agrees that ACT's sole liability for any breach of its warranty, or as the result of any cause of action, shall, in the aggregate, be limited to an amount equal to the lesser of:

- a) the damages suffered by the Client as the direct result thereof, or
- b) the total amount, theretofore, paid by the Client to ACT for the Services which amount shall not exceed \$25,000.

In no event shall ACT be responsible for any incidental or consequential damages.

**11. INDEMNITY**

Except to the extent of ACT's obligations under Section 10 above, the Client shall defend, indemnify and hold harmless ACT from and against any and all claims arising out of the performance of the Services.

**12. SUSPENSION OR TERMINATION OF AGREEMENT AND TERMINATION EXPENSES**

Should the project be suspended by the Client for more than thirty (30) consecutive days, ACT's compensation shall be equitably adjusted.

In the event of a termination, not the fault of ACT, ACT shall be compensated for services performed prior to termination, together with any reimbursable expenses then due and all termination expenses.

**13. ENVIRONMENTAL IMPAIRMENT**

It is agreed that the Client shall indemnify and hold harmless ACT and their consultants, agents, and employees from and against all claims related to hazardous waste.

**14. MISCELLANEOUS**

- a) Severability. If any term, condition, or provision of the Agreement shall hold invalid or unenforceable, then the remainder of this Agreement shall not be affected.
- b) Conflicting Provisions. In the event of any conflict between any of the terms of these Standard Terms and Conditions and any of the terms of the Proposal, the terms of these Standard Terms and Conditions shall control.
- c) Controlling law. This Agreement shall be governed by the laws of the State of New Jersey.

**SCHEDULE OF HOURLY RATES AND CHARGES FOR PROFESSIONAL SERVICES  
YEAR 2026**

<u>CLASSIFICATION</u>	<u>HOURLY RATE</u>
• Principal, PIX	\$ 267
• Program Manager, PVIII	\$ 257
• Managing Professional, PVII	\$ 248
• Senior Project Professional, PVI	\$ 225
• Project Professional, PV	\$ 214
• Sr. Staff Technical Representative, PIV	\$ 202
• Staff Technical Representative, PIII	\$ 194
• Senior Technician, PII	\$ 188
• Staff Engineer, PI	\$ 179
• Senior Construction Inspector ETV	\$ 179
• Designer, ETIV	\$ 166
• Construction Inspector, ETIII	\$ 156
• Technician, ETII	\$ 133
• Administrative Support, CL	\$ 121
• Survey Crew	\$ 282
• Survey Party Chief, ETIV	\$ 173
• Survey Technician, ETIII	\$ 144
• Surveying Aide, ETI	\$ 121

Compensation for expenses and other charges shall be as follows:

Truck	\$150/day up to 100 mi then current federal rate for miles over 100
Personal vehicle mileage	Federal rate
Support Boat / 3D Scanner	\$500/day
Boat or R/C Hydro Survey Vessel	\$200/day
Rentals, Subcontractors, and Bulk Reproduction	Cost + 15%
VibeCore® Sampling Equipment	\$200/day + \$30/sample
Plot prints	\$5 per page
8.5 x 11 prints	\$0.25 per page
Per Diem rates	\$68 per day

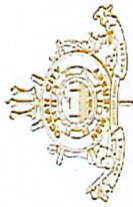

**CITY OF OCEAN CITY  
AMERICA'S GREATEST FAMILY RESORT**

**PURCHASING DIVISION**

**SUMMARY OF BID PROPOSALS**

**BY THE GOVERNING BODY OF THE CITY OF OCEAN CITY, NJ**

Date Received: 22-May-26

City Contract #:

Bid Proposal Name: Data Collection and Mapping for Watershed Improvement Plan Phase 1

Name, Address & Bid Proposal of Each Bidder		ACT Engineers 320 Shore Road Suite D Marmora, NJ 08223 609-918-0200		Remington and Vernick Engineers 4907 New Jersey Avenue Wildwood, NJ 08260 609-522-5150	
ITEM	DESCRIPTION	QTY	UNIT		
1	WIP Data Collection and Mapping			\$ 37,980.00	\$ -
2				\$ -	\$ -
				<b>TOTAL:</b>	<b>\$ 37,980.00</b>
<b>REQUIRED INFORMATION</b>					

Key:

**CITY OF OCEAN CITY  
CAPE MAY COUNTY, NEW JERSEY**

**RESOLUTION**

**No. 26-151**

**AUTHORIZING CHANGE ORDER #8 TO CITY CONTRACT #24-28, VARIOUS ALLEYS, ROADS & DRAINAGE IMPROVEMENTS, PHASE I WITH PAVING PLUS, LLC**

**WHEREAS**, the specifications were authorized for advertisement by Resolution #24-60-110 on Thursday, September 12, 2024 for City Contract #24-28, Various Alleys, Roads & Drainage Improvements, Phase I; and

**WHEREAS**, the Notice to Bidders was advertised in the Ocean City Sentinel on Wednesday, December 4, 2024 and the Invitation to Bidders was distributed to twenty-four (24) prospective bidder(s) for City Contract #24-28, Various Alleys, Roads & Drainage Improvements, Phase I; and

**WHEREAS**, the bid proposals were opened for City Contract #24-28, Various Alleys, Roads & Drainage Improvements, Phase I on Thursday, December 19, 2024 and seven (7) bid proposals were received; and

**WHEREAS**, Arthur Chew, P.E. (Arthur Chew Consulting); George J. Savastano, Business Administrator; Vincent S. Bekier, Director of Capital Programs, Project Management & Engineering; Christine D. Gundersen, Manager of Capital Planning; Thomas R. Mahar, Purchasing Assistant; Michael Rossbach, Jr., QPA, Assistant Purchasing Agent and Joseph S. Clark, Jr., QPA, City Procurement Manager have reviewed the bid proposals and the specifications and recommended that the contract be awarded to Paving Plus, LLC, P.O. Box 464, Glassboro, NJ 08028 as the lowest responsible bidder; and

**WHEREAS**, The City Council of the City of Ocean City New Jersey authorized the award of City Contract #24-28, Various Alleys, Roads & Drainage Improvements, Phase I to Paving Plus, LLC on Thursday, January 9, 2025 by Resolution #25-61-226 in the amount of \$2,094,070.00 charged to Capital Account #C-04-55-327-101; and

**WHEREAS**, the City Council of the City of Ocean City authorized Change Order #1 to City Contract #24-28, Various Alleys, Roads & Drainage Improvements on Thursday, March 13, 2025 by Resolution #25-61-312 in the decreased amount of (\$7,144.00) charged to Capital Account #C-04-55-327-101 for a revised contract total of \$2,086,926.00 an overall decrease of (\$7,144.00) or -0.34% to Purchase Order #25-00252; and

**WHEREAS**, the City Council of the City of Ocean City authorized Change Order #2 to City Contract #24-28, Various Alleys, Roads & Drainage Improvements on Thursday, April 24, 2025 by Resolution #25-61-367 in the additional amount of \$4,770.00 charged to Capital Account #C-04-55-327-101 for a revised contract total of \$2,091,696.00 an overall decrease of (\$2,374.00) or -0.11% to Purchase Order #25-00252; and

**WHEREAS**, the City Council of the City of Ocean City authorized Change Order #3 to City Contract #24-28, Various Alleys, Roads & Drainage Improvements on Thursday, April 24, 2025 by Resolution #25-61-367 in the additional amount of \$23,280.00 charged to Capital Account #C-04-55-327-101 for a revised contract total of \$2,114,976.00 an overall increase of \$20,906.00 or 1.00% to Purchase Order #25-00252; and

**WHEREAS**, the City Council of the City of Ocean City authorized Change Order #4 to City Contract #24-28, Various Alleys, Roads & Drainage Improvements on Thursday, May 22, 2025 by Resolution #25-62-396 in the reduced amount of (\$10,980.00) charged to Capital Account #C-04-55-327-101 for a revised contract total of \$2,103,996.00 an overall increase of \$9,926.00 or 0.47% to Purchase Order #25-00252; and

**WHEREAS**, the City Council of the City of Ocean City authorized Change Order #5 to City Contract #24-28, Various Alleys, Roads & Drainage Improvements on Thursday, June 12, 2025 by Resolution #25-62-403 in the reduced amount of (\$38,910.00) charged to Capital Account #C-04-55-327-101 for a revised contract total of \$2,065,086.00 an overall decrease of (\$28,984.00) or -1.36% to Purchase Order #25-00252; and

**CITY OF OCEAN CITY  
CAPE MAY COUNTY, NEW JERSEY**

**RESOLUTION**

**No. 26-151**

**WHEREAS**, the City Council of the City of Ocean City authorized Change Order #6 to City Contract #24-28, Various Alleys, Roads & Drainage Improvements on Thursday, July 17, 2025 by Resolution #25-62-441 in the increased amount of \$25,970.75 charged to Capital Account #C-04-55-327-101 for a revised contract total of \$2,091,056.75 an overall decrease of (\$3,013.25) or -0.14% to Purchase Order #25-00252; and

**WHEREAS**, the City Council of the City of Ocean City authorized Change Order #7 to City Contract #24-28, Various Alleys, Roads & Drainage Improvements on Thursday, September 25, 2025 by Resolution #25-62-492 in the increased amount of \$65,315.00 charged to Capital Account #C-04-55-327-101 for a revised contract total of \$2,156,371.75, an overall increase of \$18,621.75 or 0.89% to Purchase Order #25-00252; and

**WHEREAS**, the City of Ocean City has identified an increase in the number of materials and items required to complete the project; and

**WHEREAS**, Arthur Chew, P.E. (Arthur Chew Consulting); George J. Savastano, Business Administrator; Vincent S. Bekier, Director of Capital Programs, Project Management & Engineering; Christine D. Gundersen, Manager of Capital Planning; Thomas R. Mahar, Purchasing Assistant and Michael Rossbach, Jr., QPA, City Purchasing Manager have reviewed and certified Change Order #8 to City Contract #24-28, Various Alleys, Roads & Drainage Improvements, Phase I as follows:

**Paving Plus, LLC  
P.O. Box 464  
Glassboro, NJ 08028**

**Supplemental Items (Change Order #8)**

<u>Item</u>	<u>Description</u>	<u>Quantity</u>	<u>Unit Price</u>	<u>Amount</u>
S-2	Installation of Pipe at 20 <sup>th</sup> Street.....	1 L.S.	\$13,200.00	\$13,200.00
<b>Total Amount for Change Order #8.....</b>				<b>\$13,200.00</b>

**WHEREAS**, the newly adjusted contract cost including Change Order #8 is \$2,169,571.75, a total increase of \$75,501.75 or 3.61% to Purchase Order #25-00252 for City Contract #24-28, Various Alleys, Roads & Drainage Improvements, Phase I; and

**NOW THEREFORE, BE IT RESOLVED** by the City Council of the City of Ocean City, New Jersey that it authorizes Change Order #8 to Purchase Order #25-00252 for City Contract #24-28, Various Alleys, Roads & Drainage Improvements, Phase I; and

CITY OF OCEAN CITY  
CAPE MAY COUNTY, NEW JERSEY

**RESOLUTION**

No. 26-151

**BE IT FURTHER RESOLVED** that the Director of Financial Management is authorized to process Change Order #8 in the increased amount of \$13,200.00 to Purchase Order #25-00252 for City Contract #24-28, Various Alleys, Roads & Drainage Improvements, Phase I to be charged to the following Capital Account #C-04-55-327-101.

**CERTIFICATION OF FUNDS**

\_\_\_\_\_  
Frank Donato III, CFO  
Director of Financial Management

\_\_\_\_\_  
Terry Crowley, Jr.  
Council President

Files: RES CO #8 CC #24-28 Various Alleys Roads & Drainage.docx

**I HEREBY CERTIFY THAT** the foregoing resolution was duly adopted by the City Council of the City of Ocean City, New Jersey at a Council Meeting held on Thursday, June 11, 2026, with the voting record as indicated below.

NAME	MOTION	SECOND	AYE	NAY	ABSENT	ABSTAINED
Barnes						
Crowley						
Hartzell						
Levchuk						
Madden						
Polcini						
Winslow						

\_\_\_\_\_  
Melissa G. Rasner, City Clerk



CITY OF OCEAN CITY, ENGINEERING DIVISION  
 VARIOUS ALLEYS, ROADS & DRAINAGE IMPROVEMENTS, PHASE I

CHANGE ORDER NO. 8  
 FILE NO. 24-28

PURCHASE ORDER #  
 25-00252  
 RESOLUTION #  
 25-61-226

CONTRACTOR:  
 PAVING PLUS, LLC  
 P.O. BOX 464  
 GLASSBORO, NJ 08028

REASON FOR CHANGE: 5/27/2026  
 See Attached

THE TIME PROVIDED FOR COMPLETION OF THIS PROJECT IS:  
 \_\_\_ UNCHANGED, \_\_\_ INCREASED, \_\_\_ DECREASED, BY \_\_\_ CALENDAR DAYS.

UPON EXECUTION THIS DOCUMENT SHALL BECOME AN AMENDMENT TO THE CONTRACT.

TYPE OF CHANGE	ITEM #	DESCRIPTION	QTY	UNITS	UNIT PRICE	AMOUNT
SUPPLEMENTAL	S-2	Pipe at 20th Street	1	Lump Sum	\$13,200.00	\$13,200.00
					<b>SUBTOTAL:</b>	\$13,200.00
EXTRA	0			#N/A	\$0.00	
					<b>SUBTOTAL:</b>	\$0.00
REDUCTION	0			#N/A	\$0.00	
					<b>SUBTOTAL:</b>	\$0.00

CHANGE ORDER SUMMARY

PREVIOUS CHANGE ORDERS			CURRENT CHANGE ORDER	
NO.	AMOUNT	REASON FOR CHANGE	TYPE OF CHANGE	TOTAL
1	(\$7,144.00)	See Attached		
2	\$4,770.00	See Attached Memo	+ SUPPLEMENTAL	\$13,200.00
3	\$23,280.00	See Attached Memo		
4	(\$10,980.00)	See Attached Proposal	+ EXTRA	\$0.00
5	(\$38,910.00)	See Attached Proposal		
6	\$25,970.75	See Attached Proposal	- REDUCTIONS	\$0.00
7	\$65,315.00	See Attached Memo		
8	\$13,200.00	See Attached	NET CONTRACT CHANGE	
9			THIS CHANGE ORDER	\$13,200.00
10				

ORIGINAL CONTRACT AMOUNT	\$2,094,070.00
AMENDED CONTRACT AMOUNT	\$2,169,571.75
TOTAL CONTRACT CHANGE (AMOUNT)	\$75,501.75
TOTAL CONTRACT CHANGE (PERCENT)	3.61%

ACCEPTED BY:

PAVING PLUS, LLC

DATE



# Estimate

Date	Estimate #
3/30/2026	10710

PO Box 464  
Glassboro, NJ 08028

**DBE / WBE / SBE Contractor**

Name / Address
City of Ocean City 115 12th Street Ocean City, NJ 08226

ACCEPTANCE OF PROPOSAL	
Signature _____	
Printed Name & Date _____	
Account #	Project
	Various Alleys

Description	Qty	U/M	Unit P...	Total
CO #2 - Pipe at 20th Install (1) 1' x 1' Inlets in Alley Install 100 LF of 10" PVC Pipe Haul & Dispose of Spoils Repave Pipe Trench with 2" HMA Surface Course & 2" HMA Base Course	100	LF	132	13,200.00
Priced as per the NJDOT Asphalt and Fuel Index for March, 2026 * Unit Prices will prevail if not based on lump sum ** If AC increases, prices will be adjusted accordingly  Price Excludes: Multiple Mobilizations – ADD \$2,500 each additional mob. Night work and/or shift differentials Line Striping / Pavement Markings Excavation of Concrete Roadbase				
Sales Tax				0.00

Phone #	Fax #	E-mail
856-404-9166	856-728-2895	jputz@pavingplusllc.com

<b>Total</b>	\$13,200.00
--------------	-------------

**CITY OF OCEAN CITY  
CAPE MAY COUNTY, NEW JERSEY**

**RESOLUTION**

**No. 26-152**

**AUTHORIZING CHANGE ORDER #2 TO CITY CONTRACT #25-11,  
IMPROVEMENTS TO THE PARKING LOT AT 16<sup>TH</sup> STREET & HAVEN AVENUE  
WITH LEXA CONCRETE, LLC**

**WHEREAS**, the specifications were authorized for advertisement by Resolution #25-61-272 on Thursday, February 6, 2025 for City Contract #25-11, Improvements to the Parking Lot at 16<sup>th</sup> Street & Haven Avenue; and

**WHEREAS**, the Notice to Bidders was advertised in the Ocean City Sentinel on Wednesday, March 26, 2025 and the Invitation to Bidders was distributed various potential bidders through the OpenGov E-Procurement Platform; and

**WHEREAS**, the bid proposals were opened for City Contract #25-11, Improvements to the Parking Lot at 16th Street & Haven Avenue on Tuesday, April 8, 2025 and seven (7) bid proposals were received; and

**WHEREAS**, Vincent Orlando, P.E. (Engineering Design Associates); George J. Savastano, Business Administrator; Vincent S. Bekier, Director of Capital Programs, Project Management and Engineering; Christine D. Gundersen, Manager of Capital Planning; Thomas R. Mahar, Purchasing Assistant; Michael Rossbach Jr., QPA, Assistant Purchasing Agent and Joseph S. Clark, Jr., QPA, City Procurement Manager had reviewed the bid proposals and the specifications and recommended that the contract be awarded to Lexa Concrete, LLC as the lowest responsible bidder; and

**WHEREAS**, the City Council of the City of Ocean City authorized the award of City Contract #25-11, Improvements to the Parking Lot at 16th Street & Haven Avenue on Thursday, May 8, 2025 by Resolution #25-62-381 in the total amount of \$1,012,840.00 with \$484,389.60 being charged to Capital Account #C-04-55-327-101 and \$528,450.40 being charged to Capital Account #C-04-55-327-505; and

**WHEREAS**, the City Council of Ocean City authorized Change Order #1 to City Contract #25-11, Improvements to the Parking Lot at 16th Street & Haven Avenue to Lexa Concrete, LLC on Thursday, February 19, 2026 by Resolution #26-66 in the additional amount of \$17,538.88 charged to Capital Account #C-04-55-327-505 for a revised contract total of \$1,030,378.88;

**WHEREAS**, the City of Ocean City has identified an additional number of materials needed to complete the project; and

**WHEREAS**, Vincent Orlando, P.E. (Engineering Design Associates); George J. Savastano, Business Administrator; Vincent S. Bekier, Director of Capital Programs, Project Management and Engineering; Christine D. Gundersen, Manager of Capital Planning; Thomas R. Mahar, Purchasing Assistant; Michael Rossbach Jr., QPA, Procurement Manager have reviewed and certified change order #2 as follows:

<b>Lexa Concrete, LLC 11 Commerce Way Hammonton, NJ 08037</b>
---

**Change Order #2 Supplemental Materials**

<b><u>Item</u></b>	<b><u>Description</u></b>	<b><u>Quantity</u></b>	<b><u>Unit Cost</u></b>	<b><u>Total Cost</u></b>
S-1	Thermo Stripping.....	1 L.S.	\$9,675.00	\$9,675.00
<b>Total Supplemental Materials for Change Order #1 to City Contract #25-11..</b>				<b>\$9,675.00</b>

**CITY OF OCEAN CITY  
CAPE MAY COUNTY, NEW JERSEY**

**RESOLUTION**

No. 26-152

**Change Order #2 Extra Materials**

<u>Item</u>	<u>Description</u>	<u>Quantity</u>	<u>Unit Cost</u>	<u>Total Cost</u>
5.	2" Milling & Repave with Hot Mix Asphalt 9.5 M64 Surface Course, 2' Thick (IF & Where Directed).....	100 S.Y.	\$20.00	\$2,000.00
6.	Hot Mix Asphalt 9.5 M64 Surface Course, 2" Thick.....	52.18 Ton	\$122.00	\$6,365.96
15.	Concrete Gutter, 8" Depth.....	463 L.F.	\$32.00	\$14,816.00
21.	Install Sod.....	778 S.Y.	\$11.50	\$8,947.00
<b>Total Extra Materials for Change Order #2 to City Contract #25-11.....</b>				<b>\$32,128.96</b>

**Change Order #2 Reductions**

<u>Item</u>	<u>Description</u>	<u>Quantity</u>	<u>Unit Cost</u>	<u>Total Cost</u>
4.	12" Ductile Iron Drainage Pipe.....	74 L.F.	\$145.00	(\$10,730.00)
9.	Concrete Driveway, 6" Thick.....	10.55 S.Y.	\$120.00	(\$1,266.00)
10.	Concrete Vertical Curb, 6" Height.....	895 L.F.	\$50.00	(\$44,750.00)
11.	Depressed Curb.....	132 L.F.	\$50.00	(\$6,600.00)
12.	Flesh Curb.....	40 L.F.	\$50.00	(\$2,000.00)
13.	Parking Space Striping.....	1 L.S.	\$3,500.00	(\$3,500.00)
14.	Concrete Sidewalk, 4" Thick.....	134.45 S.Y.	\$110.00	(\$14,789.50)
17.	B Inlet.....	1 Each	\$6,000.00	(\$6,000.00)
18.	12" Dual-Walled HDPE Pipe.....	2 L.F.	\$85.00	(\$170.00)
22.	Top Soil & Seed.....	0.11 S.Y.	\$8.00	(\$0.88)
24.	ADA Detectable Warning Pad.....	4 Each	\$300.00	(\$1,200.00)
33.	Electrical Conduit.....	1488 L.F.	\$12.00	(\$17,856.00)
<b>Total Reduced Amount for Change Order #2 to City Contract #25-11.....</b>				<b>(\$108,862.38)</b>
<b>Total Amount for All Items for Change Order #2 to City Contract #25-11.....</b>				<b>(\$67,058.42)</b>

**CITY OF OCEAN CITY  
CAPE MAY COUNTY, NEW JERSEY**

**RESOLUTION**

**No. 26-152**

**WHEREAS**, the newly adjusted contract cost including Change Order #2 is \$963,320.46, an overall decrease of (\$49,519.54) or -4.89% from the original contract amount of \$1,012,840.00; and

**NOW THEREFORE, BE IT RESOLVED** by the City Council of the City of Ocean City, New Jersey that it authorizes Change Order #2 to Purchase Order #25-01858 for City Contract #25-11, Improvements to the Parking Lot at 16<sup>th</sup> Street & Haven Avenue; and

**BE IT FURTHER RESOLVED** that the Director of Financial Management is authorized to process change order #2, in the reduced amount of (\$67,058.42) to Purchase Order #25-01858 for City Contract #25-11, Improvements to the Parking Lot at 16<sup>th</sup> Street & Haven Avenue to be charged to the following Capital Account #C-04-55-327-101.

**CERTIFICATION OF FUNDS**

\_\_\_\_\_  
Frank Donato III, CFO  
Director of Financial Management

\_\_\_\_\_  
Terry Crowley, Jr.  
Council President

Files: RES CO #2 CC #25-11 16<sup>th</sup> Street.docx

**I HEREBY CERTIFY THAT** the foregoing resolution was duly adopted by the City Council of the City of Ocean City, New Jersey at a Council Meeting held on Thursday, June 11, 2026, with the voting record as indicated below.

NAME	MOTION	SECOND	AYE	NAY	ABSENT	ABSTAINED
Barnes						
Crowley						
Hartzell						
Levchuk						
Madden						
Polcini						
Winslow						

\_\_\_\_\_  
Melissa G. Rasner, City Clerk



CITY OF OCEAN CITY, ENGINEERING DIVISION  
16th & Haven Improvements

CHANGE ORDER NO. 2  
FILE NO. 25-11

PURCHASE ORDER #  
25-01858  
RESOLUTION #  
25-62-351

CONTRACTOR:  
Lexa Concrete  
11 Commerce Way  
Hammonton, NJ 08037

REASON FOR CHANGE:  
See Attached

Revised 5/28/26

THE TIME PROVIDED FOR COMPLETION OF THIS PROJECT IS:  
\_\_\_\_ UNCHANGED, \_\_\_\_\_ INCREASED, \_\_\_\_ DECREASED, BY \_\_\_\_ CALENDAR DAYS.

UPON EXECUTION THIS DOCUMENT SHALL BECOME AN AMENDMENT TO THE CONTRACT.

TYPE OF CHANGE	ITEM #	DESCRIPTION	QTY	UNITS	UNIT PRICE	AMOUNT
SUPPLEMENTAL	S-1	Thermo Striping	1	Lump Sum	\$9,675.00	\$9,675.00
					<b>SUBTOTAL:</b>	\$9,675.00
EXTRA	5	2" Milling & Repave with Hot Mix Asphalt 9.5 M64 Surface Course, 2' Thick (IF & Where Directed)	100	S.Y.	\$20.00	\$2,000.00
	6	Hot Mix Asphalt 9.5 M64 Surface Course, 2" Thick	52.18	Ton	\$122.00	\$6,365.96
	15	Concrete Gutter, 8" Depth	463	L.F.	\$32.00	\$14,816.00
	21	Install Sod	778	S.Y.	\$11.50	\$8,947.00
					<b>SUBTOTAL:</b>	\$32,128.96
REDUCTION	4	12" Ductile Iron Drainage Pipe	74	L.F.	\$145.00	\$10,730.00
	9	Concrete Driveway, 6" Thick	10.55	S.Y.	\$120.00	\$1,266.00
	10	Concrete Vertical Curb, 6" Height	895	L.F.	\$50.00	\$44,750.00
	11	Depressed Curb	132	L.F.	\$50.00	\$6,600.00
	12	Flush Curb	40	L.F.	\$50.00	\$2,000.00
	13	Parking Space Striping	1	Lump Sum	\$3,500.00	\$3,500.00
	14	Concrete Sidewalk, 4" Thick	134.45	S.Y.	\$110.00	\$14,789.50
	17	B Inlet	1	Each	\$6,000.00	\$6,000.00
	18	12" Dual-Walled HDPE Pipe	2	L.F.	\$85.00	\$170.00
	22	Top Soil & Seed	0.11	S.Y.	\$8.00	\$0.88
	24	ADA Detectable Warning Pad	4	Each	\$300.00	\$1,200.00
	33	Electrical Conduit	1488	L.F.	\$12.00	\$17,856.00
					<b>SUBTOTAL:</b>	\$108,862.38

**CHANGE ORDER SUMMARY**

PREVIOUS CHANGE ORDERS		CURRENT CHANGE ORDER	
NO.	AMOUNT	REASON FOR CHANGE	TOTAL
1	\$17,538.88	See Attached	
2	(\$67,058.42)	See Attached	+ SUPPLEMENTAL \$9,675.00
3			
4			+ EXTRA \$32,128.96
5			
6			- REDUCTIONS \$108,862.38
7			
8			NET CONTRACT CHANGE
9			THIS CHANGE ORDER (\$67,058.42)
10			

ORIGINAL CONTRACT AMOUNT	\$1,012,840.00
AMENDED CONTRACT AMOUNT	\$963,320.46
TOTAL CONTRACT CHANGE (PERCENT)	-4.89%
TOTAL CONTRACT CHANGE (AMOUNT)	(\$49,519.54)

ACCEPTED BY:

Lexa Concrete

DATE

# Lexa Concrete, LLC

11 Commerce Way Drive

Hammonton NJ 08037

Ph: 609 704-5293 Fx: 609 704-5355

lexaconcrete@aol.com

05/21/26

RE: 16<sup>th</sup> & Haven Improvements

Lexa Concrete is requesting a Change Order as follows:

Item	Description	Quantity	Unit Price	Total
5	HMA MILLING	100	SY \$20.00	\$2,000.00
5	HMA SURFACE	52.18	TN \$122.00	\$6,365.96
15	8" CONCR GUTTER	463	LF \$32.00	\$14,816.00
21	INSTALL SOD	778	SY \$11.50	\$8,947.00
51	THERMO STRIPING	1	LS \$9,675.00	<u>\$9,675.00</u>
	<b>TOTAL INCREASE</b>			<b>\$41,803.96</b>
4	12" DUCTILE	74	LF \$145.00	\$10,730.00
9	6" CONCRETE DRIVEWAY	10.55	SY \$120.00	\$1,266.00
10	6" CONCRETE CURB	895	LF \$50.00	\$44,750.00
11	DEPRESSED CURB	132	LF \$50.00	\$6,600.00
12	FLUSH CURB	40	LF \$50.00	\$2,000.00
13	PARKING SPACE STRIPING	1	LS \$3,500.00	\$3,500.00
14	4" SIDEWALKS	134.45	SY \$110.00	\$14,789.50
17	TYPE B INLET	1	EA \$6,000.00	\$6,000.00
18	12" DUEAL WALLED HDPE	2	LF \$85.00	\$170.00
22	TOPSOIL/SEED	0.11	SY \$8.00	\$0.88
24	ADA DET WARNING	4	EA \$300.00	\$1,200.00
33	ELECTRICAL CONDUIT	1488	LF \$12.00	\$17,856.00
	<b>TOTAL REDUCTIONS</b>			<b>\$108,862.38</b>

Please review and submit for further processing. Thank you.

# RESOLUTION

No. 26-153

**AUTHORIZING THE FINAL ACCEPTANCE AND FINAL PAYMENT TO CITY  
CONTRACT #24-30, MOORLYN TERRACE BOARDWALK RAMP IMPROVEMENTS  
WITH WEATHERBY CONSTRUCTION & RENOVATION, CORPORATION**

**WHEREAS**, the specifications were authorized for advertisement by Resolution #24-61-046 on Thursday, June 27, 2024 for City Contract #24-30, Moorlyn Terrace Boardwalk Ramp Improvements; and

**WHEREAS**, the Notice to Bidders was advertised in the Ocean City Sentinel on Wednesday, October 16, 2024 and the Invitation to Bidders was distributed to twenty-four (24) prospective bidder(s) for City Contract #24-30, Moorlyn Terrace Boardwalk Ramp Improvements; and

**WHEREAS**, the bid proposals were opened for City Contract #24-30, Moorlyn Terrace Boardwalk Ramp Improvements on Thursday, March 6, 2025 and three (3) bid proposals were received; and

**WHEREAS**, Lamont "Butch" Czar, P.E. (Czar Engineering); George J. Savastano, Business Administrator; Vincent S. Bekier, Director of Capital Programs, Project Management and Engineering; Christine D. Gundersen, Manager of Capital Planning; Thomas R. Mahar, Purchasing Assistant; Michael Rossbach Jr., QPA, Assistant Purchasing Agent and Joseph S. Clark, Jr., QPA, City Procurement Manager have reviewed the bid proposals and the specifications and recommend that the contract be awarded to Weatherby Construction & Renovation, Corporation as the lowest responsible bidder; and

**WHEREAS**, The City Council of the City of Ocean City New Jersey authorized the award of City Contract #24-30, Moorlyn Terrace Boardwalk Ramp Improvements to Weatherby Construction & Renovation Corporation by Resolution #25-61-301 on Thursday, March 13, 2025 in the amount of \$764,000.00 with \$211,287.88 being charged to Grant Account #G-02-40-181-264, \$183,460.70 being charged to Grant Account #G-02-40-181-276, \$182,433.00 being charged to Grant Account #G-02-40-181-296 and \$186,818.42 being charged to Capital Account #C-04-55-332-001; and

**WHEREAS**, The City Council of the City of Ocean City New Jersey authorized Change Order #1 to City Contract #24-30, Moorlyn Terrace Boardwalk Ramp Improvements to Weatherby Construction & Renovation Corporation by Resolution #25-62-518 on Thursday, October 23, 2025 in the increased amount of \$171,513.00 charged to Capital Account #C-04-55-332-001 for a revised contract total of \$935,513.00, an overall increase of \$171,513.00 or 22.45% to Purchase Order #25-00679; and

**WHEREAS**, Lamont "Butch" Czar, P.E. (Czar Engineering); George J. Savastano, Business Administrator; Vincent S. Bekier, Director of Capital Programs, Project Management and Engineering; Christine D. Gundersen, Manager of Capital Planning; Thomas R. Mahar, Purchasing Assistant; Michael Rossbach Jr., QPA, City Purchasing Manager have reviewed and certified the final acceptance and final payment to Weatherby Construction & Renovation, Corporation; and

**CITY OF OCEAN CITY  
CAPE MAY COUNTY, NEW JERSEY**

**RESOLUTION**

**No. 26-153**

**NOW THEREFORE, BE IT FURTHER RESOLVED** by the City Council of the City of Ocean City, New Jersey that it authorizes the final acceptance and final payment in the amount of \$18,710.26 for City Contract #24-30, Moorlyn Terrace Boardwalk Ramp Improvements; and

**BE IT FURTHER RESOLVED** that the Director of Financial Management is authorized to process the final acceptance and final payment in the amount of \$18,710.26 to City Contract #24-30, Moorlyn Terrace Boardwalk Ramp Improvements to be charged to Grant Account #G-02-40-181-238 (PO #25-00679).

**CERTIFICATION OF FUNDS**

\_\_\_\_\_  
Frank Donato III, CFO  
Director of Financial Management

\_\_\_\_\_  
Terry Crowley, Jr.  
Council President

Files: RAW FAFP #24-30 Moorlyn Terrace Boardwalk Ramp Improvements.docx

**I HEREBY CERTIFY THAT** the foregoing resolution was duly adopted by the City Council of the City of Ocean City, New Jersey at a Council Meeting held on Thursday, June 11, 2026, with the voting record as indicated below.

NAME	MOTION	SECOND	AYE	NAY	ABSENT	ABSTAINED
Barnes						
Crowley						
Hartzell						
Levchuk						
Madden						
Polcini						
Winslow						

\_\_\_\_\_  
Melissa G. Rasner, City Clerk



# CITY OF OCEAN CITY

## AMERICA'S GREATEST FAMILY RESORT

### MEMORANDUM

TO: George Savastano, Business Administrator  
FROM: Vince Bekier, Director of Capital Programs, Project Management & Engineering  
CC: Michael Rossbach, Jr., Purchasing Manager  
DATE: May 15, 2026  
RE: FINAL ACCEPTANCE AND CLOSE OUT  
Moorlyn Terrace Boardwalk Ramp Improvements

Project #: 24-30

The above referenced contract is seeking Council's approval of Final Payment and Final Acceptance to Close-Out on the Thursday, June 11, 2026 City Council Agenda. The Contractor's Release of Liens, Payment of Debts and Claims and Consent of Surety to Final Payment, have been received.

Original Contract		\$764,000.00
Total Contract Change (Change Order #1)		\$171,513.00
Total Amended Contract		\$935,513.00
Less Previous Payments	\$	916,802.74
Total Due including Retainage & Final Change Order	\$	18,710.26

Reductions and additions adjusted to meet as-builts of the contract for a net change of 22.45%

115 E. 12<sup>th</sup> Street, OCEAN CITY, NJ 08226  
609-399-6111

[www.ocnj.us](http://www.ocnj.us)



**CITY OF OCEAN CITY  
CAPE MAY COUNTY, NEW JERSEY**

**RESOLUTION**

**No. 26-154**

**AUTHORIZING THE REJECTION OF BIDS FOR CITY CONTRACT #26-18, SUPPLY AND INSTALLTION OF SOLAR PANELS ON VARIOUS CITY BUILDINGS**

**WHEREAS**, the specifications were authorized for advertisement by Resolution #26-78 on Thursday, March 12, 2026 for City Contract #26-18, Supply and Installation of Solar Panels on Various City Buildings; and

**WHEREAS**, the Notice to Bidders was advertised on the Ocean City Public Notices Webpage on Tuesday, April 14, 2026 and the Invitation to Bidders was distributed to various prospective bidders though the OpenGov E-Procurement platform for City Contract #26-18, Supply and Installation of Solar Panels on Various City Buildings; and

**WHEREAS**, the bid proposals were opened for City Contract #26-18, Supply and Installation of Solar Panels on Various City Buildings on Thursday, April 30, 2026 and one (1) bid proposal was received; and

**WHEREAS**, George J. Savastano, Business Administrator; Michael J. Allegretto, Aid to the Mayor; Thomas R. Mahar, Purchasing Assistant and Michael Rossbach Jr., QPA, City Purchasing Manager have reviewed the bid proposal and have determined to reject the proposal and abandon the project and switch to accepting proposals for a Power Purchase Agreement; and

**WHEREAS**, The City of Ocean City is authorized to reject bids in accordance with N.J.S.A. 40A:11-13.2(d); and

**NOW THEREFORE, BE IT RESOLVED** by the City Council of the City of Ocean City, New Jersey, that City Contract #26-18, Supply and Installation of Solar Panels on Various City Buildings is hereby rejected as stated above.

---

Terry Crowley, Jr.  
Council President

Files: REJ CC #26-18 Solar.docx

**I HEREBY CERTIFY THAT** the foregoing resolution was duly adopted by the City Council of the City of Ocean City, New Jersey at a Council Meeting held on Thursday, June 11, 2026, with the voting record as indicated below.

NAME	MOTION	SECOND	AYE	NAY	ABSENT	ABSTAINED
Barnes						
Crowley						
Hartzell						
Levchuk						
Madden						
Polcini						
Winslow						

---

Melissa G. Rasner, City Clerk

**CITY OF OCEAN CITY  
CAPE MAY COUNTY, NEW JERSEY**

**RESOLUTION**

**No. 26-155**

**AUTHORIZING THE SALE OF CITY PROPERTY THAT  
HAS BEEN DEEMED SURPLUS OR ABANDONED ON GOVDEALS, INC.**

**WHEREAS**, the City of Ocean City desires to dispose of property recovered by the City of Ocean City and/or City property that has been deemed surplus and no longer needed for public use; and

**WHEREAS**, the City of Ocean City it is estimated by the City Purchasing Manager that these items will exceed \$7,950.00 in value, requiring disposition by public sale in accordance to N.J.S.A. 40A:11-36 & 40A:14-157; and

**WHEREAS**, the State of New Jersey permits the sale of surplus property no longer needed for public use or acquired through abandonment, through the use of the Sourcewell Cooperative Purchasing, Online Surplus Auctions & Payment Processing Contract #111424-GDI, and pursuant to the Local Unit Electronic Technology Pilot Program & Study Act, P.L. 2001, c.30; and

**WHEREAS**, Govdeals, Inc. is an authorized Sourcewell Vendor with Contract #111424-GDI; and

**WHEREAS**, the City of Ocean City has the property listed in a memo, attached to this Resolution and desires to sell these items at an online auction along with any items that may be deemed surplus between May 21<sup>st</sup>, 2026 through August 31<sup>st</sup>, 2026; and

**NOW THEREFORE BE IT RESOLVED** by the City Council of the City of Ocean City, New Jersey, that the items recovered by the City of Ocean City and/or City's property that has been deemed surplus and no longer needed for public use is hereby authorized to post an offer to sell the items listed on Schedule A and any other items deemed surplus between June 17<sup>th</sup>, 2026 through July 29<sup>th</sup>, 2026 with GovDeals, Inc., Sourcewell Vendor Contract #041316-GDI, an internet auctioneering service as follows:

Online Auction Site:	www. GovDeals.com
Length of Online Auction:	14 days
Auction Fees:	Paid by Winning Bidder
Method of Payment:	Electronic Payment Only via Credit/Debit Card or Wire
Shipping:	Buyer is responsible to load and transport
Possession:	When payment in full is received
Other Terms:	Items are sold as is where is and without warranty, payment in full is due not later than five (5) business days from the time and date (EST) of the Buyer's Certificate (issued by GovDeals Email) being received.
Minimum Bids:	To be determined by current item appraisal

**BE IT FURTHER RESOLVED** that the City Council of the City of Ocean City authorizes Michael Rossbach, Jr., QPA, City Purchasing Manager to coordinate and direct the sale of surplus items no longer needed for public use between June 17<sup>th</sup>, 2026 through July 29<sup>th</sup>, 2026 with GovDeals, Inc., Sourcewell Vendor Contract #041316-GDI, an internet auctioneering service.

\_\_\_\_\_  
Terry Crowley, Jr.  
Council President

Files: RES GovDeals Summer Surplus 2026.docx

**I HEREBY CERTIFY THAT** the foregoing resolution was duly adopted by the City Council of the City of Ocean City, New Jersey at a Council Meeting held on Thursday, June 11, 2026, with the voting record as indicated below.

NAME	MOTION	SECOND	AYE	NAY	ABSENT	ABSTAINED
Barnes						
Crowley						
Hartzell						
Levchuk						
Madden						
Polcini						
Winslow						

\_\_\_\_\_  
Melissa G. Rasner, City Clerk



# CITY OF OCEAN CITY

AMERICA'S GREATEST FAMILY RESORT

## PURCHASING DIVISION

To: George J. Savastano, Business Administrator  
Michael Rossbach, Jr., QPA, City Purchasing Manager

From: Thomas R. Mahar  
Purchasing Assistant

Date: June 9, 2026

Subject: GovDeals, Inc. Auction

All,

The State of New Jersey permits the sale of surplus property no longer needed for public use or acquired through abandonment. The City has sourced GovDeals, Inc. through the Sourcewell Cooperative Purchasing Agreement, Contract #111424-GDI pursuant to the Local Unit Electronic Technology Pilot Program & Study Act, P.L. s002, c.30. The City has determined that eighteen (18) vehicles & various miscellaneous surplus items from the Department of Fire & Rescue Services, the Department of Public Works and the Department of Police Services and no longer being used for City operations. Eighteen (18) surplus operational vehicles and several various Department of Fire & Rescue Services, the Department of Public Works and the Department of Police Services items are expected to be auctioned off on Wednesday, June 17, 2026 and will be live on auction to the public for fourteen (14) days.

The City Purchasing Division will place an advertisement in the Ocean City Sentinel on Wednesday, June 17, 2026 announcing the sale of these vehicles and other miscellaneous items. Following the advertisement these items are anticipated to be listed for auction the same day and will be available for fourteen (14) days. Below is the list of items the City would like to auction off on GovDeals:

### Surplus Vehicles

1989 A.M. General M923 Cargo 6x6:  
VIN #NLOMAHC52308763  
2004 Ford E350 Van: VIN #1FBSS31L44HB37712  
2011 Ford Crown Victoria: VIN #2FABP7BV7BX106929  
2010 Ford Explorer: VIN #1FME47DEXAUA47048  
2009 Sterling Acterra Hooklift: VIN #2FZACFDJ69AAM3170  
2006 Ford E150 Van: VIN #1FTRE14W26DA93070  
2015 Polaris Ranger 570: VIN# 3NSRCA57XGG515151  
2017 Sportsman 570 Quad: VIN #4XASEA579HA631459  
2017 Polaris Ranger XP 900  
1992 A.M General M934 Van: VIN #8400440NL0YIV  
2008 Ford Crown Victoria: VIN #2FAHP71V98X180311  
2009 Ford Crown Victoria: VIN #2FAHP71V89X143235  
2010 Ford Crown Victoria: VIN #2FABP7BVOAX141214  
2013 Chevrolet Tahoe: VIN #1GNSK2E08DR372086  
2010 Ford F-150: VIN #1FTFWLEV2AFB33568  
2011 Ford Crown Victoria: VIN #2FABP7BV0BX107954  
2011 Ford Crown Victoria: VIN #2FABP7BV4BX107956  
2011 Ford Crown Victoria: VIN# 2FABP7BV4BX106929

### Miscellaneous Surplus

Assorted Hand Tools  
Hurst Hydraulic Tools and Hoses  
Gas Powered Ventilation Fan  
Search Ropes with Carrying Bags  
Turn-Out Gear  
Inflatable Vests/Harnesses

For a full inventory list please contact the Purchasing department for more information regarding exact item specifics and number of items being allocated for sale in each listing.

Sincerely,

Thomas R. Mahar  
Purchasing Assistant

CITY OF OCEAN CITY  
CAPE MAY COUNTY, NEW JERSEY

**RESOLUTION**

No. 26-156

**APPROVING A SPECIAL EVENT PERMIT  
FOR THE 2026 4<sup>TH</sup> OF JULY FIREWORK DISPLAY**

**WHEREAS**, the City of Ocean City has made application to the Mayor and City Council under the provisions of the Revised General Ordinances of the City of Ocean City, Ordinance No. 95-05, Section 5-17 (1-10) *et. seq.* for a special event permit for fireworks display to be held on Saturday, July 4, 2026 with rain dates to be determined at the time of need by the City of Ocean City; and

**WHEREAS**, the City of Ocean City shall submit all required documentation related to the event, including complete information regarding the fireworks display, the vendor responsible for the fireworks display and appropriate required insurance coverage's and hold harmless agreements; and

**WHEREAS**, said documentation shall be reviewed by the appropriate City officials to include the Fire Chief; and

**WHEREAS**, the City of Ocean City has successfully sponsored safe firework displays on the 4<sup>th</sup> of July in Ocean City for the past thirty-two (32) years; and

**WHEREAS**, Pyrotecnico Fireworks, Inc., d/b/a Pyrotecnico, the vendor responsible for the fireworks display, has produced similar events in the City of Ocean City and the Philadelphia - New Jersey metropolitan area; and

**NOW, THEREFORE, BE IT RESOLVED** by the City Council of Ocean City, that the Mayor is authorized to issue a special event permit to the City for the 2026 4<sup>th</sup> of July Fireworks Display, in accordance with Section 5-17 of the Revised General Ordinances of the City of Ocean City, Ordinance No. 95-05, Section 5-17 (1-10) *et. seq.*

\_\_\_\_\_  
Terry Crowley, Jr.  
Council President

Files: RES 2026 Special Events Permit 4<sup>th</sup> of July Fireworks.docx

**I HEREBY CERTIFY THAT** the foregoing resolution was duly adopted by the City Council of the City of Ocean City, New Jersey at a Council Meeting held on Thursday, June 11, 2026, with the voting record as indicated below.

NAME	MOTION	SECOND	AYE	NAY	ABSENT	ABSTAINED
Barnes						
Crowley						
Hartzell						
Levchuk						
Madden						
Polcini						
Winslow						

\_\_\_\_\_  
Melissa G. Rasner, City Clerk

# City of Ocean City, NJ



## Special Events Permit

Permit: 26-093

Event: July 4th Fireworks Display

Date: July 4th, 2026

Time: 9:00PM

Location: Barge in the Ocean off 9th Street

Contact Person: Daniel Kelchner

Conditions:

This permit is issued in accordance with Ocean City Ordinance #95-05 and is contingent on adherence to all conditions described above and contained in application submitted for this event. This permit is additionally contingent on possession of any other permits or licenses required by local or state laws and regulations. As per City ordinance, no alcoholic beverages or smoking are permitted on or in City properties. You will also be responsible for any damage to the facility/equipment during your event. As this building is used on a regular basis for City sponsored programs please DO NOT remove any supplies/projects from walls or bulletin boards. If any of these rules are violated the City of Ocean City reserves the right to terminate this and any future contracts.

C: Dept. of Administration, Dept. of Community Services, Dept. of Financial Management, Dept. of Fire & Rescue, Dept. of Public Safety, Dept of Public Works

**CITY OF OCEAN CITY  
CAPE MAY COUNTY, NEW JERSEY**

**RESOLUTION**

**No. 26-157**

**APPROVING A SPECIAL EVENT PERMIT FOR THE 2026  
NIGHT IN VENICE FIREWORK DISPLAY**

**WHEREAS**, the City of Ocean City has made application to the Mayor and City Council under the provisions of the Revised General Ordinances of the City of Ocean City, Ordinance No. 95-05, Section 5-17 (1-10) *et. seq.* for a special event permit for a firework display to be held on July 25, 2025 with rain dates to be determined at the time of need by the City of Ocean City; and

**WHEREAS**, the City of Ocean City shall submit all required documentation related to the event, including complete information regarding the fireworks display, the vendor responsible for the fireworks display and appropriate required insurance coverage's and hold harmless agreements; and

**WHEREAS**, said documentation shall be reviewed by the appropriate City officials to include the Fire Chief; and

**WHEREAS**, the City of Ocean City has successfully sponsored safe firework displays on various occasions in Ocean City for the past number of years; and

**WHEREAS**, Pyrotecnico Fireworks, Inc., d/b/a Pyrotecnico, the vendor responsible for the fireworks display, has produced similar events in the City of Ocean City and the Philadelphia - New Jersey metropolitan area; and

**NOW, THEREFORE, BE IT RESOLVED** by the City Council of Ocean City, that the Mayor is authorized to issue a special event permit to the City for the July 25, 2026 Night in Venice Fireworks Display, in accordance with Section 5-17 of the Revised General Ordinances of the City of Ocean City, Ordinance No. 95-05, Section 5-17 (1-10) *et. seq.*

\_\_\_\_\_  
Terry Crowley, Jr.  
Council President

Files: RES 2026 Special Events Permit NIV.docx

**I HEREBY CERTIFY THAT** the foregoing resolution was duly adopted by the City Council of the City of Ocean City, New Jersey at a Council Meeting held on Thursday, June 11, 2026, with the voting record as indicated below.

NAME	MOTION	SECOND	AYE	NAY	ABSENT	ABSTAINED
Barnes						
Crowley						
Hartzell						
Levchuk						
Madden						
Polcini						
Winslow						

\_\_\_\_\_  
Melissa G. Rasner, City Clerk

# City of Ocean City, NJ



## Special Events Permit

Permit: 26-094

Event: Night In Venice Fireworks Display

Date: July 25th, 2026

Time: 9:00PM

Location: Barge in the Great Egg Harbor Bay

Contact Person: Daniel Kelchner

### Conditions:

This permit is issued in accordance with Ocean City Ordinance #95-05 and is contingent on adherence to all conditions described above and contained in application submitted for this event. This permit is additionally contingent on possession of any other permits or licenses required by local or state laws and regulations. As per City ordinance, no alcoholic beverages or smoking are permitted on or in City properties. You will also be responsible for any damage to the facility/equipment during your event. As this building is used on a regular basis for City sponsored programs please DO NOT remove any supplies/projects from walls or bulletin boards. If any of these rules are violated the City of Ocean City reserves the right to terminate this and any future contracts.

C: Dept. of Administration, Dept. of Community Services, Dept. of Financial Management, Dept. of Fire & Rescue, Dept. of Public Safety, Dept of Public Works

CITY OF OCEAN CITY  
CAPE MAY COUNTY, NEW JERSEY

**RESOLUTION**

No. 26-158

**APPROVING A SPECIAL EVENT PERMIT FOR THE 2026-2027 FIRST NIGHT  
FIREWORK DISPLAY**

**WHEREAS**, First Night Ocean City, Inc. has made application to the Mayor and City Council under the provisions of the Revised General Ordinances of the City of Ocean City Ordinance No. 95-05, Section 5-17 (1-10) *et. seq.* for a special event permit for a firework display to be held on December 31, 2026; and

**WHEREAS**, First Night Ocean City, Inc. shall submit all required documentation related to the event, including complete information regarding the fireworks display, the vendor responsible for the fireworks display and appropriate required insurance coverage's and hold harmless agreements; and

**WHEREAS**, said documentation shall be reviewed by the appropriate City officials to include the Fire Chief; and

**WHEREAS**, First Night Ocean City, Inc. has successfully sponsored safe firework displays on New Year's Eve in Ocean City for the past thirty-two (32) years; and

**WHEREAS**, Pyrotecnico Fireworks, Inc., d/b/a Pyrotecnico, the vendor responsible for the fireworks display, has produced similar events in Philadelphia New Jersey metropolitan area; and

**NOW THEREFORE, BE IT RESOLVED** by the City Council of Ocean City, that the Mayor is authorized to issue a special event permit to the First Night Ocean City, Inc. for a First Night Fireworks Display, in accordance with Section 5-17 of the Revised General Ordinances of the City of Ocean City, Ordinance No. 95-05, Section 5-17 (1-10) *et. seq.*

---

Terry Crowley, Jr.  
Council President

Files: RES 2026 Special Events Permit NIV.docx

**I HEREBY CERTIFY THAT** the foregoing resolution was duly adopted by the City Council of the City of Ocean City, New Jersey at a Council Meeting held on Thursday, June 11, 2026, with the voting record as indicated below.

NAME	MOTION	SECOND	AYE	NAY	ABSENT	ABSTAINED
Barnes						
Crowley						
Hartzell						
Levchuk						
Madden						
Polcini						
Winslow						

---

Melissa G. Rasner, City Clerk

# City of Ocean City, NJ

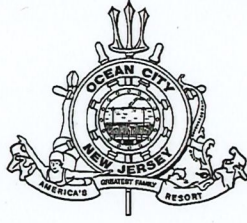

## Special Events Permit

Permit: 26-095

Event: First Night Fireworks Display

Date: December 31st, 2026

Time: 12:00AM

Location: 5th & Boardwalk

Contact Person: Daniel Kelchner

Conditions:

This permit is issued in accordance with Ocean City Ordinance #95-05 and is contingent on adherence to all conditions described above and contained in application submitted for this event. This permit is additionally contingent on possession of any other permits or licenses required by local or state laws and regulations. As per City ordinance, no alcoholic beverages or smoking are permitted on or in City properties. You will also be responsible for any damage to the facility/equipment during your event. As this building is used on a regular basis for City sponsored programs please DO NOT remove any supplies/projects from walls or bulletin boards. If any of these rules are violated the City of Ocean City reserves the right to terminate this and any future contracts.

C: Dept. of Administration, Dept. of Community Services, Dept. of Financial Management, Dept. of Fire & Rescue, Dept. of Public Safety, Dept of Public Works

CITY OF OCEAN CITY  
CAPE MAY COUNTY, NEW JERSEY

**RESOLUTION**

No. 26-159

**AUTHORIZING THE EXECUTION OF A REVOCABLE LICENSE FOR FENCE ENCROACHMENT FOR PLACEMENT OF A FENCE WITHIN THE CITY RIGHT-OF-WAY KNOWN AS WEST AVENUE ADJACENT TO THE PROPERTY LOCATED AT 1651 WEST AVENUE, BLOCK 1604, LOT 5.01.**

**WHEREAS**, Michael Rotay, Joelle Rotay, and David Rotay (hereinafter, "Licensees") are the owners of the property shown as Block 1604, Lot 5.01 on the Official Tax Map of the City of Ocean City, also known as 1651 West Avenue (hereinafter, the "Property"); and

**WHEREAS**, the Property is adjacent to City's right-of-way known as West Avenue; and

**WHEREAS**, the Licensees wish to construct a fence along the City's right-of-way rather than along the Property's property line in order to enhance the safety of their front yard; and,

**WHEREAS**, City officials have inspected the property and determined that placement of the fence three (3") inches from the adjacent edge of the existing sidewalk as detailed on the drawing provided for same, can be performed in a manner that does not diminish public use of the right-of-way, nor impede pedestrian, bicycle or vehicular traffic, nor interfere with sight triangles or sight lines; and,

**WHEREAS**, City officials are of the opinion that in this particular location, it would be preferable for the proposed fence three (3") inches from the edge of the sidewalk than along the property lines of Block 1604, Lot 5.01; and,

**WHEREAS**, Licensees seek permission from the governing body to place their fence within the public right-of-way with the understanding that such permission will be in the form of a revocable license, that the Licensees shall be solely responsible to maintain the fence in good repair in a neat, safe and orderly fashion at Licensees' sole expense and that they will be required to indemnify and hold the City harmless from any liability of any kind, nature or description; and will be required to annually provide proof that the City has been named an additional insured on the Licensees' insurance policy or annually provide such other form of hold harmless and indemnification as the City Solicitor, in the sound discretion of the City Solicitor, may approve;

**NOW, THEREFORE, BE IT RESOLVED** that the governing body of the City of Ocean City hereby authorizes the execution of a Revocable License For Fence Encroachment allowing the fence proposed to be installed by the owners of Block 1604, Lot 5.01 to encroach onto the City right-of-way under the terms and conditions as set forth in the Agreement attached hereto and made a part hereof.

The Business Administrator or his designee is hereby authorized to execute the Revocable License For Fence Encroachment.

\_\_\_\_\_  
Terry Crowley, Jr.,  
Council President

**I HEREBY CERTIFY THAT** the foregoing resolution was duly adopted by the City Council of the City of Ocean City, New Jersey at a Council Meeting held on Thursday, June 11, 2026 with the voting record as indicated below.

NAME	MOTION	SECOND	AYE	NAY	ABSENT	ABSTAINED
Barnes						
Crowley						
Hartzell						
Levchuk						
Madden						
Polcini						
Winslow						

\_\_\_\_\_  
Melissa G. Rasner, City Clerk

## REVOCABLE LICENSE FOR FENCE ENCROACHMENT

Agreement made, effective as of \_\_\_\_\_, 2026, by and between **THE CITY OF OCEAN CITY**, a Municipal Corporation of the State of New Jersey, of 861 Asbury Avenue, Ocean City, NJ 08226 (hereinafter "**City**"), which is the owner of a certain 100' wide right-of-way known as West Avenue, and **MICHAEL ROTAY, JOELLE ROTAY** and **DAVID ROTAY**, whose address is 1231 Erin Court, Collegetown, PA, 19426, owners of 1651 West Avenue, Ocean City, NJ 08226 (hereinafter collectively "**LICENSEES**").

WITNESSETH:

A. LICENSEES are the owners of Block 1604, Lot 5.01 situated in the City of Ocean City, County of Cape May and State of New Jersey (hereinafter, the "Property"), and City is the owner of the 100' wide right-of-way known as West Avenue adjacent to the northwesterly side of the Property (see copy of survey prepared by Design Land Surveying P.A., dated July 3, 2025, last revised on December 30, 2025, and marked up by the applicant on or about March 16, 2026, attached hereto as Exhibit A).

B. LICENSEES propose to install a fence in order to enhance the safety of their front yard and would like to install the fence three (3") inches from the adjacent edge of the existing sidewalk, rather than on the property line of the Property.

C. LICENSEES and City desire to create a revocable encroachment license over the area between the property line of the Property and the fence to be constructed by LICENSEES, and permit LICENSEES to install a conforming, open fence along the adjacent edge of the existing sidewalk for the benefit of the Property, subject to the terms and conditions hereinafter set forth.

LICENSEES and City agree as follows:

A revocable license for the proposed a conforming, open fence along the adjacent edge of the existing sidewalk in favor of the LICENSEES' property is created over that portion of the City right-of-way adjacent to Block 1604, Lot 5.01 and located as depicted on the attached Exhibit A.

This revocable license agreement is specifically intended to and shall run with the land and shall benefit and bind LICENSEE and its successors in title until (a) the fence to be installed in accordance herewith is demolished or removed, after which there shall be no license or other permission for the replacement or reconstruction of any improvements within the public sidewalk, street or right-of-way; or (b) until this revocable license is revoked and extinguished by the City upon 90 days written notice to LICENSEES, or LICENSEES' successor in title, after which the encroachment shall be completely removed and the public right-of-way restored in a manner

consistent with the immediately surrounding area (be it grassed or concrete) at the sole expense of LICENSEES or LICENSEES' successor in title.

LICENSEES shall be responsible for the care and maintenance of the fence. The LICENSEES shall maintain said encroachment in good repair in a neat, safe and orderly fashion, at LICENSEES' sole expense. Similarly, LICENSEES shall indemnify and hold City, its elected officials, employees and agents harmless from any liability of any kind, nature or description, whether with respect to property damage, property repair, personal injury, etc., which may occur as a result of the existence of this revocable license for encroachment, and LICENSEES shall add City as an additional insured on the liability portion of LICENSEES' insurance policy for LICENSEES' premises, as City's interests may appear, as the provider of this revocable license. LICENSEES shall furnish City with a copy of an insurance certificate which complies herewith (or such other form of hold harmless and indemnification as the City Solicitor, in the sound discretion of the City Solicitor, may approve). It shall be LICENSEES' responsibility after full execution of this license to record this license with the Cape May County Clerk's Office and provide a copy of the recorded document to the City.

IN WITNESS WHEREOF, LICENSEES and the City have caused this agreement to be executed, their signatures notarized, and the date of the agreement being set forth as the date of the first to sign, as indicated above, with the completed document and exhibits to then be recorded in the Office of the Cape May County Clerk by LICENSEES.

*SIGNATURE PAGE FOLLOWS*

CITY OF OCEAN CITY, LICENSOR

Attest: \_\_\_\_\_

By: \_\_\_\_\_

STATE OF NEW JERSEY :  
: SS.  
COUNTY OF CAPE MAY :

BE IT REMEMBERED that on this \_\_\_\_\_ day of \_\_\_\_\_, 2026, before me, the subscriber, the undersigned authority, personally appeared **JAY A. GILLIAN, MAYOR** for the CITY OF OCEAN CITY and **MELISSA RASNER, CITY CLERK** for the CITY OF OCEAN CITY, known to me or satisfactorily proven to be the persons who signed the within instrument and acknowledged that they signed, sealed and delivered the same as their voluntary act and deed on behalf of the CITY OF OCEAN CITY for the uses and purposes therein expressed. All of which is hereby certified.

\_\_\_\_\_  
*Notary Public*

\_\_\_\_\_  
MICHAEL ROTAY, LICENSEE

\_\_\_\_\_  
JOELLE ROTAY, LICENSEE

\_\_\_\_\_  
DAVID ROTAY, LICENSEE

STATE OF NEW JERSEY :  
: SS.  
COUNTY OF CAPE MAY :

BE IT REMEMBERED that on this \_\_\_\_\_ day of \_\_\_\_\_, 2026, before me, the subscriber, the undersigned authority, personally appeared **MICHAEL ROTAY**, who I am satisfied is the person who signed the within instrument and acknowledged that he signed, sealed and delivered the same as his act and deed for the uses and purposes therein expressed. All of which is hereby certified.

\_\_\_\_\_  
*Notary Public*

STATE OF NEW JERSEY :  
: SS.  
COUNTY OF CAPE MAY :

BE IT REMEMBERED that on this \_\_\_\_\_ day of \_\_\_\_\_, 2026, before me, the subscriber, the undersigned authority, personally appeared **JOELLE ROTAY**, who I am satisfied is the person who signed the within instrument and acknowledged that she signed, sealed and delivered the same as her act and deed for the uses and purposes therein expressed. All of which is hereby certified.

\_\_\_\_\_  
*Notary Public*

STATE OF NEW JERSEY :

: SS.  
COUNTY OF CAPE MAY :

BE IT REMEMBERED that on this \_\_\_\_\_ day of \_\_\_\_\_, 2026, before me, the subscriber, the undersigned authority, personally appeared **DAVID ROTAY**, who I am satisfied is the person who signed the within instrument and acknowledged that he signed, sealed and delivered the same as his act and deed for the uses and purposes therein expressed. All of which is hereby certified.

---

*Notary Public*



# STANDARD | 4' X 8' CAPE COD

CLASSIC PICKET | STRAIGHT | VERTEX BASE RAIL



DESCRIPTION	WHITE		SAND	
	QTY	SKU	QTY	SKU
4' x 8' Cape Cod Classic Picket Straight Panel (48"H)		73011681		73011687
5" x 5" x 84" Line Post (B)		73011754		73011760
5" x 5" x 84" Corner Post (B)		73011755		73011761
5" x 5" x 84" End Gate Post (B)		73011756		73011762
5" x 5" Pyramid Post Cap		73003093		73003769
5" x 5" Gothic Post Cap		73003094		73003760
5" x 5" New England Post Cap		73045003		73045004
4' x 46" Cape Cod Classic Picket Straight Walk Gate		73014743		73014745
4' x 58" Cape Cod Classic Picket Straight Drive Gate		73014744		73014746
5" x 5" x 82" Gate Post Insert			73003718	

**QS** QuickShip available in White and Sand only. Applies to: Fence Panels; Line, Corner, End and Gate Posts; and 4' and 5' Wide Gates.

## WALK GATE

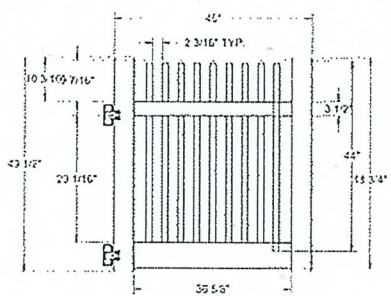

## FENCE PANEL

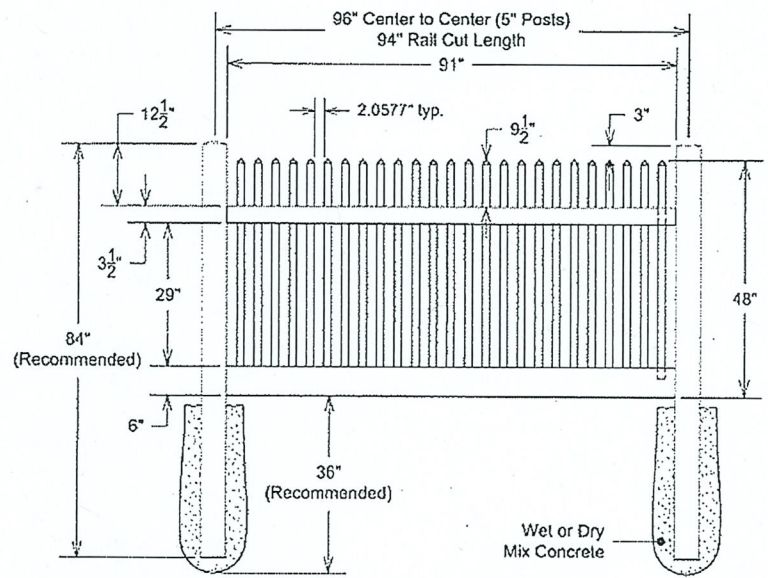

## DRIVE GATE

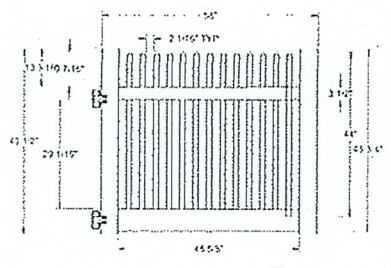

## MATERIAL PER SECTION

QTY	ITEM	DIMENSION
1	Top Rail	2" x 3 1/2" x 94"
1	Bottom Rail	2" x 6" x 94"
25	Picket Caps	1 1/2" x 1 1/2"
25	Pickets	1 1/2" x 1 1/2" x 43 3/16"

## RAIL PROFILE



VERTEX BASE  
1 1/2" x 5 1/2"

CITY OF OCEAN CITY  
CAPE MAY COUNTY, NEW JERSEY

**RESOLUTION**

No. 26-160

**AUTHORIZING THE EXECUTION OF A REVOCABLE LICENSE FOR FENCE ENCROACHMENT FOR PLACEMENT OF A FENCE WITHIN THE CITY RIGHT-OF-WAY KNOWN AS ASBURY AVENUE ADJACENT TO THE PROPERTY LOCATED AT 5429-31 ASBURY AVENUE, BLOCK 5402, LOT 7.02.**

**WHEREAS**, the 5429-31 Asbury Avenue Condominium Association is an unincorporated association governing the 2-unit condominium location at 5429-31 Asbury Avenue, (shown on the Ocean City tax map as Block 5402, Lot 7.02) (hereinafter, the "Property") known as 5429-31 Asbury Avenue Condominium, the master deed for which was recorded in the Office of the Cape May County Clerk on March 14, 2018 in Deed Book 3780, Page 926; and

**WHEREAS**, Rose M. Marnell and Pasquale Diamond (hereinafter, "Marnell & Diamond") are the owners of the first-floor condominium unit at the Property; and

**WHEREAS**, Paul J. and Mae C .Major, Jr. (hereinafter, "Majors") are the owners of the second-floor condominium unit at the Property (hereinafter, Marnell & Diamond and the Majors shall be referred to collectively as "Licensees"); and

**WHEREAS**, the Property is adjacent to City's right-of-way known as Asbury Avenue; and

**WHEREAS**, the Licensees wish to construct a fence along the City's right-of-way rather than along the Property's property line in order to enhance the safety of their front yard; and

**WHEREAS**, City officials have inspected the property and determined that placement of the fence along the edge of the existing sidewalk as shown on the drawing provided for same can be performed in a manner that does not diminish public use of the right-of-way, nor impede pedestrian, bicycle or vehicular traffic, nor interfere with sight triangles or sight lines; and,

**WHEREAS**, City officials are of the opinion that in this particular location, it would be preferable for the proposed fence to be installed along the edge of the existing sidewalk than along the property line of Block 5402, Lot 7.02; and,

**WHEREAS**, Licensees seek permission from the governing body to place their fence within the public right-of-way with the understanding that such permission will be in the form of a revocable license, that the Licensees shall be solely responsible to maintain the fence in good repair in a neat, safe and orderly fashion at Licensees' sole expense; and that they will be required to indemnify and hold the City harmless from any liability of any kind, nature or description; and will be required to annually provide proof that the City has been named an additional insured on the Licensees' insurance policy or annually provide such other form of hold harmless and indemnification as the City Solicitor, in the sound discretion of the City Solicitor, may approve;

**NOW, THEREFORE, BE IT RESOLVED** that the governing body of the City of Ocean City hereby authorizes the execution of a Revocable License For Fence Encroachment allowing the fence proposed to be installed by the owners of Block 5402, Lot 7.02 to encroach onto the City right-of-way under the terms and conditions as set forth in the Agreement attached hereto and made a part hereof.

The Business Administrator or his designee is hereby authorized to execute the Revocable License For Fence Encroachment.

\_\_\_\_\_  
Terry Crowley, Jr.  
Council President

**I HEREBY CERTIFY THAT** the foregoing resolution was duly adopted by the City Council of the City of Ocean City, New Jersey at a Council Meeting held on Thursday, June 11, 2026 with the voting record as indicated below.

NAME	MOTION	SECOND	AYE	NAY	ABSENT	ABSTAINED
Barnes						
Crowley						
Hartzell						
Levchuk						
Madden						
Polcini						
Winslow						

\_\_\_\_\_  
Melissa G. Rasner, City Clerk

## REVOCABLE LICENSE FOR FENCE ENCROACHMENT

Agreement made, effective as of \_\_\_\_\_, 2026, by and between

**THE CITY OF OCEAN CITY**, a Municipal Corporation of the State of New Jersey, of 861 Asbury Avenue, Ocean City, NJ 08226 (hereinafter "**City**"), which is the owner of a certain 65' wide right-of-way known as Asbury Avenue; and

**5429-31 ASBURY AVENUE CONDOMINIUM ASSOICATION** an unincorporated association governing the 2-unit condominium location at 5429-31 Asbury Avenue, (shown on the Ocean City tax map as Block 5402, Lot 7.02) (hereinafter, the "**Property**") known as 5429-31 Asbury Avenue Condominium, the master deed for which was recorded in the Office of the Cape May County Clerk on March 14, 2018 in Deed Book 3780, Page 926; **ROSE M. MARNELL** and **PASQUALE DIAMOND**, of 5429 Asbury Avenue, Ocean City, NJ 08226, owners of 5429-31 Asbury Avenue, UNIT A – 1<sup>st</sup> Floor; and **PAUL J.** and **MAE C. MAJOR, JR.**, of 302 Cambridge Drive, Royersford, PA 19468, owners of 5429-31 Asbury Avenue, Unit B – 2<sup>nd</sup> Floor (hereinafter collectively "**LICENSEES**").

WITNESSETH:

A. LICENSEES are the owners of Block 5402, Lot 7.02, C1 and C2, situated in the City of Ocean City, County of Cape May and State of New Jersey (hereinafter, the "**Property**"), and City is the owner of the 65' wide right-of-way known as Asbury Avenue adjacent to the northwesterly side of the Property (see partial copy of survey marked up by the applicant on or about March 23, 2026, attached hereto as Exhibit A).

B. LICENSEES propose to install a fence in order to enhance the safety of their front yard and would like to install the fence along the adjacent edge of the existing sidewalk, rather than on the property line of the Property.

C. LICENSEES and City desire to create a revocable encroachment license over the area between the property line of the Property and the fence to be constructed by LICENSEES, and permit LICENSEES to install a conforming fence along the adjacent edge of the existing sidewalk for the benefit of the Property, subject to the terms and conditions hereinafter set forth.

LICENSEES and City agree as follows:

A revocable license for the proposed a conforming fence along the adjacent edge of the existing sidewalk in favor of the LICENSEES' property is created over that portion of the City right-of-way adjacent to Block 5402, Lot 7.02 and located as depicted on the attached Exhibit A.

This revocable license agreement is specifically intended to and shall run with the land and shall benefit and bind LICENSEES and its successors in title until (a) the fence to be installed in accordance herewith is demolished or removed, after which there shall be no license or other permission for the replacement or reconstruction of any improvements within the public sidewalk, street or right-of-way; or (b) until this revocable license is revoked and extinguished by the City upon 90 days written notice to LICENSEES, or LICENSEES' successor in title, after which the encroachment shall be completely removed and the public right-of-way restored in a manner consistent with the immediately surrounding area (be it grassed or concrete) at the sole expense of LICENSEES or LICENSEES' successor in title.

LICENSEES shall be responsible for the care and maintenance of the fence. The LICENSEES shall maintain said encroachment in good repair in a neat, safe and orderly fashion, at LICENSEES' sole expense. Similarly, LICENSEES shall indemnify and hold City, its elected officials, employees and agents harmless from any liability of any kind, nature or description, whether with respect to property damage, property repair, personal injury, etc., which may occur as a result of the existence of this revocable license for encroachment, and LICENSEES shall add City as an additional insured on the liability portion of LICENSEES' insurance policy for LICENSEES' premises, as City's interests may appear, as the provider of this revocable license. LICENSEES shall furnish City with a copy of an insurance certificate which complies herewith (or such other form of hold harmless and indemnification as the City Solicitor, in the sound discretion of the City Solicitor, may approve). It shall be LICENSEES' responsibility after full execution of this license to record this license with the Cape May County Clerk's Office and provide a copy of the recorded document to the City.

IN WITNESS WHEREOF, LICENSEES and the City have caused this agreement to be executed, their signatures notarized, and the date of the agreement being set forth as the date of the first to sign, as indicated above, with the completed document and exhibits to then be recorded in the Office of the Cape May County Clerk by LICENSEES.

*SIGNATURE PAGE FOLLOWS*

CITY OF OCEAN CITY, LICENSOR

Attest: \_\_\_\_\_

By: \_\_\_\_\_

STATE OF NEW JERSEY :  
: SS.  
COUNTY OF CAPE MAY :

BE IT REMEMBERED that on this \_\_\_\_\_ day of \_\_\_\_\_, 2026, before me, the subscriber, the undersigned authority, personally appeared **JAY A. GILLIAN, MAYOR** for the CITY OF OCEAN CITY and **MELISSA RASNER, CITY CLERK** for the CITY OF OCEAN CITY, known to me or satisfactorily proven to be the persons who signed the within instrument and acknowledged that they signed, sealed and delivered the same as their voluntary act and deed on behalf of the CITY OF OCEAN CITY for the uses and purposes therein expressed. All of which is hereby certified.

\_\_\_\_\_  
*Notary Public*

5429-31 ASBURY AVENUE CONDOMINIUM  
ASSOCIATION, LICENSEE

\_\_\_\_\_  
ROSE M. MARNELL, OWNER OF UNIT A

\_\_\_\_\_  
PASQUALE DIAMOND, OWNER OF UNIT A

\_\_\_\_\_  
PAUL J. MAJOR, JR., OWNER OF UNIT B

\_\_\_\_\_  
MAE C. MAJOR, OWNER OF UNIT B

STATE OF NEW JERSEY :  
: SS.  
COUNTY OF CAPE MAY :

BE IT REMEMBERED that on this \_\_\_\_\_ day of \_\_\_\_\_, 2026, before me, the subscriber, the undersigned authority, personally appeared **ROSE M. MARNELL** who I am satisfied is the person who signed the within instrument and acknowledged that she signed, sealed and delivered the same as her act and deed for the uses and purposes therein expressed. All of which is hereby certified.

\_\_\_\_\_  
*Notary Public*



BURY AVENUE (65' WIDE)

36"  
High

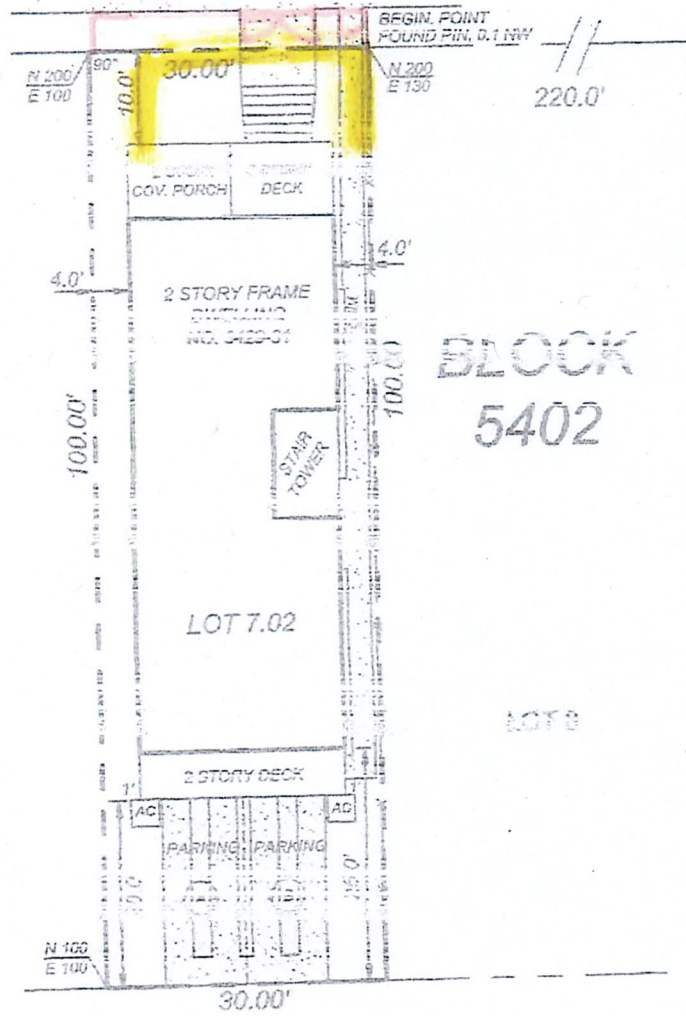

BLOCK  
5402

FIFTY-FOURTH STREET (50' WIDE)

16 FEET WIDE PUBLIC ALLEY

**CITY OF OCEAN CITY  
CAPE MAY COUNTY, NEW JERSEY**

**RESOLUTION**

**No. 26-161**

**AUTHORIZING THE EXECUTION OF A REVOCABLE LICENSE FOR FENCE ENCROACHMENT  
FOR PLACEMENT OF A FENCE WITHIN THE CITY RIGHT-OF-WAY KNOWN AS WEST  
AVENUE ADJACENT TO THE PROPERTY LOCATED AT 1817 WEST AVENUE, BLOCK 1804,  
LOT 8.**

**WHEREAS**, Patrick J. & Karen Foley and Christopher & Shannan Kokocha (hereinafter, "Licensees") are the owners of the property shown as Block 1804, Lot 8 on the Official Tax Map of the City of Ocean City, also known as 1817 West Avenue (hereinafter, the "Property"); and

**WHEREAS**, the Property is adjacent to City's right-of-way known as West Avenue; and

**WHEREAS**, the Licensees wish to construct a fence along the City's right-of-way rather than along the Property's property line in order to enhance the safety of their front yard; and,

**WHEREAS**, City officials have inspected the property and determined that placement of the fence along the edge of the existing sidewalk as shown on the drawing provided for same can be performed in a manner that does not diminish public use of the right-of-way, nor impede pedestrian, bicycle or vehicular traffic, nor interfere with sight triangles or sight lines; and,

**WHEREAS**, City officials are of the opinion that in this particular location, it would be preferable for the proposed fence to be installed along the edge of the existing sidewalk than along the property line of Block 1804, Lot 8; and,

**WHEREAS**, Licensees seek permission from the governing body to place their fence within the public right-of-way with the understanding that such permission will be in the form of a revocable license, that the Licensees shall be solely responsible to maintain the fence in good repair in a neat, safe and orderly fashion at Licensees' sole expense; and that they will be required to indemnify and hold the City harmless from any liability of any kind, nature or description; and will be required to annually provide proof that the City has been named an additional insured on the Licensees' insurance policy or annually provide such other form of hold harmless and indemnification as the City Solicitor, in the sound discretion of the City Solicitor, may approve;

**NOW, THEREFORE, BE IT RESOLVED** that the governing body of the City of Ocean City hereby authorizes the execution of a Revocable License For Fence Encroachment allowing the fence proposed to be installed by the owners of Block 1804, Lot 8 to encroach onto the City right-of-way under the terms and conditions as set forth in the Agreement attached hereto and made a part hereof.

The Business Administrator or his designee is hereby authorized to execute the Revocable License For Fence Encroachment.

\_\_\_\_\_  
Terry Crowley, Jr.,  
Council President

**I HEREBY CERTIFY THAT** the foregoing resolution was duly adopted by the City Council of the City of Ocean City, New Jersey at a Council Meeting held on Thursday, June 11, 2026 with the voting record as indicated below.

NAME	MOTION	SECOND	AYE	NAY	ABSENT	ABSTAINED
Barnes						
Crowley						
Hartzell						
Levchuk						
Madden						
Polcini						
Winslow						

\_\_\_\_\_  
Melissa G. Rasner, City Clerk

## REVOCABLE LICENSE FOR FENCE ENCROACHMENT

Agreement made, effective as of \_\_\_\_\_, 2026, by and between **THE CITY OF OCEAN CITY**, a Municipal Corporation of the State of New Jersey, of 861 Asbury Avenue, Ocean City, NJ 08226 (hereinafter "**City**"), which is the owner of a certain 100' wide right-of-way known as West Avenue; and **PATRICK J. & KAREN FOLEY** and **CHRISTOPHER & SHANNAN KOKOCHA**, whose address is 1229 Orchid Road, Warminster, PA 18974, the owners of 1817 West Avenue (hereinafter collectively "**LICENSEES**").

WITNESSETH:

A. LICENSEES are the owners of Block 1804, Lot 8 situated in the City of Ocean City, County of Cape May and State of New Jersey (hereinafter, the "Property"), and City is the owner of the 100' wide right-of-way known as West Avenue adjacent to the northwesterly side of the Property (see copy of survey prepared by James E. Schwab III, dated April 2, 2003, and marked up by the applicant on or about February 13, 2026, attached hereto as Exhibit A).

B. LICENSEES propose to install a fence in order to enhance the safety of their front yard and would like to install the fence along the adjacent edge of the existing sidewalk, rather than on the property line of the Property.

C. LICENSEES and City desire to create a revocable encroachment license over the area between the property line of the Property and the fence to be constructed by LICENSEES, and permit LICENSEES to install a conforming, open fence along the adjacent edge of the existing sidewalk for the benefit of the Property, subject to the terms and conditions hereinafter set forth.

LICENSEES and City agree as follows:

A revocable license for the proposed a conforming, open fence along the adjacent edge of the existing sidewalk in favor of the LICENSEES' property is created over that portion of the City right-of-way adjacent to Block 1804, Lot 8 and located as depicted on the attached Exhibit A.

This revocable license agreement is specifically intended to and shall run with the land and shall benefit and bind LICENSEES and its successors in title until (a) the fence to be installed in accordance herewith is demolished or removed, after which there shall be no license or other permission for the replacement or reconstruction of any improvements within the public sidewalk, street or right-of-way; or (b) until this revocable license is revoked and extinguished by the City upon 90 days written notice to LICENSEES, or LICENSEES' successor in title, after which the encroachment shall be completely removed and the public right-of-way restored in a manner

consistent with the immediately surrounding area (be it grassed or concrete) at the sole expense of LICENSEES or LICENSEES' successor in title.

LICENSEES shall be responsible for the care and maintenance of the fence. The LICENSEES shall maintain said encroachment in good repair in a neat, safe and orderly fashion, at LICENSEES' sole expense. Similarly, LICENSEES shall indemnify and hold City, its elected officials, employees and agents harmless from any liability of any kind, nature or description, whether with respect to property damage, property repair, personal injury, etc., which may occur as a result of the existence of this revocable license for encroachment, and LICENSEES shall add City as an additional insured on the liability portion of LICENSEES' insurance policy for LICENSEES' premises, as City's interests may appear, as the provider of this revocable license. LICENSEES shall furnish City with a copy of an insurance certificate which complies herewith (or such other form of hold harmless and indemnification as the City Solicitor, in the sound discretion of the City Solicitor, may approve). It shall be LICENSEES' responsibility after full execution of this license to record this license with the Cape May County Clerk's Office and provide a copy of the recorded document to the City.

IN WITNESS WHEREOF, LICENSEES and the City have caused this agreement to be executed, their signatures notarized, and the date of the agreement being set forth as the date of the first to sign, as indicated above, with the completed document and exhibits to then be recorded in the Office of the Cape May County Clerk by LICENSEES.

*SIGNATURE PAGE FOLLOWS*

CITY OF OCEAN CITY, LICENSOR

Attest: \_\_\_\_\_

By: \_\_\_\_\_

STATE OF NEW JERSEY :  
: SS.  
COUNTY OF CAPE MAY :

BE IT REMEMBERED that on this \_\_\_\_\_ day of \_\_\_\_\_, 2026, before me, the subscriber, the undersigned authority, personally appeared **JAY A. GILLIAN, MAYOR** for the CITY OF OCEAN CITY and **MELISSA RASNER, CITY CLERK** for the CITY OF OCEAN CITY, known to me or satisfactorily proven to be the persons who signed the within instrument and acknowledged that they signed, sealed and delivered the same as their voluntary act and deed on behalf of the CITY OF OCEAN CITY for the uses and purposes therein expressed. All of which is hereby certified.

\_\_\_\_\_  
*Notary Public*

\_\_\_\_\_  
PATRICK J. FOLEY, LICENSEE

\_\_\_\_\_  
KAEN FOLEY, LICENSEE

\_\_\_\_\_  
CHRISTOPHER KOKOCHA, LICENSEE

\_\_\_\_\_  
SHANNAN KOKOCHA, LICENSEE

STATE OF NEW JERSEY :  
: SS.  
COUNTY OF CAPE MAY :

BE IT REMEMBERED that on this \_\_\_\_\_ day of \_\_\_\_\_, 2026, before me, the subscriber, the undersigned authority, personally appeared **PATRICK J. FOLEY**, who I am satisfied is the person who signed the within instrument and acknowledged that he signed, sealed and delivered the same as his act and deed for the uses and purposes therein expressed. All of which is hereby certified.

\_\_\_\_\_  
*Notary Public*

STATE OF NEW JERSEY :  
: SS.  
COUNTY OF CAPE MAY :

BE IT REMEMBERED that on this \_\_\_\_\_ day of \_\_\_\_\_, 2026, before me, the subscriber, the undersigned authority, personally appeared **KAREN FOLEY, CHRISTOPHER KOKOCHA, and SHANNAN KOKOCHA** who I am satisfied are the persons who signed the within instrument and acknowledged that they signed, sealed and delivered the same as their act and deed for the uses and purposes therein expressed. All of which is hereby certified.

\_\_\_\_\_  
*Notary Public*



With three different vertical picket sizes to choose from, along with corresponding caps, we offer a wide range of wood picket heritage designs for your Victorian and Classic Series fencing. With inherent endurance and low-maintenance characteristics of vinyl, these traditional fence styles will be a breeze to maintain!

## CLASSIC SERIES



Hawaii - Scalloped Top

Vertical Pickets	7/8" x 3"
Top Rail	2" x 3-1/2"
Bottom Rail	2" x 6" Rail

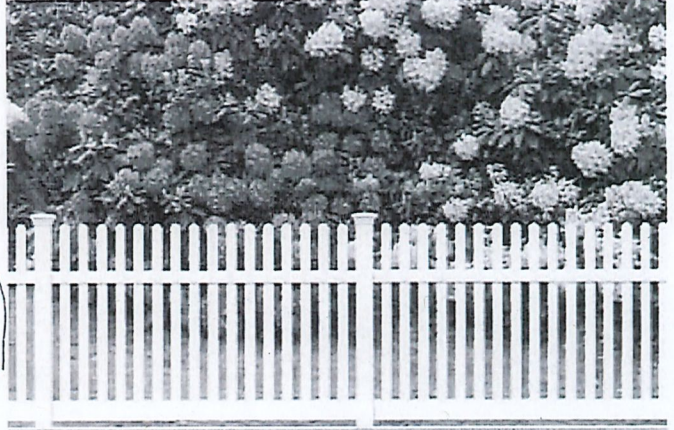

Florida - Straight Top

Vertical Pickets	7/8" x 3"
Top Rail	2" x 3-1/2"
Bottom Rail	2" x 6" Rail

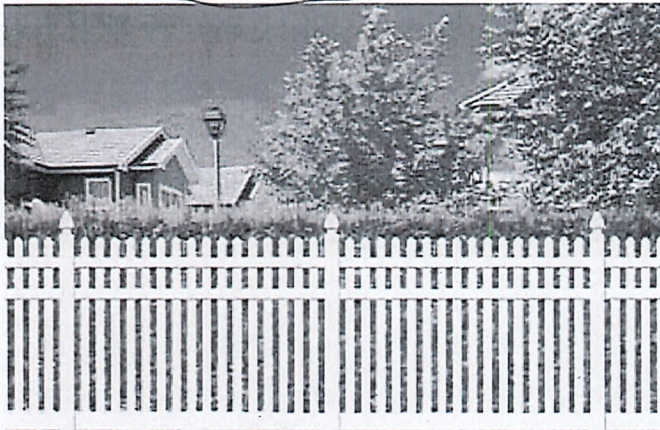

Georgia - 3-Rail Design

Vertical Pickets	7/8" x 3"
Top Rail	2" x 3-1/2"
Bottom Rail	2" x 6" Rail



New Jersey - Pool Style

Vertical Pickets	7/8" x 3"
Top Rail	2" x 3-1/2"
Bottom Rail	2" x 3-1/2" Rail

*Block: 1804 Lot: 8, 1817 West Ave*

P i c k e t F e n c e C a p s

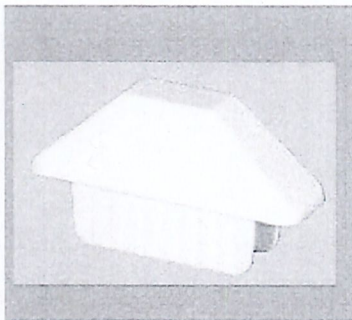

7/8" x 3"  
Utility Picket 7/8" x 3"



7/8" x 3"  
Spade Picket 7/8" x 1-1/2"

**CITY OF OCEAN CITY  
CAPE MAY COUNTY, NEW JERSEY**

**RESOLUTION**

No. 26-162

**APPROVING TAX OVERPAYMENT REFUND  
#2026-5 THRU #2026-7**

WHEREAS, the Tax Collector has certified and issued refund vouchers to the following tax payers who overpaid their taxes.

NOW, THEREFORE BE IT RESOLVED, by the City Council of the City of Ocean City that authorization for refund be approved as per the attached schedule.

**DESCRIPTION**

<u>REFUND#</u>	<u>NAME</u>	<u>BLOCK/LOT/QUAL.</u>	<u>AMOUNT</u>	<u>YEAR</u>
2026-5	CORELOGIC TAX SERVICES	901/1/C405	\$834.91	2026
2026-6	CORELOGIC TAX SERVICES	3304/19/C1	\$1,283.25	2026

**Total            \$2,118.16**

\_\_\_\_\_  
Terry Crowley, Jr.  
Council President

I HEREBY CERTIFY THAT the foregoing resolution was duly adopted by the City Council of the City of Ocean City, New Jersey at a Council Meeting held on Thursday, June 11, 2026, with the voting record as indicated below.

NAME	MOTION	SECOND	AYE	NAY	ABSENT	ABSTAINED
Barnes						
Crowley						
Hartzell						
Levchuk						
Madden						
Polcini						
Winslow						

\_\_\_\_\_  
Melissa G. Rasner, City Clerk



# CITY OF OCEAN CITY

AMERICA'S GREATEST FAMILY RESORT

DIVISION OF TAX COLLECTION

## Memo

**To:** Frank Donato, Director of Financial Management

**From:** Terry Graff, Tax Collector

**Date:** May 18, 2026

**Re:** Refund of Tax Overpayments

Attached, please find a Resolution authorizing refunds of tax overpayments to be placed on the agenda for the City Council meeting of June 11, 2026. The refunds are for overpayments due to the taxpayer for the reasons stated below. Typically, the refunds are for duplicate payments made by the homeowner and a mortgage company or a title company. As you are aware we must apply bulk bank payments in their entirety per a directive from the Division of Local Government Services.

If you have any questions, please contact me.

<u>VOUCHER</u>	<u>NAME</u>	<u>BLOCK/LOT/QUAL.</u>	<u>AMOUNT</u>	<u>REASON</u>
2026-5	CORELOGIC TAX SERVICES	901/1/C405	\$834.91	OVERPAYMENT
2026-6	CORELOGIC TAX SERVICES	3304/19/C1	\$1,283.25	OVERPAYMENT

**Total** **\$2,118.16**

CITY OF OCEAN CITY  
CAPE MAY COUNTY, NEW JERSEY

RESOLUTION

No. 26-163

AMENDING THE 2026 BUDGET OF THE CITY OF OCEAN CITY TO INCLUDE  
ADDITIONAL REVENUE FROM THE UNITED STATES DEPARTMENT OF HOUSING AND  
URBAN DEVELOPMENT, COMMUNITY DEVELOPMENT BLOCK GRANT 2025/26

WHEREAS, N.J.S.A. 40A: 4-87 provides that the Director of the Division of Local Government Services may approve the insertion of any special item of revenue in the budget of any municipality when such item shall have been made available by law and the amount thereof was not determined at the time of the adoption of the budget; and

WHEREAS, said director may also approve the insertion of an item of appropriation for equal amount; and

WHEREAS, the Local share of the above referenced grant is zero; and

NOW, THEREFORE, BE IT RESOLVED that the City of Ocean City hereby requests the Director of the Division of Local Government Services to approve the insertion of an item of revenue in the budget of the year 2026 in the sum of \$269,952.00 which item is now available as a revenue from:

GENERAL REVENUES

Miscellaneous Revenue-Section F  
Special Items of General Revenue Anticipate with  
Prior Written Consent of the Director of Local  
Government Services:  
Public and Private Revenue Offset with Appropriations

U.S. Department of Housing and Urban Development,  
Community Development Block Grant.....\$269,952.00  
pursuant to the provisions of Statute; and

BE IT FURTHER RESOLVED that a like sum of \$269,952.00 be and the same is hereby appropriated under the caption of:

8. GENERAL APPROPRIATIONS

(A) Operations-Excluded from "CAPS"  
Public and Private Programs Offset by Revenues  
U.S. Department of Housing and Urban Development,  
Community Development Block Grant.....\$269,952.00

BE IT FURTHER RESOLVED that a copy of this resolution be certified and submitted electronically to the Director of Local Government Services for approval; and

BE IT FINALLY RESOLVED that this amendment be published on line on June 12, 2026.

Frank Donato III,  
Chief Financial Officer

Terry Crowley, Jr.  
Council President

I HEREBY CERTIFY THAT the foregoing resolution was duly adopted by the City Council of the City of Ocean City, New Jersey at a Council Meeting held on Thursday, June 11, 2026, with the voting record as indicated below.

NAME	MOTION	SECOND	AYE	NAY	ABSENT	ABSTAINED
Barnes						
Crowley						
Hartzell						
Levchuk						
Madden						
Polcini						
Winslow						

Melissa G. Rasner, City Clerk

CITY OF OCEAN CITY  
CAPE MAY COUNTY, NEW JERSEY

RESOLUTION

No. 26-164

AMENDING THE 2026 BUDGET OF THE CITY OF OCEAN CITY TO INCLUDE  
ADDITIONAL REVENUE FROM THE COUNTY OF CAPE MAY,  
“LAND OF THE FREE, CELEBRATION 250”

WHEREAS, N.J.S.A. 40A: 4-87 provides that the Director of the Division of Local Government Services may approve the insertion of any special item of revenue in the budget of any municipality when such item shall have been made available by law and the amount thereof was not determined at the time of the adoption of the budget; and

WHEREAS, said director may also approve the insertion of an item of appropriation for equal amount; and

WHEREAS, the Local share of the above referenced grant is zero; and

NOW, THEREFORE, BE IT RESOLVED that the City of Ocean City hereby requests the Director of the Division of Local Government Services to approve the insertion of an item of revenue in the budget of the year 2026 in the sum of \$25,000.00 which item is now available as a revenue from:

GENERAL REVENUES

Miscellaneous Revenue-Section F  
Special Items of General Revenue Anticipate with  
Prior Written Consent of the Director of Local  
Government Services:

Public and Private Revenue Offset with Appropriations

LAND OF THE FREE, CELEBRATION 250.....\$25,000.00  
pursuant to the provisions of Statute; and

BE IT FURTHER RESOLVED that a like sum of \$25,000.00 be and the same is hereby appropriated under the caption of:

- 8. GENERAL APPROPRIATIONS  
(A) Operations-Excluded from "CAPS"  
Public and Private Programs Offset by Revenues

LAND OF THE FREE, CELEBRATION 250.....\$ 25,000.00  
pursuant to the provisions of Statute; and

BE IT FURTHER RESOLVED that a copy of this resolution be certified and submitted electronically to the Director of Local Government Services for approval; and

BE IT FINALLY RESOLVED that this amendment be published on line on June 12, 2026.

Frank Donato III,  
Chief Financial Officer

Terry Crowley, Jr.  
Council President

I HEREBY CERTIFY THAT the foregoing resolution was duly adopted by the City Council of the City of Ocean City, New Jersey at a Council Meeting held on Thursday, June 11, 2026, with the voting record as indicated below.

NAME	MOTION	SECOND	AYE	NAY	ABSENT	ABSTAINED
Barnes						
Crowley						
Hartzell						
Levchuk						
Madden						
Polcini						
Winslow						

Melissa G. Rasner, City Clerk

CITY OF OCEAN CITY  
CAPE MAY COUNTY, NEW JERSEY

**RESOLUTION**

No. 26-165

**AUTHORIZING THE PAYMENT OF CLAIMS**

**WHEREAS**, N.J.S.A. 40A: 5-17 entitled “Approval and Payment of Claims and Required General Books of Account” generally sets forth the manner in which claims against municipalities are to be handled; and

**WHEREAS**, the attached bill list represents claims against the municipality for period including May 19, 2026 to June 8, 2026

**NOW, THEREFORE, BE IT RESOLVED** that the attached bill list is approved for payment.

\_\_\_\_\_  
Frank Donato III  
Chief Financial Officer

\_\_\_\_\_  
Terry Crowley, Jr.,  
Council President

FILES/AUTHORIZING THE PAYMENT OF CLAIMS – 05.19.26 TO 06.08.26.doc

**I HEREBY CERTIFY THAT** the foregoing resolution was duly adopted by the City Council of the City of Ocean City, New Jersey at a Council Meeting held on Thursday, June 11, 2026 with the voting record as indicated below.

NAME	MOTION	SECOND	AYE	NAY	ABSENT	ABSTAINED
Barnes						
Crowley						
Hartzell						
Levchuk						
Madden						
Polcini						
Winslow						

\_\_\_\_\_  
Melissa G. Rasner, City Clerk

Ranges		Item Status	Purchase Types	Misc				
<i>Range: First to Last</i>		<i>Open: N</i>	<i>Bid: Y</i>		<i>P.O. Type: All</i>			
<i>Rcvd Batch Id Range: First to Last</i>		<i>Void: N</i>	<i>State: Y</i>		<i>Include Project Line Yes</i>			
		<i>Paid: N</i>	<i>Other: Y</i>		<i>Items:</i>			
		<i>Held: Y</i>	<i>Exempt: Y</i>		<i>Format: Condensed</i>			
		<i>Aprv: N</i>			<i>Include Non-Budgeted: Y</i>			
		<i>Rcvd: Y</i>			<i>Vendors: All</i>			
Po #	Po Date	Vendor	Po Description	Status	Amount	Void Amount	Po Type	
23-02828	09/15/23	SOUTHSTA SOUTH STATE, INC.	RESOLUTION #23-60-039	Open	\$9,793.04	\$0.00	B	
24-01146	05/01/24	BLACKVEA BLACK & VEATCH CORPORATIO	RESOLUTION #24-61-001	Open	\$5,813.62	\$0.00	B	
25-00514	02/12/25	CWAHLLC CARLIN, WARD, ASH & HEIART L	Res. 25-61-274	Open	\$13,613.43	\$0.00	B	
25-00679	03/14/25	WEATHRBYWEATHERBY CONSTRUCTION &	RESOLUTION #25-61-301	Open	\$18,710.26	\$0.00	B	
25-02215	08/26/25	TRIAD TRIAD ASSOCIATES		Open	\$37.50	\$0.00		
25-02538	09/15/25	SEASHORESEASHORE ASPHALT CORP.		Open	\$945.28	\$0.00	B	
25-02547	09/19/25	CONCEPTPCONCEPT PRINT	res 25-61-359	Open	\$10,473.85	\$0.00		
25-02956	10/20/25	WITMER WITMER PUBLIC SAFTEY GROU	Res 25-61-234	Open	\$11,418.00	\$0.00		
25-02982	10/23/25	METUC METUCHEN CENTER INC	city bid 25-06	Open	\$1,271.40	\$0.00		
25-02983	10/23/25	METUC METUCHEN CENTER INC	city bid 25-06	Open	\$1,680.20	\$0.00		
25-02984	10/23/25	METUC METUCHEN CENTER INC	city bid 25-06	Open	\$1,931.48	\$0.00		
25-02985	10/23/25	METUC METUCHEN CENTER INC	city bid 25-06 uniforms	Open	\$2,371.25	\$0.00		
25-02986	10/23/25	METUC METUCHEN CENTER INC	city bid 25-06 uniforms	Open	\$1,119.62	\$0.00		
25-02987	10/23/25	METUC METUCHEN CENTER INC	city bid 25-01 uniform	Open	\$702.93	\$0.00		
25-02989	10/23/25	METUC METUCHEN CENTER INC	city bid 25-06 uniforms	Open	\$1,621.04	\$0.00		
25-02990	10/23/25	METUC METUCHEN CENTER INC	city bid 25-06	Open	\$1,650.00	\$0.00		
25-03014	10/29/25	REMINGTO REMINGTON & VERNICK ENGINE	RES NO.25-62-491	Open	\$973.75	\$0.00	B	
25-03052	11/12/25	PAULJBAL PAUL J BALDINI, PA		Open	\$12,344.00	\$0.00		
25-03091	11/13/25	ORIGINAL ORIGINAL WATERMEN, INC.	RESOLUTION #25-61-359	Open	\$16,144.25	\$0.00		
25-03165	11/20/25	SOMERSPCCCITY OF SOMERS POINT		Open	\$2,750.00	\$0.00		
25-03657	12/11/25	MILLESCO MILLENNIUM COMMUNICATIONS	RESOLUTION #25-61-234	Open	\$19,587.12	\$0.00		
26-00021	01/12/26	DELTA DELTA LINE CONSTRUCTION, CC	RESOLUTION #26-06	Open	\$86,894.64	\$0.00		
26-00024	01/12/26	BROWNBR(BROWN & BROWN METRO LLC	RESOLUTION #25-62-439	Open	\$1,618.46	\$0.00		
26-00028	01/12/26	THOMSONFTHOMSON REUTERS		Open	\$442.22	\$0.00		
26-00049	01/15/26	HORIZOND HORIZON BS BC OF NEW JERSE		Open	\$2,459.55	\$0.00		
26-00050	01/15/26	NATIONAL NATIONAL VISION ADMIN, LLC		Open	\$712.16	\$0.00		
26-00051	01/15/26	TRI-STAT TRI-STATE DIAGNOSTICS CORP.		Open	\$4,512.00	\$0.00		
26-00072	01/15/26	ACJIT ATLANTIC CITY JITNEY ASSN.		Open	\$7,780.00	\$0.00		
26-00074	01/15/26	MAINL MAIN LINE COMMERCIAL POOLS		Open	\$1,000.00	\$0.00		
26-00075	01/15/26	LACASCOF LACAS COFFEE COMPANY, LLC		Open	\$1,424.75	\$0.00		
26-00077	01/15/26	THEFLOWE THE FLOWER COMPANY		Open	\$150.00	\$0.00	B	
26-00078	01/15/26	KJPRINTS K J PRINTS		Open	\$1,450.00	\$0.00		
26-00079	01/15/26	CHLORKIN CHLORKING INNOVATIONS, LLC		Open	\$1,595.00	\$0.00		
26-00080	01/15/26	RESTTECH RESTAURANT TECHNOLOGIES I		Open	\$126.37	\$0.00		
26-00081	01/15/26	CAPEENVI CAPE ENVIRONMENTAL TESTIN		Open	\$220.00	\$0.00		
26-00091	01/16/26	06HAR DORIS M. HARTMAN	CONSULTING AND TRAINING	Open	\$126.25	\$0.00		
26-00103	01/21/26	SHOREPHYSHORE PHYSICIANS GROUP	RESOLUTION #26-33	Open	\$480.00	\$0.00		
26-00105	01/21/26	OCFAMILY OC FAMILY MEDICINE	RESOLUTION #26-33	Open	\$2,320.00	\$0.00		
26-00111	01/21/26	SCHEULE SCHEULE PLANNING SOLUTION	2026 PLANNING BOARD - PLANNER	Open	\$200.00	\$0.00		
26-00113	01/21/26	CAPRI CAPRIONI PORTABLE TOILETS, I	RESOLUTION #25-62-470	Open	\$1,600.00	\$0.00		
26-00114	01/21/26	CAPRI CAPRIONI PORTABLE TOILETS, I	RESOLUTION #25-62-470	Open	\$80.00	\$0.00		
26-00115	01/21/26	CAPRI CAPRIONI PORTABLE TOILETS, I	RESOLUTION #25-62-470	Open	\$1,600.00	\$0.00	B	
26-00116	01/21/26	CAPRI CAPRIONI PORTABLE TOILETS, I	RESOLUTION #25-62-470	Open	\$1,600.00	\$0.00		
26-00117	01/21/26	CAPRI CAPRIONI PORTABLE TOILETS, I	RESOLUTION #25-62-470	Open	\$2,250.00	\$0.00		

CITY OF OCEAN CITY  
Bill List By P.O. Number

Po #	Po Date	Vendor	Po Description	Status	Amount	Void Amount	Po Type
26-00119	01/21/26	CAPRI	CAPRIONI PORTABLE TOILETS, I RESOLUTION #25-62-470	Open	\$100.00	\$0.00	
26-00122	01/21/26	CAPRI	CAPRIONI PORTABLE TOILETS, I RESOLUTION #25-62-470	Open	\$1,600.00	\$0.00	B
26-00126	01/21/26	ELDERPES	ELDER PEST CONTROL, INC	Open	\$1,467.00	\$0.00	
26-00139	01/21/26	GEESE	GEESE CHASERS SOUTH JERSE	Open	\$1,299.00	\$0.00	
26-00143	01/21/26	PROFCLEA	PROFESSIONAL CLEANING SER' RESOLUTION #25-62-553	Open	\$26,365.72	\$0.00	
26-00144	01/21/26	COASTALL	COASTAL LANDSCAPING	Open	\$16,169.98	\$0.00	
26-00145	01/21/26	RIGGI	RIGGINS, INC. RESOLUTION #26-17	Open	\$53,488.44	\$0.00	
26-00146	01/21/26	RPM LAND	RPM LANDSCAPE CONTRACTOF RESOLUTION #25-61-280	Open	\$25,051.75	\$0.00	
26-00150	01/21/26	SJOVE	SOUTH JERSEY OVERHEAD DO	Open	\$1,272.00	\$0.00	
26-00151	01/21/26	PINELCON	PINELAND CONSTRUCTION, LLC RES. 22-59-085	Open	\$114,185.79	\$0.00	
26-00152	01/21/26	PINELCON	PINELAND CONSTRUCTION, LLC RES. 22-59-087	Open	\$4,434.87	\$0.00	
26-00154	01/21/26	PINELCON	PINELAND CONSTRUCTION, LLC RES 22-59-086	Open	\$114,185.79	\$0.00	
26-00155	01/21/26	PINELCON	PINELAND CONSTRUCTION, LLC RES 22-59-087	Open	\$10,902.00	\$0.00	
26-00157	01/21/26	PINELCON	PINELAND CONSTRUCTION, LLC RES 22-59-087	Open	\$7,186.62	\$0.00	
26-00158	01/21/26	PINELCON	PINELAND CONSTRUCTION, LLC RES 22-59-087	Open	\$15,909.64	\$0.00	
26-00165	01/22/26	SJGAS	SOUTH JERSEY GAS COMPANY 2026 GAS CHARGES	Open	\$10,413.98	\$0.00	
26-00169	01/22/26	SENTI	SENTINEL LEDGER 2026 SENTINEL LEDGER ADS	Open	\$1,947.00	\$0.00	
26-00172	01/22/26	ACCURATE	ACCURATE LANGUAGE SERVICE	Open	\$180.00	\$0.00	
26-00227	01/29/26	MCNEE	CHARLES MCNEELEY	Open	\$1,541.70	\$0.00	
26-00257	02/03/26	WEBPAGE	WEBPAGEFX, INC	Open	\$27,434.07	\$0.00	
26-00259	02/03/26	DAVIDSHU	DAVID SCHULTZ AIRSHOWS LLC	Open	\$3,000.00	\$0.00	
26-00262	02/03/26	JUSTR	JUST RIGHT TV PRODUCTIONS   Video Taping/City Wide	Open	\$560.00	\$0.00	
26-00266	02/03/26	NJTRS	NJ TRANSIT 2026 BUS & TICKET SALES	Open	\$10,287.78	\$0.00	
26-00272	02/05/26	RUDERM	RUDERMAN & ROTH, LLC RESOLUTION #26-85	Open	\$5,865.00	\$0.00	B
26-00273	02/05/26	BLANEYKA	BLANEY, WEINBERG & CURCIO F RESOLUTION #26-82	Open	\$3,325.00	\$0.00	B
26-00299	02/06/26	LUMBERMAL	LUMBERMEN ASSOCIATES INC RESOLUTION #26-48	Open	\$26,141.50	\$0.00	
26-00415	02/12/26	ENGDAM	ENGINEERING DESIGN ASSOCIA/ 2026 EDA ZB PROFESSIONAL	Open	\$1,821.25	\$0.00	
26-00416	02/12/26	MANOSLLC	MANOS LAW FIRM LLC 2026 ZB SOLICITOR MANOS	Open	\$1,900.00	\$0.00	
26-00447	02/18/26	CAPRC	CAPRI CONSTRUCTION CO., INC	Open	\$34,000.00	\$0.00	
26-00454	02/19/26	SOMERSPC	CITY OF SOMERS POINT	Open	\$4,250.00	\$0.00	
26-00455	02/19/26	SENTI	SENTINEL LEDGER 2025 SENTINEL LEDGER ADS	Open	\$171.50	\$0.00	
26-00542	03/16/26	CLAIRGLO	CLAIR GLOBAL CORPORATION	Open	\$4,088.00	\$0.00	
26-00548	03/16/26	STINE	STINEMAN RIBBON & TROPHY C	Open	\$1,711.44	\$0.00	
26-00563	03/16/26	UNIVERS	UNIVERSAL MEDIA, INC.	Open	\$59,666.91	\$0.00	
26-00638	03/23/26	CANNON15	CANNON USA INC. INSPECT PRIOR TO MAINT AGREEM	Open	\$857.80	\$0.00	
26-00648	03/24/26	DIVALEQU	DIVAL SAFETY EQUIPMENT, INC. Res 25-61-234	Open	\$567.00	\$0.00	
26-00659	03/24/26	FALCONS	EAST COAST FALCONS, LLC RESOLUTION #26-89	Open	\$25,456.08	\$0.00	
26-00669	03/30/26	MUSCO	MUSCO SPORTS LIGHTING, LLC	Open	\$950.00	\$0.00	
26-00684	04/02/26	GLOBALIN	GLOBAL INTERACTIVE SOLUTIO	Open	\$458.76	\$0.00	
26-00689	04/09/26	ACTIONUN	ACTION UNIFORM CO., L.L.C Res 24-60-286	Open	\$5,223.00	\$0.00	
26-00707	04/14/26	PROFCLEA	PROFESSIONAL CLEANING SER' CITY CONTRACT 26-04	Open	\$56,177.71	\$0.00	B
26-00711	04/15/26	UPINCODE	UP IN CODE INC	Open	\$1,717.65	\$0.00	
26-00722	04/16/26	DEVLN	EDMUND F.X. DEVLIN, ESQ. RESOLUTION #26-84	Open	\$3,626.06	\$0.00	
26-00731	04/20/26	BAYSIDEC	BAYSIDE CONSTRUCTION SER.,	Open	\$15,500.00	\$0.00	
26-00740	04/24/26	ACTIO	ACTION SUPPLY, INC.	Open	\$2,112.35	\$0.00	
26-00741	04/24/26	GAME	GAME-TIME	Open	\$850.84	\$0.00	
26-00742	04/24/26	Y-PERS	Y-PERS INC	Open	\$658.00	\$0.00	
26-00746	04/24/26	GLOUC	GLOUCESTER COUNTY POLICE	Open	\$450.00	\$0.00	

Po #	Po Date	Vendor	Po Description	Status	Amount	Void Amount	Po Type
26-00748	04/24/26	DEPT DEPTCOR	TAX COLLECTION ENVELOPES 30K	Open	\$2,160.00	\$0.00	
26-00749	04/24/26	IFP THE INSTITUTE FOR FORENSIC		Open	\$3,425.00	\$0.00	
26-00754	04/29/26	ELLIOTJR JOHN R. ELLIOT FOUNDATION		Open	\$10,000.00	\$0.00	
26-00755	04/29/26	TAMCOCONTAMCO CONSTRUCTION INC.	RESOLUTION #26-116	Open	\$208,800.00	\$0.00	B
26-00871	05/01/26	ALWAYSAD ALWAYS ADVANCING	RESOLUTION #25-61-363	Open	\$5,675.00	\$0.00	
26-00873	05/01/26	DEPT DEPTCOR	RESOLUTION #26-17	Open	\$72.00	\$0.00	
26-00902	05/04/26	BUDS BUD'S OUTBOARD MARINE, INC.		Open	\$546.60	\$0.00	
26-00906	05/05/26	PIONEERC PIONEER PIPE CONTRACTORS I		Open	\$25,750.00	\$0.00	
26-00909	05/05/26	FASTSURF FAST SURFACES		Open	\$46,475.00	\$0.00	
26-00911	05/07/26	MESMUNIC MUNICIPAL EMERGENCY SERVI	Res 25-61-234	Open	\$2,521.94	\$0.00	
26-00912	05/07/26	ACTIONUN ACTION UNIFORM CO., L.L.C	Res 25-62-385	Open	\$1,529.00	\$0.00	
26-00913	05/07/26	SULLIVJE JEREMY SULLIVAN		Open	\$250.00	\$0.00	
26-00914	05/07/26	ACTIONUN ACTION UNIFORM CO., L.L.C	Res 25-62-385	Open	\$864.00	\$0.00	
26-00915	05/07/26	TECHNICA TECHNICAL FIRE SERVICES, INC	ANNUAL PUMPER TESTING	Open	\$2,800.00	\$0.00	
26-00916	05/07/26	WATERWAYWATERWAY TWIN TIER LLC	ANNUAL HOSE TESTING	Open	\$6,128.20	\$0.00	
26-00918	05/07/26	SOUTJ SOUTH JERSEY WELDING SUPP	MEDICAL OXYGEN	Open	\$2,156.00	\$0.00	
26-00919	05/07/26	GEMINGEN GEMINI GENERAL CONTRACTIN		Open	\$25,200.00	\$0.00	
26-00920	05/07/26	GSGROUNDGARDEN STATE GROUNDS CON		Open	\$6,500.00	\$0.00	
26-00922	05/07/26	JAMESPLO JAMES PLOURDE PAINTING		Open	\$3,000.00	\$0.00	
26-00923	05/07/26	RALPH V.E. RALPH, INC.	Res 25-61-230	Open	\$4,495.40	\$0.00	B
26-00927	05/11/26	THOMASMI THOMAS G.SMITH, ESQ.	RESOLUTION #26-31	Open	\$12,122.32	\$0.00	
26-00929	05/12/26	SENIOREX SENIOR EXCURSIONS INC	Chicago Play day trip final	Open	\$6,050.00	\$0.00	
26-00932	05/12/26	TEIT TEITLER & TEITLER, LLC	COMPLAINT NO. S-2025-000298	Open	\$300.00	\$0.00	
26-00937	05/12/26	WALTERS R.A. WALTERS & SON, INC.	Emergent Condition	Open	\$27,200.00	\$0.00	
26-00940	05/15/26	JPCOOKEC J P COOKE COMPANY	2027 Dog tags	Open	\$382.15	\$0.00	
26-01018	05/15/26	LEHMANEL ELIZABETH F. LEHMAN	MAY ELECTION POLL WORKER	Open	\$300.00	\$0.00	
26-01032	05/18/26	01CORELO CORELOGIC TAX SERVICES	TAX OVERPAYMENT REFUND#2026	Open	\$834.91	\$0.00	
26-01033	05/18/26	01CORELO CORELOGIC TAX SERVICES	TAX OVERPAYMENT REFUND#2026	Open	\$1,283.25	\$0.00	
26-01035	05/18/26	A2ZEMBLE A2Z EMBLEMS		Open	\$850.00	\$0.00	
26-01037	05/18/26	TRIAD TRIAD ASSOCIATES	RESOLUTION #25-62-469	Open	\$5,500.00	\$0.00	B
26-01043	05/19/26	COASM COASTAL MARINE PILING, INC		Open	\$4,600.00	\$0.00	
26-01044	05/19/26	EASTS EASTERN SIGN CO		Open	\$1,490.00	\$0.00	
26-01048	05/19/26	824ATLAN 824 ATLANTIC AVENUE LLC	REFUND ESCROW 824 ATLANTIC A	Open	\$273.50	\$0.00	
26-01050	05/20/26	MISSIONC MISSION COMMUNICATIONS LLC		Open	\$3,943.80	\$0.00	
26-01051	05/20/26	ELTRU EASTERN LIFT TRUCK, INC.		Open	\$375.00	\$0.00	
26-01052	05/20/26	CENTRALA CENTRAL AVENUE ALLEYOOP LI	REFUND ESCROW 400 47TH STREE	Open	\$364.46	\$0.00	
26-01053	05/20/26	CENTRALA CENTRAL AVENUE ALLEYOOP LI	REFUND ESCROW 130 & 136 WEST	Open	\$92.83	\$0.00	
26-01054	05/20/26	JWR CONS JWR PROPERTIES INC.	REFUND ESCROW106 E. 12TH ST	Open	\$605.60	\$0.00	
26-01055	05/20/26	SECARE SECARE LAW FIRM	DIDCIPLINARY HEARING MILLEVOI	Open	\$2,774.00	\$0.00	
26-01057	05/22/26	EMSAR EMSAR NEW JERSEY		Open	\$541.30	\$0.00	
26-01058	05/22/26	KEAVNEY KEAVNEY & STREGER LLC		Open	\$280.00	\$0.00	
26-01059	05/22/26	RALPH V.E. RALPH, INC.	Res 25-61-230	Open	\$1,835.00	\$0.00	
26-01060	05/22/26	ACTIONUN ACTION UNIFORM CO., L.L.C	Res 24-60-286	Open	\$185.00	\$0.00	
26-01061	05/22/26	DIVALEQU DIVAL SAFETY EQUIPMENT, INC.	Res 25-61-234	Open	\$814.00	\$0.00	
26-01062	05/22/26	DUO-S DUO-SAFETY LADDER CORPOR.		Open	\$214.46	\$0.00	
26-01063	05/22/26	ACTIONUN ACTION UNIFORM CO., L.L.C	Res 24-60-286	Open	\$181.00	\$0.00	
26-01065	05/22/26	NJJUV N.J. JUVENILE OFFICERS ASSN.		Open	\$250.00	\$0.00	
26-01066	05/22/26	ACCURATE ACCURATE LANGUAGE SERVICE		Open	\$240.00	\$0.00	

Po #	Po Date	Vendor	Po Description	Status	Amount	Void Amount	Po Type
26-01067	05/22/26	SCHOP	WILLIAM SCHOPPY TROPHY CO	Open	\$15.99	\$0.00	
26-01069	05/22/26	ACTIONUN	ACTION UNIFORM CO., L.L.C Res 24-60-286	Open	\$445.00	\$0.00	
26-01072	05/22/26	IFP	THE INSTITUTE FOR FORENSIC	Open	\$2,850.00	\$0.00	
26-01073	05/22/26	ACTIONUN	ACTION UNIFORM CO., L.L.C	Open	\$430.00	\$0.00	
26-01074	05/22/26	SCHULKIB	BRUCE JOSEPH SCHULKINS May 2026 Election Poll Worker	Open	\$300.00	\$0.00	
26-01203	05/27/26	INSTITUT	INSTITUTE FOR FORENSIC	Open	\$3,000.00	\$0.00	
26-01204	05/27/26	INSTITUT	INSTITUTE FOR FORENSIC	Open	\$1,725.00	\$0.00	
26-01205	05/27/26	NJDAE	N.J. DIVISION OF AERONAUTICS AIRPORT AERONAUTICAL LIC 2026	Open	\$35.00	\$0.00	
26-01206	05/27/26	CUMMA	CUMMINS-ALLISON CORPORATI METER COIN COUNTER SVC. AGM	Open	\$1,104.00	\$0.00	
26-01207	05/28/26	BANKSJ	JAMES BANKS	Open	\$221.85	\$0.00	
26-01209	05/28/26	OCHUM	OCEAN CITY HUMANE SOCIETY 2025 ALLOTMENT RES#24-61-198	Open	\$92,185.00	\$0.00	
26-01215	05/29/26	CRAIGJ	JAMES CRAIG	Open	\$85.25	\$0.00	
26-01216	05/29/26	ACHRISTA	ACHRISTAVEST BUILDERS LLC REFUND ESCROW 1357 ASBURY A	Open	\$785.80	\$0.00	
26-01217	05/29/26	DIVLGS	DIVISION OF LOCAL GOVT SERV T.GRAFF - CTC RENEWAL #T-8141	Open	\$50.00	\$0.00	
26-01218	05/29/26	BENDERST	STACY BENDER	Open	\$20.00	\$0.00	
26-01225	06/01/26	PLYLERPR	PLYLER PREMIUM	Open	\$1,029.09	\$0.00	
26-01227	06/01/26	JNEWMAN	JOSHUA NEWMAN	Open	\$161.75	\$0.00	
26-01228	06/01/26	OGULEA	AUSTIN OGULE	Open	\$244.49	\$0.00	
26-01229	06/01/26	ACTIONUN	ACTION UNIFORM CO., L.L.C	Open	\$368.00	\$0.00	
26-01230	06/01/26	ATLANTAC	ATLANTIC TACTICAL, LLC	Open	\$299.60	\$0.00	
26-01231	06/01/26	DIVCR	DIVISION OF CRIMINAL JUSTICE	Open	\$1,000.00	\$0.00	
26-01232	06/01/26	ACTIONUN	ACTION UNIFORM CO., L.L.C	Open	\$185.00	\$0.00	
26-01233	06/01/26	WHALEBBU	WHALE BEACH BUILDERS LLC REFUND ESCROW 810 ST JAMES P	Open	\$598.00	\$0.00	
26-01235	06/01/26	KARDASP	PETE KARDAS	Open	\$258.63	\$0.00	
26-01236	06/01/26	HIGHBCBS	HIGHMARK BCBS DELAWARE	Open	\$106.06	\$0.00	
26-01237	06/01/26	ASSENMACPAT	ASSENMACHER	Open	\$30.00	\$0.00	
26-01240	06/03/26	MUNICAPI	MUNICIPAL CAPITAL FINANCE COPIER LEASE RES# 22-58-236	Open	\$32,500.35	\$0.00	
26-01247	06/03/26	REAGANEL	REAGAN ELECTRIC LLC	Open	\$5,750.63	\$0.00	
26-01248	06/03/26	LEHMANJO	JOSEPH LEHMAN SR May 2026 Election Judge	Open	\$325.00	\$0.00	
26-01249	06/03/26	FOLKESDA	DANIEL FOLKES REFUND ESCROW 5116-18 HAVEN /	Open	\$430.00	\$0.00	
26-01251	06/03/26	OCEAN900	OCEAN ISLE 900 MOTEL CONDO REFUND ESCROW 900 OCEAN AVE	Open	\$187.50	\$0.00	
26-01252	06/03/26	WMULLRAY	WILLIAM MULLRAY	Open	\$258.27	\$0.00	
26-01253	06/03/26	CWAHLLC	CARLIN, WARD, ASH & HEIART L Res. 26-83	Open	\$19,183.07	\$0.00	B
26-01254	06/03/26	PICKERIN	MAUREEN PICKERING 2026 June Primary Election	Open	\$325.00	\$0.00	
26-01255	06/03/26	WINSLOWK	KATHLEEN F. WINSLOW 2026 June Primary Election	Open	\$325.00	\$0.00	
26-01256	06/03/26	SOUTARG	GEORGE P. SOUTAR 2026 June Primary Election	Open	\$325.00	\$0.00	
26-01257	06/03/26	TURNERC	CLARA TURNER 2026 JUNE PRIMARY ELECTION	Open	\$325.00	\$0.00	
26-01258	06/03/26	25CIO	JOANN CIOETA 2026 JUNE PRIMARY ELECTION	Open	\$325.00	\$0.00	
26-01259	06/03/26	BUKERR	ROBERT L. BUKER 2026 JUNE PRIMARY ELECTION	Open	\$325.00	\$0.00	
26-01260	06/03/26	CRITCHF	FRANCES CRITCH 2026 JUNE PRIMARY ELECTION	Open	\$325.00	\$0.00	
26-01261	06/03/26	ORGOVANG	GERALD W. ORGOVAN 2026 JUNE PRIMARY ELECTION	Open	\$325.00	\$0.00	
26-01262	06/03/26	KERRYTRE	KERRY TREASURE 2026 JUNE PRIMARY ELECTION	Open	\$325.00	\$0.00	
26-01263	06/03/26	POINSETT	BETH ANN POINSETT 2026 JUNE PRIMARY ELECTION	Open	\$325.00	\$0.00	
26-01264	06/03/26	CANDYC	CAROLE M. CANDY 2026 JUNE PRIMARY ELECTION	Open	\$325.00	\$0.00	
26-01265	06/03/26	SGALLATA	FILOMENA M. SGALLATA 2026 JUNE PRIMARY ELECTION	Open	\$325.00	\$0.00	
26-01266	06/03/26	HILLMANN	NANCY LOUISE HILLMAN 2026 JUNE PRIMARY ELECTION	Open	\$325.00	\$0.00	
26-01267	06/03/26	ROBERTD	ROBERT F. DOUGHERTY 2026 JUNE PRIMARY ELECTION	Open	\$325.00	\$0.00	
26-01268	06/03/26	TWEEDD	DEBBIE L. TWEED 2026 JUNE PRIMARY ELECTION	Open	\$325.00	\$0.00	

Po #	Po Date	Vendor	Po Description	Status	Amount	Void Amount	Po Type
26-01269	06/03/26	STRABUKH HENRY W. STRABUK JR	2026 JUNE PRIMARY ELECTION	Open	\$325.00	\$0.00	
26-01270	06/03/26	PASTERNA BETH M. PASTERNAK	2026 JUNE PRIMARY ELECTION	Open	\$325.00	\$0.00	
26-01271	06/03/26	LEHMANJO JOSEPH LEHMAN SR	2026 JUNE PRIMARY ELECTION	Open	\$325.00	\$0.00	
26-01272	06/03/26	MCBRIDEN NOREEN C. MCBRIDE	2026 JUNE PRIMARY ELECTION	Open	\$325.00	\$0.00	
26-01273	06/03/26	JORGE JORGE L. CONSTANTINO	2026 JUNE PRIMARY ELECTION	Open	\$325.00	\$0.00	
26-01274	06/03/26	HAMERL LORA HAMER	2026 JUNE PRIMARY ELECTION	Open	\$300.00	\$0.00	
26-01275	06/03/26	KETTELL LORETTA C. KETTELL	2026 JUNE PRIMARY ELECTION	Open	\$300.00	\$0.00	
26-01276	06/03/26	NACLERIO DORETHA A. NACLERIO	2026 JUNE PRIMARY ELECTION	Open	\$300.00	\$0.00	
26-01277	06/03/26	SULLIVVI VIRGINIA C SULLIVAN	2026 JUNE PRIMARY ELECTION	Open	\$300.00	\$0.00	
26-01278	06/03/26	KRAUSSA ALETA M. KRAUSS (CONNER)	2026 JUNE PRIMARY ELECTION	Open	\$300.00	\$0.00	
26-01279	06/03/26	MCRAET TAMMI DENISE MCRAE	2026 JUNE PRIMARY ELECTION	Open	\$300.00	\$0.00	
26-01280	06/03/26	RANKINS STEPHANIE RANKIN	2026 JUNE PRIMARY ELECTION	Open	\$300.00	\$0.00	
26-01281	06/03/26	CRANEM MARY CRANE	2026 JUNE PRIMARY ELECTION	Open	\$300.00	\$0.00	
26-01282	06/03/26	MCCORMACMAUREEN MCCORMAC	2026 JUNE PRIMARY ELECTION	Open	\$300.00	\$0.00	
26-01283	06/03/26	MINNERC CATHERINE M. MINNER	2026 JUNE PRIMARY ELECTION	Open	\$300.00	\$0.00	
26-01284	06/03/26	ALESZCZY LOUISE A ALEXZCZYK	2026 JUNE PRIMARY ELECTION	Open	\$300.00	\$0.00	
26-01285	06/03/26	AUNGSTE EDWIN B. AUNGST JR.	2026 JUNE PRIMARY ELECTION	Open	\$300.00	\$0.00	
26-01286	06/03/26	CONNORREREBECCA A. CONNOR	2026 JUNE PRIMARY ELECTION	Open	\$300.00	\$0.00	
26-01287	06/03/26	CORCORDDONNA CORCORAN	2026 JUNE PRIMARY ELECTION	Open	\$300.00	\$0.00	
26-01288	06/03/26	HOCKERRCROSEMARY T. HOCKER	2026 JUNE PRIMARY ELECTION	Open	\$300.00	\$0.00	
26-01289	06/03/26	BOLAND CAROL BOLAND	2026 JUNE PRIMARY ELECTION	Open	\$300.00	\$0.00	
26-01290	06/03/26	CONNORW WILDA CONNOR	2026 JUNE PRIMARY ELECTION	Open	\$300.00	\$0.00	
26-01291	06/03/26	DANIELV VICTOR E. DANIEL	2026 JUNE PRIMARY ELECTION	Open	\$300.00	\$0.00	
26-01292	06/03/26	HANOVERK KENNETH HANOVER	2026 JUNE PRIMARY ELECTION	Open	\$300.00	\$0.00	
26-01293	06/03/26	WATTSS SHIRLEY N. WATTS	2026 JUNE PRIMARY ELECTION	Open	\$300.00	\$0.00	
26-01294	06/03/26	WIRTHKAR KARL WIRTH	2026 JUNE PRIMARY ELECTION	Open	\$300.00	\$0.00	
26-01295	06/03/26	BELLWOA RICHARD J. BELLWOAR SR.	2026 JUNE PRIMARY ELECTION	Open	\$300.00	\$0.00	
26-01296	06/03/26	CRITCHF FRANCES CRITCH	2026 JUNE PRIMARY ELECTION	Open	\$300.00	\$0.00	
26-01297	06/03/26	DIVITOS SUZANNE DIVITO	2026 JUNE PRIMARY ELECTION	Open	\$300.00	\$0.00	
26-01298	06/03/26	PARRISHK KEITH B. PARRISH	2026 JUNE PRIMARY ELECTION	Open	\$300.00	\$0.00	
26-01299	06/03/26	JOSEPHC JOSEPH M. CARROLL JR.	2026 JUNE PRIMARY ELECTION	Open	\$300.00	\$0.00	
26-01300	06/03/26	MYERSK KEVIN L. MYERS	2026 JUNE PRIMARY ELECTION	Open	\$300.00	\$0.00	
26-01302	06/03/26	HOCKERED EDWARD L. HOCKER	2026 JUNE PRIMARY ELECTION	Open	\$300.00	\$0.00	
26-01303	06/03/26	TIGHRENE RENEE TIGHE	2026 JUNE PRIMARY ELECTION	Open	\$300.00	\$0.00	
26-01304	06/03/26	CHAPMANPPATRICIA CHAPMAN	2026 JUNE PRIMARY ELECTION	Open	\$300.00	\$0.00	
26-01305	06/03/26	DUCAF FRANK DUCA	2026 JUNE PRIMARY ELECTION	Open	\$300.00	\$0.00	
26-01306	06/03/26	GEHRINGM MICHELE GEHRING	2026 JUNE PRIMARY ELECTION	Open	\$300.00	\$0.00	
26-01307	06/03/26	WALDRONK KATHLEEN B. WALDRON	2026 JUNE PRIMARY ELECTION	Open	\$300.00	\$0.00	
26-01308	06/03/26	AUNGSTB BRENDA V. AUNGST	2026 JUNE PRIMARY ELECTION	Open	\$300.00	\$0.00	
26-01309	06/03/26	WEBERJ JOANNE M. WEBER	2026 JUNE PRIMARY ELECTION	Open	\$300.00	\$0.00	
26-01310	06/03/26	DANGELOP PATRICIA DANVELO	2026 JUNE PRIMARY ELECTION	Open	\$300.00	\$0.00	
26-01311	06/03/26	POWELLD DAVID E. POWELL	2026 JUNE PRIMARY ELECTION	Open	\$300.00	\$0.00	
26-01312	06/03/26	SARINJ JOHN SARIN	2026 JUNE PRIMARY ELECTION	Open	\$300.00	\$0.00	
26-01313	06/03/26	JUNEANTO JUNE ANTONELLI - GLACE	2026 JUNE PRIMARY ELECTION	Open	\$300.00	\$0.00	
26-01314	06/03/26	GENOVESG GERALDINE A. GENOVESE	2026 JUNE PRIMARY ELECTION	Open	\$300.00	\$0.00	
26-01315	06/03/26	WILSONCH CHRISTINE WILSON	2026 JUNE PRIMARY ELECTION	Open	\$300.00	\$0.00	
26-01316	06/03/26	CANTARAMM MARGARET CANTARA	2026 JUNE PRIMARY ELECTION	Open	\$300.00	\$0.00	
26-01317	06/03/26	ROCKEYW WALTER A. ROCKEY III	2026 JUNE PRIMARY ELECTION	Open	\$300.00	\$0.00	

Po #	Po Date	Vendor	Po Description	Status	Amount	Void Amount	Po Type
26-01318	06/03/26	STRICOFF LOUIS STRICOFF	2026 JUNE PRIMARY ELECTION	Open	\$300.00	\$0.00	
26-01319	06/03/26	DORIAL LAURA M. DORIA	2026 JUNE PRIMARY ELECTION	Open	\$300.00	\$0.00	
26-01320	06/03/26	LEHMANEL ELIZABETH F. LEHMAN	2026 JUNE PRIMARY ELECTION	Open	\$300.00	\$0.00	
26-01321	06/03/26	MCNEILLN NANCY MCNEILL	2026 JUNE PRIMARY ELECTION	Open	\$300.00	\$0.00	
26-01322	06/03/26	CHAPMANTTHOMAS A. CHAPMAN	2026 JUNE PRIMARY ELECTION	Open	\$300.00	\$0.00	
26-01323	06/03/26	CLARKMARMARGUERITE S. CLARK	2026 JUNE PRIMARY ELECTION	Open	\$300.00	\$0.00	
26-01324	06/03/26	CRISTOFA THERESA R. CRISTOFARO	2026 JUNE PRIMARY ELECTION	Open	\$300.00	\$0.00	
26-01325	06/03/26	LYONS I INGRID LYONS	2026 JUNE PRIMARY ELECTION	Open	\$300.00	\$0.00	
26-01326	06/03/26	MESSINAA ANITA MESSINA	2026 JUNE PRIMARY ELECTION	Open	\$300.00	\$0.00	
26-01327	06/03/26	LEHNL LINDA J. LEHN	2026 JUNE PRIMARY ELECTION	Open	\$300.00	\$0.00	
26-01328	06/03/26	MASTROCCCHRISTINE MASTROCOLA	2026 JUNE PRIMARY ELECTION	Open	\$300.00	\$0.00	
26-01329	06/03/26	MASTAOCOMICHAEL MASTROCOLA	2026 JUNE PRIMARY ELECTION	Open	\$300.00	\$0.00	
26-01330	06/03/26	ROCKEYG GAILE ROCKEY	2026 JUNE PRIMARY ELECTION	Open	\$300.00	\$0.00	
26-01331	06/03/26	WALDRONJJOHN R. WALDRON JR.	2026 JUNE PRIMARY ELECTION	Open	\$300.00	\$0.00	
26-01332	06/03/26	AME AMERICAN LEGION	POLLING LOCATION JUNE 2026	Open	\$75.00	\$0.00	
26-01333	06/03/26	HAINESGE GEORGE HAINES	RELEASE OF PERFORMANCE	Open	\$6,261.60	\$0.00	
26-01334	06/04/26	SAINTFRA SAINT FRANCIS CABRINI CHURC	POLLING LOCATION PRIMARY 2026	Open	\$75.00	\$0.00	
26-01335	06/04/26	OCFRE OCEAN CITY FREE PUBLIC LIBR.	POLLING LOCATION PRIMARY 2026	Open	\$75.00	\$0.00	
26-01336	06/04/26	OCYAC OCEAN CITY YACHT CLUB	POLLING LOCATION PRIMARY 2026	Open	\$75.00	\$0.00	
26-01337	06/04/26	6THSTREE 6TH STREET CIVIC CENTER	POLLING LOCATION PRIMARY 2026	Open	\$75.00	\$0.00	
26-01338	06/04/26	8THSTREE 8th STREET REC CENTER	POLLING LOCATION PRIMARY 2026	Open	\$75.00	\$0.00	
26-01339	06/04/26	SCHULKIB BRUCE JOSEPH SCHULKINS	JUNE PRIMARY ELECTION 2026	Open	\$300.00	\$0.00	
26-01342	06/05/26	74CAB WILLIAM CAMPBELL		Open	\$252.97	\$0.00	
26-01343	06/05/26	MARYBETHMARY BETH SNOW'S DANCE PL		Open	\$40,176.00	\$0.00	
26-01344	06/05/26	NANTU NANTUCKET CONDOMINIUM AS: REFUND ESCROW 2702 2		Open	\$3,906.35	\$0.00	
26-01345	06/05/26	THOMSUSATHOMAS & SUSAN MITCHELL	REFUND ESCROW 40 BAY AVENUE	Open	\$76.50	\$0.00	

<b>Total Purchase Orders:</b>	<b>262</b>	<b>Total P.O. Line Items:</b>	<b>0</b>	<b>Total List Amount:</b>	<b>\$1,635,544.87</b>	<b>Total Void Amount:</b>	<b>\$0.00</b>
-------------------------------	------------	-------------------------------	----------	---------------------------	-----------------------	---------------------------	---------------

Totals by Year-Fund							
Fund Description	Fund	Budget Rcvd	Budget Held	Budget Total	Revenue Total	G/L Total	Project Total
	5-01	\$70,418.70	\$0.00	\$70,418.70	\$0.00	\$0.00	\$0.00
	6-01	\$775,074.62	\$0.00	\$775,074.62	\$10,443.84	\$0.00	\$0.00
	6-12	\$0.00	\$0.00	\$0.00	\$0.00	\$0.00	\$11,241.79
	6-13	\$87,122.48	\$0.00	\$87,122.48	\$0.00	\$0.00	\$0.00
	Year Total:	\$862,197.10	\$0.00	\$862,197.10	\$10,443.84	\$0.00	\$11,241.79
	C-04	\$582,480.15	\$0.00	\$582,480.15	\$0.00	\$0.00	\$0.00
	G-02	\$40,474.92	\$0.00	\$40,474.92	\$0.00	\$0.00	\$0.00
	T-12	\$58,288.37	\$0.00	\$58,288.37	\$0.00	\$0.00	\$0.00
<b>Total Of All Funds:</b>		<b>\$1,613,859.24</b>	<b>\$0.00</b>	<b>\$1,613,859.24</b>	<b>\$10,443.84</b>	<b>\$0.00</b>	<b>\$11,241.79</b>

Project Description	Project No.	Rcvd Total
400 47TH STREET	21-018IPBA	\$364.46
1357 ASBURY AVENUE	21-019IPBA	\$785.80
824 ATLANTIC AVENUE	21-024IPBA	\$273.50
106 12TH STREET	22-007IPBA	\$605.60
130& 136 WEST AVENUE	22-010IPBA	\$92.83
900 OCEAN AVENUE	22-015PBA	\$187.50
SCONSET/FOLGER COURT	22-036PBA	\$3,906.35
2308-10 WESLEY AVENUE	24-005ZBA	\$116.25
40 BAY AVENUE	24-006ZBA	\$76.50
5116-18 HAVEN AVENUE	25-001ZBA	\$430.00
810 ST JAMES PLACE	25-002ZBA	\$598.00
112 SIXTH STREET	25-010PBA	\$200.00
1168 BOARDWALK	25-016ZBA	\$77.50
1833-35 WESLEY AVENUE	26-001ZBA	\$155.00
2904-06 WESLEY AVENUE	26-002ZBA	\$77.50
621 BATTERSEA ROAD	26-003ZBA	\$550.00
304 SEABRIGHT ROAD	26-004ZBA	\$150.00
141-47 HAVEN AVENUE	26-005ZBA	\$930.00
316 E INLET ROAD	26-006ZBA	\$1,015.00
3300-02 & 3304-06 SIMPSON AVE	26-007ZBA	\$50.00
3323 SIMPSON AVENUE	26-008ZBA	\$150.00
21 NAUSSAU ROAD	26-009ZBA	\$200.00
3829-31 CENTRAL AVENUE	26-010ZBA	\$150.00
3829-31 CENTRAL AVENUE	26-011ZBA	\$100.00
Total Of All Projects:		\$11,241.79