



# CITY OF CRESCENT CITY

MAYOR ISAIAH WRIGHT  
COUNCIL MEMBER RAY ALTMAN  
COUNCIL MEMBER STEVE SHAMBLIN

MAYOR PRO TEM CANDACE TINKLER  
COUNCIL MEMBER JASON GREENOUGH

**AGENDA**  
**REGULAR MEETING OF THE**  
**CITY COUNCIL OF THE CITY OF CRESCENT CITY**  
FLYNN CENTER BOARD CHAMBERS  
981 H STREET  
CRESCENT CITY, CA 95531

**MONDAY**

**APRIL 20, 2026**

**6:00 P.M.**

**This meeting will be held in person at the location listed above.** The City will broadcast the meeting on YouTube, however, if there is a technological issue with YouTube, the meeting will continue in person as scheduled. The public may access and participate in the public meeting by (1) attending the meeting in person and making public comment when called for by the Mayor or (2) by submitting a written comment via [publiccomment@crecentcity.org](mailto:publiccomment@crecentcity.org) or by filing it with the City Clerk at 377 J Street, Crescent City, California, 95531. All public comments (via email or mail) must be received by the City Clerk prior to 12:00 p.m. the day of the meeting. Please identify the meeting date and agenda item to which your comment pertains in the subject line. Public comments so received will be forwarded to the City Council and posted on the website next to the agenda. **Written public comments will not be read aloud during the meeting.**

*Notice regarding Americans with Disabilities Act:* In compliance with the Americans with Disabilities Act, if you need special assistance to participate in the meeting, please contact the City Clerk's office at (707)464-7483, ext. 12. Notification 48 hours before the meeting will enable the City to make reasonable arrangements to ensure accessibility to this meeting [28 CFR 35.102-35.104 ADA Title II]. For TTYDD use for speech and hearing impaired, please dial 711. A full agenda packet may be reviewed at City Hall, 377 J Street, Crescent City, CA or on our website: [www.crescentcity.org](http://www.crescentcity.org)

## **OPEN SESSION**

**Call to order**  
**Roll call**  
**Pledge of Allegiance**

**CEREMONIAL ITEMS - None**

**REPORTS AND PRESENTATIONS - None**

## **PUBLIC COMMENT PERIOD**

*Any member of the audience is invited to address the City Council on any matter that is within the jurisdiction of the City of Crescent City. Comments of public interest or on matters appearing on the agenda are accepted. Note, however, that the Council is not able to undertake extended discussion or act on non-agendized items. Such items can be referred to staff for appropriate action, which may include placement on a future agenda. All comments shall be directed toward the entire Council. Any comments that are not at the podium are out of order and will not be a part of the public record. After receiving recognition from the Mayor, please state your name and city or county residency for the record. Public comment is limited to three (3) minutes. The public is additionally allotted three minutes each in which to speak on any item on the agenda prior to any action taken by the Council.*

## **CONSENT CALENDAR**

The consent calendar contains items deemed to be non-controversial and routine in nature. All items on the consent calendar will be considered as a block and voted upon in one vote unless a member of the City Council “pulls” an item from consent for individual consideration. Public comment will be taken on the consent agenda as a whole, unless an item is pulled. Any pulled item will receive its own public comment opportunity.

### **1. Warrant Claims List**

- *Recommendation: Receive and file the warrant claims list for the period March 21, 2026 through April 3, 2026.*

### **2. Council Minutes**

- *Recommendation: Approve and adopt the April 6, 2026 minutes of the City Council of the City of Crescent City.*

### **3. Payroll Report**

- *Recommendation: Receive and file the biweekly payroll reports for the period ending April 4, 2026 paid April 10, 2026.*

### **4. Letter of Support for Bigfoot Trail National Recreation Trail Designation**

- *Recommendation: Approve a letter to Bigfoot Trail Alliance from the City Council endorsing the designation of the Bigfoot Trail as a National Recreation Trail*

### **5. Letter Requesting State to Fund Victim Services**

- *Recommendation: Approve and authorize the Mayor to sign a letter requesting that the State fund victim services in the amount of \$100 million the next fiscal year*

### **6. Abandoned Vehicle Abatement Program Extension**

- *Recommendation: Approve and adopt Resolution No. 2026-29, A RESOLUTION OF THE CITY COUNCIL OF THE CITY OF CRESCENT CITY AUTHORIZING THE EXTENSION OF THE ABANDONED VEHICLE ABATEMENT PROGRAM UNTIL MAY 1, 2037*

### **7. Increase to Maintenance Budget for the WWTP for Repairs Performed by Jacobs**

- *Recommendation: Approve and adopt Resolution No. 2026-30, A RESOLUTION OF THE CITY COUNCIL OF THE CITY OF CRESCENT CITY AMENDING THE FISCAL YEAR 2025-26 BUDGET OF THE CITY OF CRESCENT CITY*

## **PUBLIC HEARING - None**

## **CONTINUING BUSINESS - None**

## **NEW BUSINESS**

### **8. Downtown Farmers Market Location**

- *Recommendation: Hear staff report*
- *Technical questions from the Council*
- *Receive public comment*
- *Further Council discussion*
- *Approve and authorize the City Manager to sign the Agreement with the Del Norte and Tirbal Lands Community Food Council for a Downtown Farmers’ Market Location*

### **9. Letter of Support for Citizens' Dock Pier 2 Construction Project**

- *Recommendation: Hear staff report*
- *Technical questions from the Council*
- *Receive public comment*
- *Further Council discussion*
- *Approve a letter to U.S. Department of Transportation Maritime Administration in support of the Citizens' Dock Pier 2 Construction Project*

### **10. Lighthouse Cove Apartment Remodel Budget Adjustment**

- *Recommendation: Hear staff report*
- *Technical questions from the Council*
- *Receive public comment*
- *Further Council discussion*
- *Approve and adopt Resolution No. 2026-31, A RESOLUTION OF THE CITY COUNCIL OF THE CITY OF CRESCENT CITY AMENDING THE FISCAL YEAR 2025-26 BUDGET OF THE CITY OF CRESCENT CITY*
- *Approve the Plans and Specifications for the Lighthouse Cove RV Park Apartment Project*
- *Direct staff to publish a notice inviting bids for this project*

### **11. Letter of Support for SB 1216 (Cabaldon): Planning and Zoning Law, Housing Leadership Designation**

- *Recommendation: Hear staff report*
- *Technical questions from the Council*
- *Receive public comment*
- *Further Council discussion*
- *Approve and authorize the Mayor to sign a letter of support for SB 1216 (Cabaldon): Planning and Zoning Law, Housing Leadership Designation*

### **12. OPC Grant Award Acceptance for Coastal Resiliency Plan**

- *Recommendation: Hear staff report*
- *Technical questions from the Council*
- *Receive public comment*
- *Further Council discussion*
- *Approve and adopt Resolution No. 2026-32, A RESOLUTION OF THE CITY OF CRESCENT CITY ACCEPTING THE GRANT AWARD FROM OCEAN PROTECTION COUNCIL FOR DEVELOPMENT OF SEA LEVEL RISE ADAPTATION PLANS IN COMPLIANCE WITH SB 272RE OPC GRANT APPLICATION – CRESCENT CITY COASTAL RESILIENCY STRATEGY*

### **13. Military Equipment Use Policy**

- *Recommendation: Hear staff report*
- *Technical questions from the Council*
- *Receive public comment*
- *Further Council discussion*
- *Receive the Military Equipment Use 2025 Annual Report*
- *Waive full reading, read by title only and introduce Ordinance No. 864, AN ORDINANCE OF THE CITY COUNCIL OF THE CITY OF CRESCENT CITY CONFIRMING APPROVAL OF THE CCPD MILITARY EQUIPMENT USE POLICY*

## **CITY COUNCIL ITEMS**

- **Reports, Concerns, Referrals, Council travel and training reports** – In accordance with Gov't Code § 54954.2(a), City Council Members may make brief announcements or brief reports on their own activities. They may ask questions for clarification, make a referral to staff or take action to have staff place a matter of business on a future agenda.
- **Legislative Matters** – Consider miscellaneous legislative matters pertinent to the City of Crescent City. Authorize the Mayor to sign the appropriate letters and/or positions with respect to such matters.
- **City Manager Report and City Council Directives** – Pursuant to Crescent City Municipal Code § 2.08.200, the City Council may instruct the city manager on matters of importance to the administrative services of the City and provide direction with respect to subordinates of the City Manager. (Directives from individual Council Members that are not objected to by any member present shall be considered an order of the City Council.)

## **ADJOURNMENT**

Adjourn to the regular meeting of the City Council of the City of Crescent City on Monday, May 4, 2026 at 6:00 p.m. at the Flynn Center Board Chambers, 981 H Street, Crescent City, CA 95531.

### **POSTED:**

April 16, 2026

/s/ Robin Altman, City Clerk/Administrative Analyst

#### ***Vision:***

The City of Crescent City will continue to stand the test of time and promote quality of life and community pride for our residents, businesses and visitors through leadership, diversity, and teamwork.

#### ***Mission:***

The purpose of our city is to promote a high quality of life, leadership and services to the residents, businesses, and visitors we serve. The City is dedicated to providing the most efficient, innovative and economically sound municipal services building on our diverse history, culture and unique natural resources.

#### ***Values:***

Accountability - Honesty & Integrity - Excellent Customer Service - Effective & Active Communication -Teamwork –  
Fiscally Responsible

# Accounts Payable

## Checks by Date - Summary by Check Number

User: kbates@crescentcity.org  
 Printed: 4/7/2026 1:51 PM

REVIEWED  
 kkozak , 4/7/2026, 3:54:03 PM



Check No	Vendor No	Vendor Name	Check Date	Void Checks	Check Amount
ACH	EDDTAX	State of California EDD TAX Auto Pay	03/30/2026	0.00	7,109.41
ACH	FITTAX	FIT Payroll Taxes Auto Pay	03/30/2026	0.00	27,435.64
ACH	PERS2	Public Emp Retirement Sys	03/30/2026	0.00	40,689.79
ACH	EDDTAX	State of California EDD TAX Auto Pay	03/25/2026	0.00	961.34
ACH	FITTAX	FIT Payroll Taxes Auto Pay	03/25/2026	0.00	2,804.68
450698	ATTClets	A T & T Corp	03/23/2026	0.00	106.84
450699	AMAZON	Amazon Capital Services, Inc	03/23/2026	0.00	3,461.88
450700	BERTSC	Bertsch-Oceanview Csd	03/23/2026	0.00	7,568.29
450701	BLUEST	Blue Star Gas Associates	03/23/2026	0.00	16.14
450702	CURRYE	Brad Coleman Inc	03/23/2026	0.00	685.31
450703	BURTONS	Burton's Fire Inc	03/23/2026	0.00	1,694.40
450704	CRENNE	C Renner Petroleum Inc	03/23/2026	0.00	14,224.41
450705	CAMPTO	Campton Electric Inc	03/23/2026	0.00	26.39
450706	CANON	Canon Solutions America Inc	03/23/2026	0.00	311.09
450707	CHARTEC	Charter Communications	03/23/2026	0.00	3,161.41
450708	CHURCH	Churchtree Csd	03/23/2026	0.00	521.98
450709	CIVICA	Civica Law Group APC	03/23/2026	0.00	10,054.10
450710	CPI	CPI-International Inc	03/23/2026	0.00	2,846.16
450711	CYRUS	Christina Cyrus	03/23/2026	0.00	90.00
450712	DNCOFL	D N Co Flood Control Dist	03/23/2026	0.00	602.51
450713	DNCO	Del Norte County	03/23/2026	0.00	3,707.17
450714	DELCUR	Del-Cur Supply Co-Op	03/23/2026	0.00	314.75
450715	DISTOP	Distributor Operations, Inc.	03/23/2026	0.00	530.32
450716	EFFDEL	Efficiency Delivery LLC	03/23/2026	0.00	30.00
450717	ENGLUN	Englund Marine Supply Co.	03/23/2026	0.00	89.43
450718	EUREKAH	Eureka Humboldt Fire Extinguisher Co Inc	03/23/2026	0.00	3,201.63
450719	FASHIO	Fashion Blacksmith	03/23/2026	0.00	1,999.60
450720	FRESWATE	Freshwater Environmental Services Inc	03/23/2026	0.00	8,175.00
450721	VERIZO2	Frontier California Inc	03/23/2026	0.00	2,839.67
450722	GRAING	Grainger	03/23/2026	0.00	262.57
450723	HDFOWLER	H. D. Fowler Company, Inc	03/23/2026	0.00	2,268.81
450724	HAMWSG	Hambro WSG Inc	03/23/2026	0.00	4,195.03
450725	HEMMIN	Hemmingsen Contracting Co Inc	03/23/2026	0.00	1,066.26
450726	INDUSTST	Industrial Steel & Supply Co, Inc	03/23/2026	0.00	88.07
450727	INFOSEND	Infosend Inc.	03/23/2026	0.00	2,320.47
450728	LESSCH	Les Schwab Tire Centers of California	03/23/2026	0.00	231.94
450729	THRIFT	Malcolm Kelly Inc.	03/23/2026	0.00	186.89
450730	Mayes	Wade Mayes	03/23/2026	0.00	69.00
450731	MISSIO	Mission Linen Supply	03/23/2026	0.00	356.16
450732	MITCHELL	Mitchell Repair Information Company, LLC	03/23/2026	0.00	3,060.00
450733	NYKENEW	Nyke Newton	03/23/2026	0.00	100.00
450734	OREILLY	O'Reilly Auto Enterprises LLC	03/23/2026	0.00	1,593.31
450735	PACESUPP	Pace Supply Corp	03/23/2026	0.00	235.43
450736	MENDES	Pacific Packaging & Supply Co Inc	03/23/2026	0.00	342.83
450737	PACPOW	PacifiCorp	03/23/2026	0.00	49,113.45
450738	PHELAN	Justin Phelan	03/23/2026	0.00	200.00
450739	HITECHSE	Pinger Industries, Inc.	03/23/2026	0.00	824.76

Check No	Vendor No	Vendor Name	Check Date	Void Checks	Check Amount
450740	QUEENJ	James Queen	03/23/2026	0.00	200.00
450741	DRIPDROP	Taylor Queen	03/23/2026	0.00	925.00
450742	RINALDI	David Rinaldi	03/23/2026	0.00	40.00
450743	SPRING	SBRK Finance Holdings, Inc	03/23/2026	0.00	2,776.80
450744	SIMMS	Beth Simms	03/23/2026	0.00	55.00
450745	SMITHMJ	Kimberly D Smith	03/23/2026	0.00	2,469.50
450746	DNOFFI	Debra Stover	03/23/2026	0.00	1,083.24
450747	STOVER	Ward Stover	03/23/2026	0.00	4,174.25
450748	TBPENICK	T.B. Penick & Sons, Inc.	03/23/2026	0.00	11,270.00
450749	RAYMOR	UBEO West, LLC	03/23/2026	0.00	63.85
450750	UNITEDRO	United Rotary Brush Corporation	03/23/2026	0.00	869.18
450751	CALCARDS	US Bank Corporate Pmt Systems	03/23/2026	0.00	2,264.23
450752	WAKECODY	Cody Wakefield	03/23/2026	0.00	98.21
450753	D&SPOWDF	Steven Winkelmann	03/23/2026	0.00	450.00
450754	YEAGERD	David Yeager	03/23/2026	0.00	156.08
450755	CASTATE	CA State Disbursement Unit	03/30/2026	0.00	88.84
450756	WAMUTU	Crescent City Employees Association	03/30/2026	0.00	85.00
450757	CCPOLI	Crescent City Police Officer's Assoc	03/30/2026	0.00	600.00
450758	ICMARE	Mission Square	03/30/2026	0.00	4,291.11
450759	PORACRMT	PORAC RMT	03/30/2026	0.00	600.00
450760	ADAMSASF	Adams Ashby Group	03/30/2026	0.00	3,000.00
450761	AMAZON	Amazon Capital Services, Inc	03/30/2026	0.00	1,175.66
450762	BLUEST	Blue Star Gas Associates	03/30/2026	0.00	312.29
450763	BURTONS	Burton's Fire Inc	03/30/2026	0.00	223.20
450764	ZCAFIREF	California State Firefighter's Assoc	03/30/2026	0.00	340.00
450765	CAMPTO	Campton Electric Inc	03/30/2026	0.00	97.31
450766	DNSOLI	County of Del Norte	03/30/2026	0.00	482.55
450767	DISTOP	Distributor Operations, Inc.	03/30/2026	0.00	143.38
450768	ENGLUN	Englund Marine Supply Co.	03/30/2026	0.00	80.53
450769	EUREKAH	Eureka Humboldt Fire Extinguisher Co Inc	03/30/2026	0.00	532.31
450770	FASTENAL	Fastenal Company	03/30/2026	0.00	997.18
450771	NAPA	GDMI ENT INC	03/30/2026	0.00	1,617.10
450772	UB*06290	DOMINGO GEMIGNIANI	03/30/2026	0.00	304.66
450773	GEORGE	George Petty Inc	03/30/2026	0.00	410.69
450774	GIESKING	Ruth Giesking	03/30/2026	0.00	40.00
450775	GRAING	Grainger	03/30/2026	0.00	1,247.52
450776	HAMWSG	Hambro WSG Inc	03/30/2026	0.00	2,295.02
450777	HEMERIK	Bianca Hemerik	03/30/2026	0.00	13,182.38
450778	INDUSTST	Industrial Steel & Supply Co, Inc	03/30/2026	0.00	116.01
450779	FIREAPP	Kalmikov Enterprises, Inc	03/30/2026	0.00	2,851.31
450780	BICOASTA	KPOD, LLC.	03/30/2026	0.00	450.00
450781	LNCURT	L.N. Curtis & Sons	03/30/2026	0.00	4,645.50
450782	LESSCH	Les Schwab Tire Centers of California	03/30/2026	0.00	38.97
450783	NCLAB	Microbac Laboratories, Inc.	03/30/2026	0.00	1,401.50
450784	MISSIO	Mission Linen Supply	03/30/2026	0.00	269.98
450785	INFINITY	Joseph Nixt	03/30/2026	0.00	9,900.00
450786	OREILLY	O'Reilly Auto Enterprises LLC	03/30/2026	0.00	218.14
450787	PACESUPP	Pace Supply Corp	03/30/2026	0.00	2,153.87
450788	MENDES	Pacific Packaging & Supply Co Inc	03/30/2026	0.00	157.83
450789	PAPEMAT	Pape Group Inc, The	03/30/2026	0.00	1,126.91
450790	HITECHSE	Pinger Industries, Inc.	03/30/2026	0.00	143.97
450791	REDSKY	Red Sky Inc.	03/30/2026	0.00	950.00
450792	SHASTACO	Shasta-Tehama-Trinity Joint Comm College	03/30/2026	0.00	2,492.00
450793	SMITHMJ	Kimberly D Smith	03/30/2026	0.00	406.00
450794	TALLANST	Tristan Smith	03/30/2026	0.00	960.00
450795	CALCARDS	US Bank Corporate Pmt Systems	03/30/2026	0.00	2,520.90
450796	VERIZO3	Verizon Wireless Services LLC	03/30/2026	0.00	2,396.36

Check No	Vendor No	Vendor Name	Check Date	Void Checks	Check Amount
450797	CACEHA	Wieckecke and Associates	03/30/2026	0.00	4,405.77
450798	WOODT	Tara Wood	03/30/2026	0.00	245.10
Report Total (106 checks):				0.00	308,666.51

AP  
03-21-26 to 04-03-26 Council

User: kbates@crestedcity.org  
Printed: 4/7/2026 1:50:21 PM

REVIEWED  
kkozak , 4/7/2026, 3:54:10 PM



Check Numbe	Check Date	Acct 1	Description	Amount	Selected For Void
0	3/25/2026	610-000-2185-00000	PR Batch 02222.03.2026 State Income Tax	880.55	False
0	3/25/2026	610-000-2185-00000	PR Batch 00222.03.2026 State Income Tax	80.79	False
0	3/25/2026	610-000-2189-00000	PR Batch 00222.03.2026 Federal Income Tax	215.43	False
0	3/25/2026	610-000-2188-00000	PR Batch 00222.03.2026 Medicare Employer Portion	34.00	False
0	3/25/2026	610-000-2188-00000	PR Batch 00222.03.2026 Medicare Employee Portion	34.00	False
0	3/25/2026	610-000-2188-00000	PR Batch 02222.03.2026 Medicare Employee Portion	146.69	False
0	3/25/2026	610-000-2188-00000	PR Batch 02222.03.2026 Medicare Employer Portion	146.69	False
0	3/25/2026	610-000-2189-00000	PR Batch 02222.03.2026 Federal Income Tax	2,227.87	False
0	3/30/2026	610-000-2185-00000	PR Batch 00002.03.2026 State Income Tax	4,151.13	False
0	3/30/2026	610-000-2185-00000	PR Batch 00022.03.2026 State Income Tax	2,958.28	False
0	3/30/2026	610-000-2188-00000	PR Batch 00002.03.2026 Medicare Employee Portion	2,005.83	False
0	3/30/2026	610-000-2188-00000	PR Batch 00022.03.2026 Medicare Employer Portion	1,309.86	False
0	3/30/2026	610-000-2188-00000	PR Batch 22222.03.2026 Medicare Employee Portion	2.97	False
0	3/30/2026	610-000-2189-00000	PR Batch 00022.03.2026 Federal Income Tax	7,888.33	False
0	3/30/2026	610-000-2188-00000	PR Batch 00022.03.2026 Medicare Employee Portion	1,309.86	False
0	3/30/2026	610-000-2188-00000	PR Batch 00002.03.2026 Medicare Employer Portion	2,005.83	False
0	3/30/2026	610-000-2189-00000	PR Batch 00002.03.2026 Federal Income Tax	12,909.99	False
0	3/30/2026	610-000-2188-00000	PR Batch 22222.03.2026 Medicare Employer Portion	2.97	False
0	3/30/2026	610-000-2187-00000	PR Batch 00002.03.2026 EE PERS Contribution	9,722.61	False
0	3/30/2026	610-000-2187-00000	PR Batch 00022.03.2026 Survivor Benefit	20.94	False
0	3/30/2026	610-000-2187-00000	PR Batch 00002.03.2026 ER PERS Contribution	12,807.56	False
0	3/30/2026	610-000-2187-00000	PR Batch 00002.03.2026 MO EE PERS Contribution	190.84	False
0	3/30/2026	610-000-2187-00000	PR Batch 00222.03.2026 ER PERS Contribution	186.58	False
0	3/30/2026	610-000-2187-00000	PR Batch 00022.03.2026 ER PERS Contribution	9,289.88	False
0	3/30/2026	610-000-2187-00000	PR Batch 00022.03.2026 EE PERS 4850 Contribution	369.85	False
0	3/30/2026	610-000-2187-00000	PR Batch 00222.03.2026 Survivor Benefit	0.93	False
0	3/30/2026	610-000-2187-00000	PR Batch 00002.03.2026 Survivor Benefit	39.06	False
0	3/30/2026	610-000-2187-00000	PR Batch 00002.03.2026 Service Credit Purchase	413.20	False
0	3/30/2026	610-000-2187-00000	PR Batch 00222.03.2026 EE PERS Contribution	181.66	False
0	3/30/2026	610-000-2187-00000	PR Batch 00022.03.2026 EE PERS Contribution	7,466.68	False
450698	3/23/2026	001-240-4230-00000	FY26 DOJ/CLETS Line- 02/01-02/28/26	106.84	False
450699	3/23/2026	412-114-4310-00000	CH -Office Supplies	0.04	False
450699	3/23/2026	001-470-4310-00000	CH -Office Supplies	0.20	False

Check Numbe	Check Date	Acct 1	Description	Amount	Selected For Void
450699	3/23/2026	419-120-4310-00000	CH -Office Supplies	2.95	False
450699	3/23/2026	001-113-4310-00000	Toner	114.45	False
450699	3/23/2026	001-313-4310-00000	Council/ commission name plates.	9.25	False
450699	3/23/2026	420-115-4390-00000	Cultural center A/V equipment.	28.42	False
450699	3/23/2026	419-371-4390-00000	Straps	18.04	False
450699	3/23/2026	001-480-4340-00000	Chemicals for pool.	49.60	False
450699	3/23/2026	412-100-4310-00000	CH -Office Supplies	0.42	False
450699	3/23/2026	413-113-4310-00000	CH -Office Supplies	0.50	False
450699	3/23/2026	413-120-4310-00000	Thermal rolls.	28.34	False
450699	3/23/2026	413-114-4310-00000	CH -Office Supplies	0.20	False
450699	3/23/2026	001-480-4390-00000	Pool brush.	23.79	False
450699	3/23/2026	001-240-4390-AB109	Starlink accessory.	216.49	False
450699	3/23/2026	419-113-4310-00000	Ribbon cutting frame.	2.39	False
450699	3/23/2026	001-364-4310-00000	CH -Office Supplies	0.55	False
450699	3/23/2026	412-113-4310-00000	CH -Office Supplies	0.06	False
450699	3/23/2026	001-240-4390-AB109	Range training equipment.	363.87	False
450699	3/23/2026	001-113-4310-00000	Council/ commission name plates.	5.91	False
450699	3/23/2026	419-120-4310-00000	Water Dept. Toner	54.09	False
450699	3/23/2026	419-113-4310-00000	CH -Office Supplies	0.51	False
450699	3/23/2026	419-113-4310-00000	Toner	114.45	False
450699	3/23/2026	001-114-4310-00000	CH -Office Supplies	1.19	False
450699	3/23/2026	001-470-4390-00000	Gas pump.	145.35	False
450699	3/23/2026	001-113-4310-00000	Ribbon cutting frame.	2.39	False
450699	3/23/2026	001-480-4310-00000	CH -Office Supplies	0.42	False
450699	3/23/2026	001-350-4310-00000	CH -Office Supplies	1.39	False
450699	3/23/2026	413-130-4310-00000	CH -Office Supplies	0.30	False
450699	3/23/2026	413-111-4310-00000	CH -Office Supplies	0.50	False
450699	3/23/2026	413-114-4310-00000	Folders	3.78	False
450699	3/23/2026	413-113-4310-00000	Council/ commission name plates.	5.91	False
450699	3/23/2026	412-113-4310-00000	Ribbon cutting frame.	0.30	False
450699	3/23/2026	419-371-4310-00000	CH -Office Supplies	1.78	False
450699	3/23/2026	001-130-4310-00000	CH -Office Supplies	0.58	False
450699	3/23/2026	001-250-4310-00000	CH -Office Supplies	0.61	False
450699	3/23/2026	412-114-4310-00000	Toner	0.69	False
450699	3/23/2026	001-240-4390-0CARE	Scene lighting.	649.49	False
450699	3/23/2026	001-470-4390-00000	Flag weight.	400.92	False
450699	3/23/2026	508-508-4390-00000	Carburetor	30.08	False
450699	3/23/2026	413-353-4310-00000	CH -Office Supplies	0.55	False
450699	3/23/2026	413-120-4310-00000	CH -Office Supplies	2.97	False
450699	3/23/2026	419-130-4310-00000	CH -Office Supplies	0.29	False
450699	3/23/2026	420-115-4390-00000	Cultural center A/V equipment.	10.78	False
450699	3/23/2026	412-130-4310-00000	CH -Office Supplies	0.08	False
450699	3/23/2026	412-114-4310-00000	Folders	0.88	False

Check Numbe	Check Date	Acct 1	Description	Amount	Selected For Void
450699	3/23/2026	419-111-4310-00000	CH -Office Supplies	0.55	False
450699	3/23/2026	413-120-4310-00000	Water Dept. Toner	54.09	False
450699	3/23/2026	001-112-4310-00000	CH -Office Supplies	1.14	False
450699	3/23/2026	413-113-4310-00000	Toner	114.45	False
450699	3/23/2026	413-357-4310-00000	CH -Office Supplies	0.98	False
450699	3/23/2026	001-114-4310-00000	Toner	19.38	False
450699	3/23/2026	001-111-4310-00000	CH -Office Supplies	0.53	False
450699	3/23/2026	412-120-4310-00000	CH -Office Supplies	0.46	False
450699	3/23/2026	508-508-4390-00000	Mower blade	133.09	False
450699	3/23/2026	413-353-4390-00000	Straps	18.04	False
450699	3/23/2026	001-471-4310-00000	CH -Office Supplies	0.38	False
450699	3/23/2026	412-113-4310-00000	Toner	14.31	False
450699	3/23/2026	001-313-4310-00000	CH -Office Supplies	0.71	False
450699	3/23/2026	413-113-4310-00000	Ribbon cutting frame.	2.39	False
450699	3/23/2026	419-114-4310-00000	Toner	3.28	False
450699	3/23/2026	419-114-4310-00000	Folders	4.17	False
450699	3/23/2026	001-113-4310-00000	CH -Office Supplies	0.51	False
450699	3/23/2026	412-111-4310-00000	CH -Office Supplies	0.09	False
450699	3/23/2026	001-120-4310-00000	CH -Office Supplies	2.76	False
450699	3/23/2026	001-251-4310-00000	CH -Office Supplies	2.70	False
450699	3/23/2026	419-120-4310-00000	Thermal rolls.	28.34	False
450699	3/23/2026	001-240-4310-00000	Desk mats.	189.96	False
450699	3/23/2026	419-114-4310-00000	CH -Office Supplies	0.23	False
450699	3/23/2026	001-120-4310-00000	Thermal rolls.	28.34	False
450699	3/23/2026	412-113-4310-00000	Council/ commission name plates.	0.74	False
450699	3/23/2026	413-352-4310-00000	CH -Office Supplies	0.25	False
450699	3/23/2026	413-114-4310-00000	Toner	2.96	False
450699	3/23/2026	419-113-4310-00000	Council/ commission name plates.	5.91	False
450699	3/23/2026	420-115-4310-00000	CH -Office Supplies	3.34	False
450699	3/23/2026	001-120-4310-00000	Water Dept. Toner	54.08	False
450699	3/23/2026	001-114-4310-00000	Folders	24.75	False
450699	3/23/2026	001-240-4390-AB109	Range training equipment.	205.60	False
450699	3/23/2026	506-506-4390-00000	Straps	18.03	False
450700	3/23/2026	419-372-3821-41028	Monthly Maintenance: Feb 2026	7,568.29	False
450701	3/23/2026	001-240-4220-00000	FY26 Propane (Acct:1038315) 01/15-02/17/26	16.14	False
450702	3/23/2026	001-470-4390-00000	Trimmer	101.19	False
450702	3/23/2026	001-000-2122-00000	Hearing protectors. TAX	-58.08	False
450702	3/23/2026	506-000-2122-00000	Blower part repair. TAX	-3.47	False
450702	3/23/2026	001-470-4390-00000	CREDIT, correction for pmt posted to wrong acct on 12/22	-154.13	False
450702	3/23/2026	001-000-2122-00000	Trimmer TAX	-7.71	False
450702	3/23/2026	001-470-4390-00000	Hearing protectors.	762.04	False
450702	3/23/2026	506-506-4390-00000	Blower part repair.	45.47	False
450703	3/23/2026	508-508-4390-60003	Water manifold asm for pump operations on truck-emergency repair	1,694.40	False

Check Numbe	Check Date	Acct 1	Description	Amount	Selected For Void
450704	3/23/2026	508-508-4330-00000	FY 26 Annual Diesel and Gas for city facilities/corp yard	8,313.69	False
450704	3/23/2026	508-508-4330-00000	FY 26 Annual Diesel and Gas for city facilities/corp yard	2,798.59	False
450704	3/23/2026	001-240-4330-00000	FY26 Fuel for Patrol Cars: Feb	454.47	False
450704	3/23/2026	001-240-4330-00000	FY26 Fuel for Patrol Cars: Feb	2,657.66	False
450705	3/23/2026	419-371-4390-00000	Wire nut.	26.39	False
450706	3/23/2026	506-506-4450-00000	Copier Services FY25/26: 02/25-03/24/26	21.87	False
450706	3/23/2026	506-506-4450-00000	Copier Services FY25/26: 01/25-02/24/26	231.39	False
450707	3/23/2026	001-120-4230-00000	177063601 CH Internet Service- 03/01-03/31/26	18.83	False
450707	3/23/2026	001-470-4230-00000	177063601 CH Internet Service-03/01-03/31/26	1.37	False
450707	3/23/2026	412-130-4230-00000	177063601 CH Internet Service- 03/01-03/31/26	0.56	False
450707	3/23/2026	001-113-4230-00000	177063601 CH Internet Service- 03/01-03/31/26	3.47	False
450707	3/23/2026	412-114-4230-00000	177063601 CH Internet Service- 03/01-03/31/26	0.29	False
450707	3/23/2026	419-113-4230-00000	177063601 CH Internet Service- 03/01-03/31/26	3.46	False
450707	3/23/2026	419-130-4230-00000	177063601 CH Internet Service- 03/01-03/31/26	1.99	False
450707	3/23/2026	413-353-4230-00000	177063601 CH Internet Service- 03/01-03/31/26	3.80	False
450707	3/23/2026	001-111-4230-00000	177063601 CH Internet Service- 03/01-03/31/26	3.65	False
450707	3/23/2026	413-114-4230-00000	177063601 CH Internet Service- 03/01-03/31/26	1.34	False
450707	3/23/2026	001-114-4230-00000	177063601 CH Internet Service- 03/01-03/31/26	8.17	False
450707	3/23/2026	001-130-4230-00000	177063601 CH Internet Service- 03/01-03/31/26	3.99	False
450707	3/23/2026	412-100-4230-00000	Internet Service -03/01-03/31/26	170.00	False
450707	3/23/2026	001-250-4230-00000	177063601 CH Internet Service- 03/01-03/31/26	4.18	False
450707	3/23/2026	413-130-4230-00000	177063601 CH Internet Service- 03/01-03/31/26	2.00	False
450707	3/23/2026	001-480-4230-00000	177063601 CH Internet Service- 03/01-03/31/26	2.86	False
450707	3/23/2026	001-313-4230-00000	177063601 CH Internet Service- 03/01-03/31/26	4.85	False
450707	3/23/2026	419-120-4230-00000	177063601 CH Internet Service- 03/01-03/31/26	20.16	False
450707	3/23/2026	413-352-4230-00000	broadband for security- 03/01-03/31/26	114.99	False
450707	3/23/2026	001-471-4230-00000	177063601 CH Internet Service- 03/01-03/31/26	2.60	False
450707	3/23/2026	419-114-4230-00000	177063601 CH Internet Service- 03/01-03/31/26	1.58	False
450707	3/23/2026	412-113-4230-00000	177063601 CH Internet Service- 03/01-03/31/26	0.44	False
450707	3/23/2026	412-100-4230-00000	177063601 CH Internet Service- 03/01-03/31/26	2.86	False
450707	3/23/2026	412-111-4230-00000	177063601 CH Internet Service- 03/01-03/31/26	0.56	False
450707	3/23/2026	001-364-4230-00000	177063601 CH Internet Service- 03/01-03/31/26	3.80	False
450707	3/23/2026	419-371-4230-00000	Internet Svc (246787001 - Burtshell)- 03/01-03/31/26	109.99	False
450707	3/23/2026	420-115-4230-00000	177063601 CH Internet Service- 03/01-03/31/26	22.83	False
450707	3/23/2026	419-371-4230-00000	177063601 CH Internet Service- 03/01-03/31/26	12.16	False
450707	3/23/2026	413-352-4230-00000	177063601 CH Internet Service- 03/01-03/31/26	1.70	False
450707	3/23/2026	419-111-4230-00000	177063601 CH Internet Service- 03/01-03/31/26	3.76	False
450707	3/23/2026	001-240-4230-00000	Internet Service - 03/01-03/31/26	169.99	False
450707	3/23/2026	413-113-4230-00000	177063601 CH Internet Service- 03/01-03/31/26	3.47	False
450707	3/23/2026	419-371-4230-00000	Internet Svc (246595701 - Amador) -03/01-03/31/26	159.99	False
450707	3/23/2026	419-371-4230-00000	broadband for security- 03/01-03/31/26	100.00	False
450707	3/23/2026	001-350-4230-00000	177063601 CH Internet Service- 03/01-03/31/26	9.51	False
450707	3/23/2026	413-120-4230-00000	177063601 CH Internet Service- 03/01-03/31/26	20.31	False

Check Numbe	Check Date	Acct 1	Description	Amount	Selected For Void
450707	3/23/2026	001-230-4230-00000	Cable & Internet Service-03/01-03/31/26	141.94	False
450707	3/23/2026	001-112-4230-00000	177063601 CH Internet Service- 03/01-03/31/26	7.77	False
450707	3/23/2026	412-100-4230-00000	TV and WiFi Services FY26 03/01-03/31/26	1,884.52	False
450707	3/23/2026	413-111-4230-00000	177063601 CH Internet Service- 03/01-03/31/26	3.42	False
450707	3/23/2026	412-120-4230-00000	177063601 CH Internet Service- 03/01-03/31/26	3.15	False
450707	3/23/2026	413-357-4230-00000	177063601 CH Internet Service- 03/01-03/31/26	6.66	False
450707	3/23/2026	001-251-4230-00000	177063601 CH Internet Service- 03/01-03/31/26	18.44	False
450707	3/23/2026	419-371-4230-00000	broadband for security- 03/01-03/31/26	100.00	False
450708	3/23/2026	419-372-3822-41029	Monthly Maintenance: Feb 2026	521.98	False
450709	3/23/2026	001-250-4410-01405	Legal Services- Feb '26	8,113.70	False
450709	3/23/2026	001-250-4410-120WC	Legal Services- Feb '26	31.10	False
450709	3/23/2026	001-250-4410-00200	Legal Services- Feb '26	155.50	False
450709	3/23/2026	001-250-4410-01430	Legal Services- Feb '26	1,753.80	False
450710	3/23/2026	413-351-4390-00000	FY26 Microbiology bottles and media	907.37	False
450710	3/23/2026	413-351-4390-00000	FY26 Microbiology bottles and media	1,938.79	False
450711	3/23/2026	001-000-3221-00000	REFUND for stay on 06/21-06/25/26 Con # 13580	4.09	False
450711	3/23/2026	412-000-3570-00000	REFUND for stay on 06/21-06/25/26 Con # 13581	40.91	False
450711	3/23/2026	412-000-3570-00000	REFUND for stay on 06/21-06/25/26 Con # 13580	40.91	False
450711	3/23/2026	001-000-3221-00000	REFUND for stay on 06/21-06/25/26 Con # 13581	4.09	False
450712	3/23/2026	419-372-3823-41030	Monthly Maintenance: Feb 2026	602.51	False
450713	3/23/2026	117-364-4789-00000	RMRA pass-through per annex agreement FY26 Dec Rev	2,603.79	False
450713	3/23/2026	115-364-4787-00000	Gas Tax Sec 2107 pass-through per annex agreement FY26 Jan Rev	634.80	False
450713	3/23/2026	115-364-4785-00000	Gas Tax Sec 2105 pass-through per annex agreement FY26 Jan Rev	468.58	False
450714	3/23/2026	001-000-2122-00000	Potassium nitrate. TAX	-25.97	False
450714	3/23/2026	001-470-4390-00000	Potassium nitrate.	340.72	False
450715	3/23/2026	419-371-4390-00000	Oil	530.32	False
450716	3/23/2026	413-352-4470-00000	FY26 Sample Delivery to NCL for WW and DW	30.00	False
450717	3/23/2026	508-508-4390-00000	Separators kit.	42.99	False
450717	3/23/2026	412-100-4799-COAST	Rags	16.87	False
450717	3/23/2026	001-470-4390-00000	Utility brush.	33.33	False
450717	3/23/2026	419-371-4390-00000	Rags	18.42	False
450717	3/23/2026	001-470-4390-00000	Screws and washers.	8.66	False
450717	3/23/2026	001-470-4390-00000	Drill bit	2.74	False
450717	3/23/2026	413-353-4390-00000	Rags	18.43	False
450717	3/23/2026	506-506-4390-00000	Turnbuckle.	5.85	False
450717	3/23/2026	419-371-4390-00000	Part	20.94	False
450717	3/23/2026	001-251-4390-00000	CREDIT from invoice #135226/5	-78.80	False
450718	3/23/2026	506-506-4450-00000	Fire extinguisher maintenance	552.92	False
450718	3/23/2026	001-112-4450-00000	Fire extinguisher maintenance	139.50	False
450718	3/23/2026	508-508-4450-00000	Fire extinguisher maintenance	1,108.18	False
450718	3/23/2026	001-471-4450-00000	Fire extinguisher maintenance	176.50	False
450718	3/23/2026	413-352-4450-00000	Fire extinguisher maintenance	927.03	False
450718	3/23/2026	412-100-4450-00000	Fire extinguisher maintenance	121.00	False

Check Numbe	Check Date	Acct 1	Description	Amount	Selected For Void
450718	3/23/2026	506-506-4450-00000	Fire extinguisher maintenance	18.50	False
450718	3/23/2026	001-480-4450-00000	Fire extinguisher maintenance	102.50	False
450718	3/23/2026	413-351-4450-00000	Fire extinguisher maintenance	55.50	False
450719	3/23/2026	419-371-4390-00000	Air Vac weather caps. Order 1	999.80	False
450719	3/23/2026	419-371-4390-00000	Air Vac weather caps. Order 2	999.80	False
450720	3/23/2026	419-371-4409-00000	FY26 Cross Connection Services - Task Order 15	1,635.00	False
450720	3/23/2026	413-352-4409-00000	FY26 Sewer Regulatory Services - Task Order 13	872.00	False
450720	3/23/2026	419-371-4409-00000	FY26 Water Regulatory Services - Task Order 12	5,668.00	False
450721	3/23/2026	413-351-4230-00000	707 465-5275 Lab Phone Line -03/01-03/29/26	224.34	False
450721	3/23/2026	001-251-4230-00000	707 465-4405 downstairs fax -03/01-03/29/26	9.25	False
450721	3/23/2026	419-130-4230-00000	707 465-4405 downstairs fax -03/01-03/29/26	1.00	False
450721	3/23/2026	412-113-4230-00000	707 465-4405 downstairs fax -03/01-03/29/26	0.22	False
450721	3/23/2026	413-120-4230-00000	707 465-4405 downstairs fax -03/01-03/29/26	10.18	False
450721	3/23/2026	413-352-4230-00000	707 465-4405 downstairs fax -03/01-03/29/26	0.85	False
450721	3/23/2026	412-120-4230-00000	707 465-4405 downstairs fax -03/01-03/29/26	1.58	False
450721	3/23/2026	001-350-4230-00000	707 465-4405 downstairs fax -03/01-03/29/26	4.77	False
450721	3/23/2026	419-113-4230-00000	707 465-4405 downstairs fax -03/01-03/29/26	1.74	False
450721	3/23/2026	001-364-4230-00000	707 465-4405 downstairs fax -03/01-03/29/26	1.91	False
450721	3/23/2026	001-120-4230-00000	707 465-4405 downstairs fax -03/01-03/29/26	9.44	False
450721	3/23/2026	508-508-4230-00000	707-464-6628 Corp Yard Fax -03/01-03/29/26	186.86	False
450721	3/23/2026	001-480-4230-00000	707-464-1372 monthly phone -03/01-03/29/26	127.49	False
450721	3/23/2026	001-470-4230-00000	707 465-4405 downstairs fax -03/01-03/29/26	0.69	False
450721	3/23/2026	413-130-4230-00000	707 465-4405 downstairs fax -03/01-03/29/26	1.00	False
450721	3/23/2026	413-111-4230-00000	707 465-4405 downstairs fax -03/01-03/29/26	1.71	False
450721	3/23/2026	412-100-4230-00000	707 465-4405 downstairs fax -03/01-03/29/26	1.44	False
450721	3/23/2026	419-371-4230-00000	707 465-4405 downstairs fax -03/01-03/29/26	6.10	False
450721	3/23/2026	412-114-4230-00000	707 465-4405 downstairs fax -03/01-03/29/26	0.15	False
450721	3/23/2026	419-120-4230-00000	707 465-4405 downstairs fax -03/01-03/29/26	10.12	False
450721	3/23/2026	001-471-4230-00000	707 465-4405 downstairs fax -03/01-03/29/26	1.30	False
450721	3/23/2026	001-250-4230-00000	707 465-4405 downstairs fax -03/01-03/29/26	2.09	False
450721	3/23/2026	413-357-4230-00000	707 465-4405 downstairs fax -03/01-03/29/26	3.34	False
450721	3/23/2026	419-114-4230-00000	707 465-4405 downstairs fax -03/01-03/29/26	0.79	False
450721	3/23/2026	413-113-4230-00000	707 465-4405 downstairs fax -03/01-03/29/26	1.74	False
450721	3/23/2026	001-471-4230-00000	Cult Cntr Elev Alrm 707-464-4582 -03/01-03/29/26	116.25	False
450721	3/23/2026	412-130-4230-00000	707 465-4405 downstairs fax -03/01-03/29/26	0.28	False
450721	3/23/2026	420-115-4230-00000	707 465-4405 downstairs fax -03/01-03/29/26	11.45	False
450721	3/23/2026	001-111-4230-00000	707 465-4405 downstairs fax -03/01-03/29/26	1.83	False
450721	3/23/2026	001-114-4230-00000	707 465-4405 downstairs fax -03/01-03/29/26	4.10	False
450721	3/23/2026	001-130-4230-00000	707 465-4405 downstairs fax -03/01-03/29/26	2.00	False
450721	3/23/2026	001-471-4230-00000	707-465-3914 monthly phone -03/01-03/29/26	118.11	False
450721	3/23/2026	001-480-4230-00000	707 465-4405 downstairs fax -03/01-03/29/26	1.43	False
450721	3/23/2026	001-313-4230-00000	707 465-4405 downstairs fax -03/01-03/29/26	2.44	False
450721	3/23/2026	413-352-4230-00000	Treatment Plant Phone: 465-3054 -03/01-03/29/26	308.58	False

Check Numbe	Check Date	Acct 1	Description	Amount	Selected For Void
450721	3/23/2026	413-352-4230-00000	WWTP phone -03/01-03/29/26	340.42	False
450721	3/23/2026	001-113-4230-00000	707 465-4405 downstairs fax -03/01-03/29/26	1.74	False
450721	3/23/2026	001-112-4230-00000	707 465-4405 downstairs fax -03/01-03/29/26	3.89	False
450721	3/23/2026	412-111-4230-00000	707 465-4405 downstairs fax -03/01-03/29/26	0.29	False
450721	3/23/2026	001-240-4230-00000	707-465-5129 monthly phone -03/01-03/29/26	186.86	False
450721	3/23/2026	419-371-4230-00000	707-001-0001 SCADA telemetry link -03/01-03/29/26	56.97	False
450721	3/23/2026	420-115-4230-00000	707-197-0009 monthly phone- 03/02-04/01/26	790.00	False
450721	3/23/2026	413-114-4230-00000	707 465-4405 downstairs fax -03/01-03/29/26	0.67	False
450721	3/23/2026	413-353-4230-00000	707 465-4405 downstairs fax -03/01-03/29/26	1.91	False
450721	3/23/2026	001-480-4230-00000	707-464-6940 monthly phone -03/01-03/29/26	104.47	False
450721	3/23/2026	419-111-4230-00000	707 465-4405 downstairs fax -03/01-03/29/26	1.89	False
450722	3/23/2026	413-353-4390-00000	Mobile scanner.	77.15	False
450722	3/23/2026	508-508-4390-00000	Makita Switch	31.13	False
450722	3/23/2026	001-364-4390-10025	Mobile scanner.	77.14	False
450722	3/23/2026	419-371-4390-00000	Mobile scanner.	77.15	False
450723	3/23/2026	419-000-2122-00000	Parts. TAX	-69.79	False
450723	3/23/2026	419-000-2122-00000	Saddle TAX	-7.30	False
450723	3/23/2026	419-371-4390-00000	Parts.	915.69	False
450723	3/23/2026	001-470-4390-00000	CREDIT from invoice # I7086202	-392.00	False
450723	3/23/2026	419-371-4390-00000	Parts.	1,064.42	False
450723	3/23/2026	001-470-4390-00000	Powder coat enclosure.	662.01	False
450723	3/23/2026	419-371-4390-00000	Saddle	95.78	False
450724	3/23/2026	413-000-1202-00000	Sludge processing.	2,278.94	False
450724	3/23/2026	413-000-1202-00000	Sludge processing.	1,916.09	False
450725	3/23/2026	412-100-4390-00000	Base rock.	822.70	False
450725	3/23/2026	001-470-4390-00000	Dirt	243.56	False
450726	3/23/2026	508-508-4390-00000	Bandsaw blades.	88.07	False
450727	3/23/2026	413-120-4240-00000	Print and Mail Utility Bills Feb '26	1,160.23	False
450727	3/23/2026	419-120-4240-00000	Print and Mail Utility Bills Feb '26	1,160.24	False
450728	3/23/2026	001-240-4391-00000	Flat tire repair.	231.94	False
450729	3/23/2026	508-508-4390-00000	Wheel.	23.62	False
450729	3/23/2026	419-371-4390-00000	Parts	98.93	False
450729	3/23/2026	001-470-4390-00000	Parts	37.94	False
450729	3/23/2026	419-371-4390-00000	Coupling.	26.40	False
450730	3/23/2026	419-371-4530-00000	REISSUANCE ck 449153-7/29-7/31/25: Salinas,CA (Water Op Classes)	69.00	False
450731	3/23/2026	001-120-4370-00000	City Hall Mats	2.30	False
450731	3/23/2026	001-130-4370-00000	City Hall Mats	0.48	False
450731	3/23/2026	001-111-4370-00000	City Hall Mats	0.45	False
450731	3/23/2026	001-113-4370-00000	City Hall Mats	0.42	False
450731	3/23/2026	412-100-4370-00000	City Hall Mats	0.35	False
450731	3/23/2026	001-251-4370-00000	City Hall Mats	2.25	False
450731	3/23/2026	419-371-4370-00000	City Hall Mats	1.49	False
450731	3/23/2026	412-130-4370-00000	City Hall Mats	0.07	False

Check Numbe	Check Date	Acct 1	Description	Amount	Selected For Void
450731	3/23/2026	001-471-4370-00000	City Hall Mats	0.31	False
450731	3/23/2026	001-313-4370-00000	City Hall Mats	0.59	False
450731	3/23/2026	419-130-4370-00000	City Hall Mats	0.25	False
450731	3/23/2026	412-120-4370-00000	City Hall Mats	0.39	False
450731	3/23/2026	419-114-4370-00000	City Hall Mats	0.19	False
450731	3/23/2026	001-112-4370-00000	City Hall Mats	0.95	False
450731	3/23/2026	413-351-4320-00000	FY 26 Laundry services. Pool	72.48	False
450731	3/23/2026	413-357-4370-00000	City Hall Mats	0.82	False
450731	3/23/2026	419-371-4370-00000	City Hall Mats	1.49	False
450731	3/23/2026	413-130-4370-00000	City Hall Mats	0.24	False
450731	3/23/2026	001-250-4370-00000	City Hall Mats	0.51	False
450731	3/23/2026	413-120-4370-00000	City Hall Mats	2.48	False
450731	3/23/2026	412-120-4370-00000	City Hall Mats	0.39	False
450731	3/23/2026	001-113-4370-00000	City Hall Mats	0.42	False
450731	3/23/2026	001-364-4370-00000	City Hall Mats	0.47	False
450731	3/23/2026	412-113-4370-00000	City Hall Mats	0.06	False
450731	3/23/2026	001-120-4370-00000	City Hall Mats	2.30	False
450731	3/23/2026	001-350-4370-00000	City Hall Mats	1.16	False
450731	3/23/2026	413-113-4370-00000	City Hall Mats	0.42	False
450731	3/23/2026	413-352-4370-00000	City Hall Mats	0.20	False
450731	3/23/2026	001-114-4370-00000	City Hall Mats	0.99	False
450731	3/23/2026	001-120-4370-00000	City Hall Mats	2.30	False
450731	3/23/2026	412-114-4370-00000	City Hall Mats	0.03	False
450731	3/23/2026	001-350-4370-00000	City Hall Mats	1.16	False
450731	3/23/2026	413-357-4370-00000	City Hall Mats	0.82	False
450731	3/23/2026	419-111-4370-00000	City Hall Mats	0.46	False
450731	3/23/2026	419-120-4370-00000	City Hall Mats	2.47	False
450731	3/23/2026	412-111-4370-00000	City Hall Mats	0.07	False
450731	3/23/2026	420-115-4370-00000	City Hall Mats	2.79	False
450731	3/23/2026	419-111-4370-00000	City Hall Mats	0.46	False
450731	3/23/2026	413-353-4320-00000	FY 26 Laundry services/uniforms	54.14	False
450731	3/23/2026	413-120-4370-00000	City Hall Mats	2.48	False
450731	3/23/2026	001-364-4370-00000	City Hall Mats	0.47	False
450731	3/23/2026	420-115-4370-00000	City Hall Mats	2.79	False
450731	3/23/2026	001-251-4370-00000	City Hall Mats	2.25	False
450731	3/23/2026	001-114-4370-00000	City Hall Mats	0.99	False
450731	3/23/2026	001-112-4370-00000	City Hall Mats	0.95	False
450731	3/23/2026	413-352-4370-00000	City Hall Mats	0.20	False
450731	3/23/2026	420-115-4370-00000	City Hall Mats	2.79	False
450731	3/23/2026	419-111-4370-00000	City Hall Mats	0.46	False
450731	3/23/2026	412-111-4370-00000	City Hall Mats	0.07	False
450731	3/23/2026	412-130-4370-00000	City Hall Mats	0.07	False
450731	3/23/2026	001-114-4370-00000	City Hall Mats	0.99	False

Check Numbe	Check Date	Acct 1	Description	Amount	Selected For Void
450731	3/23/2026	412-100-4370-00000	City Hall Mats	0.35	False
450731	3/23/2026	413-353-4370-00000	City Hall Mats	0.47	False
450731	3/23/2026	001-130-4370-00000	City Hall Mats	0.48	False
450731	3/23/2026	413-111-4370-00000	City Hall Mats	0.42	False
450731	3/23/2026	001-480-4370-00000	City Hall Mats	0.35	False
450731	3/23/2026	001-112-4370-00000	City Hall Mats	0.95	False
450731	3/23/2026	413-130-4370-00000	City Hall Mats	0.24	False
450731	3/23/2026	412-100-4370-00000	City Hall Mats	0.35	False
450731	3/23/2026	001-480-4370-00000	City Hall Mats	0.35	False
450731	3/23/2026	412-113-4370-00000	City Hall Mats	0.06	False
450731	3/23/2026	419-130-4370-00000	City Hall Mats	0.25	False
450731	3/23/2026	412-111-4370-00000	City Hall Mats	0.07	False
450731	3/23/2026	001-111-4370-00000	City Hall Mats	0.45	False
450731	3/23/2026	413-113-4370-00000	City Hall Mats	0.42	False
450731	3/23/2026	413-114-4370-00000	City Hall Mats	0.17	False
450731	3/23/2026	419-113-4370-00000	City Hall Mats	0.42	False
450731	3/23/2026	419-114-4370-00000	City Hall Mats	0.19	False
450731	3/23/2026	001-250-4370-00000	City Hall Mats	0.51	False
450731	3/23/2026	419-113-4370-00000	City Hall Mats	0.42	False
450731	3/23/2026	001-480-4370-00000	City Hall Mats	0.35	False
450731	3/23/2026	001-113-4370-00000	City Hall Mats	0.42	False
450731	3/23/2026	413-114-4370-00000	City Hall Mats	0.17	False
450731	3/23/2026	001-471-4370-00000	City Hall Mats	0.31	False
450731	3/23/2026	413-351-4320-00000	FY 26 Laundry services/uniforms. WWTP	26.19	False
450731	3/23/2026	419-120-4370-00000	City Hall Mats	2.47	False
450731	3/23/2026	413-114-4370-00000	City Hall Mats	0.17	False
450731	3/23/2026	413-113-4370-00000	City Hall Mats	0.42	False
450731	3/23/2026	412-130-4370-00000	City Hall Mats	0.07	False
450731	3/23/2026	001-350-4370-00000	City Hall Mats	1.16	False
450731	3/23/2026	001-251-4370-00000	City Hall Mats	2.25	False
450731	3/23/2026	412-120-4370-00000	City Hall Mats	0.39	False
450731	3/23/2026	001-250-4370-00000	City Hall Mats	0.51	False
450731	3/23/2026	419-114-4370-00000	City Hall Mats	0.19	False
450731	3/23/2026	413-111-4370-00000	City Hall Mats	0.42	False
450731	3/23/2026	001-471-4370-00000	City Hall Mats	0.31	False
450731	3/23/2026	419-130-4370-00000	City Hall Mats	0.25	False
450731	3/23/2026	001-313-4370-00000	City Hall Mats	0.59	False
450731	3/23/2026	413-353-4370-00000	City Hall Mats	0.47	False
450731	3/23/2026	508-508-4320-00000	FY 26 Laundry services/uniforms	35.33	False
450731	3/23/2026	001-470-4370-00000	City Hall Mats	0.17	False
450731	3/23/2026	001-111-4370-00000	City Hall Mats	0.45	False
450731	3/23/2026	412-114-4370-00000	City Hall Mats	0.03	False
450731	3/23/2026	413-357-4370-00000	City Hall Mats	0.82	False

Check Numbe	Check Date	Acct 1	Description	Amount	Selected For Void
450731	3/23/2026	001-130-4370-00000	City Hall Mats	0.48	False
450731	3/23/2026	413-120-4370-00000	City Hall Mats	2.48	False
450731	3/23/2026	001-470-4370-00000	City Hall Mats	0.17	False
450731	3/23/2026	413-130-4370-00000	City Hall Mats	0.24	False
450731	3/23/2026	412-113-4370-00000	City Hall Mats	0.06	False
450731	3/23/2026	413-351-4320-00000	FY 26 Laundry services/uniforms	18.56	False
450731	3/23/2026	419-371-4370-00000	City Hall Mats	1.49	False
450731	3/23/2026	413-352-4370-00000	City Hall Mats	0.20	False
450731	3/23/2026	413-353-4370-00000	City Hall Mats	0.47	False
450731	3/23/2026	413-111-4370-00000	City Hall Mats	0.42	False
450731	3/23/2026	412-114-4370-00000	City Hall Mats	0.03	False
450731	3/23/2026	001-313-4370-00000	City Hall Mats	0.59	False
450731	3/23/2026	419-120-4370-00000	City Hall Mats	2.47	False
450731	3/23/2026	001-470-4370-00000	City Hall Mats	0.17	False
450731	3/23/2026	419-113-4370-00000	City Hall Mats	0.42	False
450731	3/23/2026	001-364-4370-00000	City Hall Mats	0.47	False
450731	3/23/2026	001-480-4370-00000	FY 26 Laundry services. Pool mats and towels.	72.48	False
450732	3/23/2026	508-508-4450-00000	Mitchell 1 for diag of vehicles	3,060.00	False
450733	3/23/2026	412-100-4390-00000	RV park firewood bundles.	100.00	False
450734	3/23/2026	508-508-4390-00000	Floor mat	35.71	False
450734	3/23/2026	001-230-4390-00000	Lawn mower battery.	62.55	False
450734	3/23/2026	001-230-4390-00000	Fire rig washing supplies.	73.55	False
450734	3/23/2026	508-508-4390-00000	LED parts	135.62	False
450734	3/23/2026	001-240-4391-00000	Switch assembly.	80.04	False
450734	3/23/2026	001-230-4391-00000	DEF for 5111	51.68	False
450734	3/23/2026	508-508-4390-60001	Heater core	87.64	False
450734	3/23/2026	001-240-4391-00000	Breaks	730.97	False
450734	3/23/2026	508-508-4390-60001	Rotor and pad	335.55	False
450735	3/23/2026	419-371-4390-00000	Grease cart.	235.43	False
450736	3/23/2026	001-480-4370-00000	Janitorial.	342.83	False
450737	3/23/2026	001-240-4210-00000	ITEM 14 Service at 686 G St - PD	968.75	False
450737	3/23/2026	419-371-4210-00000	ITEM 100 Service at 4605 Kings Valley Rd - pump	36.76	False
450737	3/23/2026	001-480-4210-2020S	ITEM 25 Service at 1000 Play St - Pool	5,187.18	False
450737	3/23/2026	001-480-4210-00000	ITEM 12 Service at 1001 Front St - Tsunami Siren	0.45	False
450737	3/23/2026	001-471-4210-00000	ITEM 12 Service at 1001 Front St - Tsunami Siren	0.42	False
450737	3/23/2026	001-114-4210-00000	ITEM 91 Service at 377 J St - Svc to Clock	2.52	False
450737	3/23/2026	419-130-4210-00000	ITEM 91 Service at 377 J St - Svc to Clock	0.62	False
450737	3/23/2026	001-364-4210-10023	ITEM 88 Service - Streetlights	496.41	False
450737	3/23/2026	413-113-4210-00000	ITEM 91 Service at 377 J St - Svc to Clock	1.07	False
450737	3/23/2026	001-364-4210-10023	ITEM 116 Service at 391 Front St -Corner Front&D	169.06	False
450737	3/23/2026	413-352-4210-00000	ITEM 12 Service at 1001 Front St - Tsunami Siren	0.27	False
450737	3/23/2026	412-113-4210-00000	ITEM 91 Service at 377 J St - Svc to Clock	0.14	False
450737	3/23/2026	412-100-4210-00000	ITEM 81 Service at 377 J St - City Hall	9.46	False

Check Numbe	Check Date	Acct 1	Description	Amount	Selected For Void
450737	3/23/2026	508-508-4210-00000	ITEM 33 Service at Garage - Shop	1,521.75	False
450737	3/23/2026	419-371-4210-00000	ITEM 91 Service at 377 J St - Svc to Clock	3.75	False
450737	3/23/2026	001-470-4210-00000	ITEM 12 Service at 1001 Front St - Tsunami Siren	0.21	False
450737	3/23/2026	412-114-4210-00000	ITEM 81 Service at 377 J St - City Hall	0.97	False
450737	3/23/2026	001-350-4210-00000	ITEM 12 Service at 1001 Front St - Tsunami Siren	1.51	False
450737	3/23/2026	419-114-4210-00000	ITEM 91 Service at 377 J St - Svc to Clock	0.49	False
450737	3/23/2026	001-364-4210-10023	ITEM 53 Service - Streetlights	2,190.21	False
450737	3/23/2026	001-240-4210-00000	ITEM 99 Service at 686 G St to Shop - PD	22.87	False
450737	3/23/2026	413-113-4210-00000	ITEM 12 Service at 1001 Front St - Tsunami Siren	0.55	False
450737	3/23/2026	001-350-4210-00000	ITEM 81 Service at 377 J St - City Hall	31.52	False
450737	3/23/2026	001-130-4210-00000	ITEM 12 Service at 1001 Front St - Tsunami Siren	0.63	False
450737	3/23/2026	413-353-4210-35019	ITEM 112 Service at Breen Street Pump	69.45	False
450737	3/23/2026	001-470-4210-00000	ITEM 81 Service at 377 J St - City Hall	4.52	False
450737	3/23/2026	001-364-4210-00000	ITEM 91 Service at 377 J St - Svc to Clock	1.18	False
450737	3/23/2026	001-113-4210-00000	ITEM 91 Service at 377 J St - Svc to Clock	1.07	False
450737	3/23/2026	419-120-4210-00000	ITEM 12 Service at 1001 Front St - Tsunami Siren	3.19	False
450737	3/23/2026	419-371-4210-00000	ITEM 119 Service at ABT Lake Earl Dr - Pump	29.68	False
450737	3/23/2026	419-371-4210-00000	ITEM 102 Service of Wonderstump Wtr Twr	119.03	False
450737	3/23/2026	001-250-4210-00000	ITEM 91 Service at 377 J St - Svc to Clock	1.29	False
450737	3/23/2026	419-114-4210-00000	ITEM 12 Service at 1001 Front St - Tsunami Siren	0.25	False
450737	3/23/2026	001-470-4210-00000	ITEM 110 Service at 1397 Front St	21.50	False
450737	3/23/2026	419-371-4210-00000	ITEM 101 Service at 4605 Kings Valley -Pumphouse	26.95	False
450737	3/23/2026	001-350-4210-00000	ITEM 91 Service at 377 J St - Svc to Clock	2.94	False
450737	3/23/2026	001-470-4210-00000	ITEM 29 Service at Mason Mall Lighting - Parks	44.37	False
450737	3/23/2026	412-120-4210-00000	ITEM 91 Service at 377 J St - Svc to Clock	0.97	False
450737	3/23/2026	419-371-4210-00000	ITEM 12 Service at 1001 Front St - Tsunami Siren	1.93	False
450737	3/23/2026	412-111-4210-00000	ITEM 91 Service at 377 J St - Svc to Clock	0.18	False
450737	3/23/2026	412-113-4210-00000	ITEM 12 Service at 1001 Front St - Tsunami Siren	0.07	False
450737	3/23/2026	001-250-4210-00000	ITEM 12 Service at 1001 Front St - Tsunami Siren	0.66	False
450737	3/23/2026	419-371-4210-00000	ITEM 87 Service at 4241 US Hwy 101 N	104.96	False
450737	3/23/2026	001-114-4210-00000	ITEM 81 Service at 377 J St - City Hall	27.07	False
450737	3/23/2026	001-470-4210-00000	ITEM 96 Service at 424 Howe Dr - MarineMml Rstrm	35.38	False
450737	3/23/2026	001-120-4210-00000	ITEM 12 Service at 1001 Front St - Tsunami Siren	2.99	False
450737	3/23/2026	001-120-4210-00000	ITEM 81 Service at 377 J St - City Hall	62.41	False
450737	3/23/2026	001-120-4210-00000	ITEM 91 Service at 377 J St - Svc to Clock	5.81	False
450737	3/23/2026	413-111-4210-00000	ITEM 81 Service at 377 J St - City Hall	11.34	False
450737	3/23/2026	001-470-4210-00000	ITEM 21 Service at Mall Ltg Oasis Trms - Parks	21.50	False
450737	3/23/2026	413-111-4210-00000	ITEM 91 Service at 377 J St - Svc to Clock	1.06	False
450737	3/23/2026	001-111-4210-00000	ITEM 91 Service at 377 J St - Svc to Clock	1.12	False
450737	3/23/2026	419-371-4210-00000	ITEM 105 Service at ABT 500 E Cooper Ave	30.21	False
450737	3/23/2026	001-364-4210-10023	ITEM 52 Service - Streetlights	22.07	False
450737	3/23/2026	001-364-4210-10023	ITEM 121 Service - Streetlights	10.93	False
450737	3/23/2026	001-364-4210-10023	ITEM 120 Service - Streetlights	217.88	False

Check Numbe	Check Date	Acct 1	Description	Amount	Selected For Void
450737	3/23/2026	420-115-4210-00000	ITEM 81 Service at 377 J St - City Hall	75.63	False
450737	3/23/2026	001-130-4210-00000	ITEM 91 Service at 377 J St - Svc to Clock	1.23	False
450737	3/23/2026	413-130-4210-00000	ITEM 12 Service at 1001 Front St - Tsunami Siren	0.31	False
450737	3/23/2026	413-353-4210-00000	ITEM 12 Service at 1001 Front St - Tsunami Siren	0.60	False
450737	3/23/2026	413-113-4210-00000	ITEM 81 Service at 377 J St - City Hall	11.48	False
450737	3/23/2026	413-353-4210-00000	ITEM 91 Service at 377 J St - Svc to Clock	1.17	False
450737	3/23/2026	412-130-4210-00000	ITEM 81 Service at 377 J St - City Hall	1.88	False
450737	3/23/2026	001-470-4210-00000	ITEM 97 Service at B St Pier Lighting - Parks	83.04	False
450737	3/23/2026	419-120-4210-00000	ITEM 81 Service at 377 J St - City Hall	66.79	False
450737	3/23/2026	001-112-4210-00000	ITEM 12 Service at 1001 Front St - Tsunami Siren	1.23	False
450737	3/23/2026	001-313-4210-00000	ITEM 81 Service at 377 J St - City Hall	16.08	False
450737	3/23/2026	419-371-4210-00000	ITEM 56 Service at NE Cor W S Rd & EV X Rd Pump	29.49	False
450737	3/23/2026	001-470-4210-00000	ITEM 98 Service at Front & Play - Kid Town Rstrm	47.09	False
450737	3/23/2026	413-357-4210-00000	ITEM 81 Service at 377 J St - City Hall	22.05	False
450737	3/23/2026	413-120-4210-00000	ITEM 81 Service at 377 J St - City Hall	67.28	False
450737	3/23/2026	419-371-4210-00000	ITEM 49 Service 206 Elk Valley Rd Pump Station	2,280.21	False
450737	3/23/2026	001-114-4210-00000	ITEM 12 Service at 1001 Front St - Tsunami Siren	1.29	False
450737	3/23/2026	412-114-4210-00000	ITEM 91 Service at 377 J St - Svc to Clock	0.09	False
450737	3/23/2026	419-120-4210-00000	ITEM 91 Service at 377 J St - Svc to Clock	6.22	False
450737	3/23/2026	413-120-4210-00000	ITEM 91 Service at 377 J St - Svc to Clock	6.27	False
450737	3/23/2026	001-250-4210-00000	ITEM 81 Service at 377 J St - City Hall	13.84	False
450737	3/23/2026	001-364-4210-00000	ITEM 81 Service at 377 J St - City Hall	12.60	False
450737	3/23/2026	001-470-4210-00000	ITEM 103 Service at Mall for Lighting - Parks	95.01	False
450737	3/23/2026	420-115-4210-00000	ITEM 12 Service at 1001 Front St - Tsunami Siren	3.62	False
450737	3/23/2026	419-371-4210-00000	ITEM 81 Service at 377 J St - City Hall	40.28	False
450737	3/23/2026	001-130-4210-00000	ITEM 81 Service at 377 J St - City Hall	13.22	False
450737	3/23/2026	001-470-4210-00000	ITEM 93 Service at 7th & E St - Parks	73.78	False
450737	3/23/2026	001-112-4210-00000	ITEM 91 Service at 377 J St - Svc to Clock	2.39	False
450737	3/23/2026	413-353-4210-35019	ITEM 2 Service at Pacific & A - Sewer lift	38.43	False
450737	3/23/2026	413-353-4210-35019	ITEM 78 Service at 206 Williams Dr - Lift Statio	108.50	False
450737	3/23/2026	413-353-4210-35019	ITEM 86 Service at Pacific & A - Sewer Lift	67.35	False
450737	3/23/2026	419-130-4210-00000	ITEM 12 Service at 1001 Front St - Tsunami Siren	0.32	False
450737	3/23/2026	001-251-4210-00000	ITEM 81 Service at 377 J St - City Hall	61.09	False
450737	3/23/2026	419-111-4210-00000	ITEM 91 Service at 377 J St - Svc to Clock	1.16	False
450737	3/23/2026	001-313-4210-00000	ITEM 91 Service at 377 J St - Svc to Clock	1.49	False
450737	3/23/2026	001-470-4210-00000	ITEM 95 Service at 184 Battery - Park Restrooms	35.94	False
450737	3/23/2026	412-120-4210-00000	ITEM 12 Service at 1001 Front St - Tsunami Siren	0.50	False
450737	3/23/2026	412-120-4210-00000	ITEM 81 Service at 377 J St - City Hall	10.44	False
450737	3/23/2026	001-470-4210-00000	ITEM 94 Service at 1205 Front St - Park Sprmklrs	21.50	False
450737	3/23/2026	413-357-4210-00000	ITEM 91 Service at 377 J St - Svc to Clock	2.05	False
450737	3/23/2026	001-313-4210-00000	ITEM 12 Service at 1001 Front St - Tsunami Siren	0.77	False
450737	3/23/2026	419-371-4210-00000	ITEM 114 Service at ABT 3160 Parkway Dr	26.68	False
450737	3/23/2026	413-353-4210-35019	ITEM 118 Service at Front & N - Lift Station	148.20	False

Check Numbe	Check Date	Acct 1	Description	Amount	Selected For Void
450737	3/23/2026	413-114-4210-00000	ITEM 91 Service at 377 J St - Svc to Clock	0.41	False
450737	3/23/2026	001-470-4210-00000	ITEM 106 Service at Bro John Park Rstrms	25.31	False
450737	3/23/2026	001-471-4210-00000	ITEM 91 Service at 377 J St - Svc to Clock	0.81	False
450737	3/23/2026	001-364-4210-10023	ITEM 123 Service - Streetlights	29.81	False
450737	3/23/2026	412-130-4210-00000	ITEM 91 Service at 377 J St - Svc to Clock	0.17	False
450737	3/23/2026	001-470-4210-00000	ITEM 91 Service at 377 J St - Svc to Clock	0.42	False
450737	3/23/2026	413-351-4210-00000	ITEM 11 Service at 195 B St - Lab	1,295.20	False
450737	3/23/2026	413-120-4210-00000	ITEM 12 Service at 1001 Front St - Tsunami Siren	3.22	False
450737	3/23/2026	413-352-4210-00000	ITEM 81 Service at 377 J St - City Hall	5.64	False
450737	3/23/2026	001-112-4210-00000	ITEM 85 Service at 240 H St - Art Museum	266.55	False
450737	3/23/2026	419-371-4210-00000	ITEM 42 Service at NE Cor Macken & Amador Pump	1,538.12	False
450737	3/23/2026	001-111-4210-00000	ITEM 81 Service at 377 J St - City Hall	12.11	False
450737	3/23/2026	001-251-4210-00000	ITEM 91 Service at 377 J St - Svc to Clock	5.69	False
450737	3/23/2026	001-480-4210-00000	ITEM 91 Service at 377 J St - Svc to Clock	0.89	False
450737	3/23/2026	413-130-4210-00000	ITEM 81 Service at 377 J St - City Hall	6.61	False
450737	3/23/2026	001-112-4210-00000	ITEM 81 Service at 377 J St - City Hall	25.74	False
450737	3/23/2026	412-113-4210-00000	ITEM 81 Service at 377 J St - City Hall	1.46	False
450737	3/23/2026	508-508-4210-00000	ITEM 107 Service at 10th&I Strg & Lunch Rm -shop	495.85	False
450737	3/23/2026	419-371-4210-00000	ITEM 61 Service at 46900 S Bank Rd - Water	17,677.33	False
450737	3/23/2026	001-364-4210-10023	ITEM 115 Service at 391 Front St - Streetlights	185.93	False
450737	3/23/2026	413-353-4210-00000	ITEM 81 Service at 377 J St - City Hall	12.60	False
450737	3/23/2026	001-113-4210-00000	ITEM 12 Service at 1001 Front St - Tsunami Siren	0.55	False
450737	3/23/2026	001-111-4210-00000	ITEM 12 Service at 1001 Front St - Tsunami Siren	0.58	False
450737	3/23/2026	001-364-4210-10023	ITEM 77 Service - Streetlights	3,467.39	False
450737	3/23/2026	412-111-4210-00000	ITEM 12 Service at 1001 Front St - Tsunami Siren	0.09	False
450737	3/23/2026	412-100-4210-00000	ITEM 12 Service at 1001 Front St - Tsunami Siren	0.46	False
450737	3/23/2026	412-111-4210-00000	ITEM 81 Service at 377 J St - City Hall	1.88	False
450737	3/23/2026	508-508-4210-00000	ITEM 34 Service at Garage Area Light - Shop	28.97	False
450737	3/23/2026	419-130-4210-00000	ITEM 81 Service at 377 J St - City Hall	6.61	False
450737	3/23/2026	413-114-4210-00000	ITEM 81 Service at 377 J St - City Hall	4.45	False
450737	3/23/2026	412-130-4210-00000	ITEM 12 Service at 1001 Front St - Tsunami Siren	0.09	False
450737	3/23/2026	413-352-4210-00000	ITEM 91 Service at 377 J St - Svc to Clock	0.52	False
450737	3/23/2026	419-371-4210-00000	ITEM 90 Service at Bertsch Es at MP51	31.03	False
450737	3/23/2026	001-471-4210-00000	ITEM 27 Service at 1001 Front St - Cultural Cntr	3,315.95	False
450737	3/23/2026	001-480-4210-00000	ITEM 81 Service at 377 J St - City Hall	9.47	False
450737	3/23/2026	001-364-4210-10023	ITEM 124 Service - Front & Play St- Streetlights	153.83	False
450737	3/23/2026	412-114-4210-00000	ITEM 12 Service at 1001 Front St - Tsunami Sire	0.05	False
450737	3/23/2026	413-111-4210-00000	ITEM 12 Service at 1001 Front St - Tsunami Siren	0.54	False
450737	3/23/2026	419-111-4210-00000	ITEM 12 Service at 1001 Front St - Tsunami Siren	0.60	False
450737	3/23/2026	001-364-4210-10023	ITEM 54 Service - Streetlights	110.67	False
450737	3/23/2026	001-230-4210-00000	ITEM 75 Service at 520 I St - Fire Hall	835.42	False
450737	3/23/2026	001-471-4210-00000	ITEM 81 Service at 377 J St - City Hall	8.63	False
450737	3/23/2026	001-470-4210-00000	ITEM 89 Service at Mall Ltg Antlers Tr - Parks	24.49	False

Check Numbe	Check Date	Acct 1	Description	Amount	Selected For Void
450737	3/23/2026	001-364-4210-00000	ITEM 12 Service at 1001 Front St - Tsunami Siren	0.60	False
450737	3/23/2026	419-113-4210-00000	ITEM 12 Service at 1001 Front St - Tsunami Siren	0.55	False
450737	3/23/2026	419-111-4210-00000	ITEM 81 Service at 377 J St - City Hall	12.45	False
450737	3/23/2026	420-115-4210-00000	ITEM 91 Service at 377 J St - Svc to Clock	7.04	False
450737	3/23/2026	001-364-4210-10023	ITEM 113 Service at Harding & Northcrest Lt	84.98	False
450737	3/23/2026	419-371-4210-00000	ITEM 58 Service at KingsValley Rd Off Hwy101	1,445.32	False
450737	3/23/2026	419-371-4210-00000	ITEM 43 Service at SE Cor E Wash & Burtschl Tank	2,105.42	False
450737	3/23/2026	001-364-4210-10023	ITEM 111 Service at1190 Breen- 2 flashing lights	21.50	False
450737	3/23/2026	412-100-4210-00000	ITEM 91 Service at 377 J St - Svc to Clock	0.88	False
450737	3/23/2026	001-364-4210-10023	ITEM 117 Service at ABT 270 US Hwy 101S- lights	148.84	False
450737	3/23/2026	419-113-4210-00000	ITEM 91 Service at 377 J St - Svc to Clock	1.07	False
450737	3/23/2026	001-251-4210-00000	ITEM 12 Service at 1001 Front St - Tsunami Siren	2.92	False
450737	3/23/2026	413-353-4210-00000	ITEM 109 Service at Pacific & El Dorado	21.50	False
450737	3/23/2026	413-357-4210-00000	ITEM 12 Service at 1001 Front St - Tsunami Siren	1.06	False
450737	3/23/2026	001-470-4210-00000	ITEM 84 Service at SW Cor G/Front St Park	180.24	False
450737	3/23/2026	413-114-4210-00000	ITEM 12 Service at 1001 Front St - Tsunami Siren	0.22	False
450737	3/23/2026	001-113-4210-00000	ITEM 81 Service at 377 J St - City Hall	11.48	False
450737	3/23/2026	419-113-4210-00000	ITEM 81 Service at 377 J St - City Hall	11.48	False
450737	3/23/2026	419-114-4210-00000	ITEM 81 Service at 377 J St - City Hall	5.21	False
450737	3/23/2026	419-371-4210-00000	ITEM 104 Service at 510 E Cooper Ave	22.31	False
450737	3/23/2026	413-130-4210-00000	ITEM 91 Service at 377 J St - Svc to Clock	0.62	False
450738	3/23/2026	508-508-4320-00000	Reimbursement for protective prescription eyeglasses.	200.00	False
450739	3/23/2026	001-470-4230-00000	Alarm System for Beachfront storage shed April- June.	92.97	False
450739	3/23/2026	001-240-4450-00000	Alarm System for PD April- June	119.97	False
450739	3/23/2026	506-506-4230-00000	Alarm System for Corp yard July- June	371.88	False
450739	3/23/2026	001-240-4450-00000	Alarm System for PD Jan- March	119.97	False
450739	3/23/2026	413-351-4230-00000	Alarm System for WWTP April- June.	119.97	False
450740	3/23/2026	001-350-4311-00000	Boot reimbursement FY 26	200.00	False
450741	3/23/2026	001-470-4450-00000	Irrigation Consultation.	925.00	False
450742	3/23/2026	412-000-3570-00000	REFUND for stay on 03/12-03/14/26 Con# 13092	36.36	False
450742	3/23/2026	001-000-3221-00000	REFUND for stay on 03/12-03/14/26 Con# 13092	3.64	False
450743	3/23/2026	413-120-4415-00000	Online & IVR Utlity payment processing. Feb 2026	1,388.40	False
450743	3/23/2026	419-120-4415-00000	Online & IVR Utlity payment processing. Feb 2026	1,388.40	False
450744	3/23/2026	001-000-3221-00000	REFUND for stay on 07/21-07/23/26 Con# 13283	5.00	False
450744	3/23/2026	412-000-3570-00000	REFUND for stay on 07/21-07/23/26 Con# 13283	50.00	False
450745	3/23/2026	001-114-4409-00000	FY26 Safety training: Bloodborne path 1 yr certs.	149.50	False
450745	3/23/2026	001-114-4409-00000	FY26 Safety training: Online respiratory training.	224.00	False
450745	3/23/2026	001-114-4409-00000	FY26 Safety training: Intro to Cal/OSHA; IIPP	30.00	False
450745	3/23/2026	001-114-4409-00000	FY26 Safety training: Intro to Cal/OSHA; IIPP	45.00	False
450745	3/23/2026	001-114-4409-00000	FY26 Safety training: Online workplace violence prevention.	24.00	False
450745	3/23/2026	001-114-4409-00000	FY26 Safety training: Basic life support- initial and renewal.	450.00	False
450745	3/23/2026	001-114-4409-00000	FY26 Safety training: Fit test	50.00	False
450745	3/23/2026	001-114-4409-00000	FY26 Safety training: Online workplace violence prevention.	36.00	False

Check Numbe	Check Date	Acct 1	Description	Amount	Selected For Void
450745	3/23/2026	001-114-4409-00000	FY26 Safety training: Reporting, documenting, meetings.	777.00	False
450745	3/23/2026	001-114-4409-00000	FY26 Safety training: In person respiratory training.	684.00	False
450746	3/23/2026	412-100-4310-00000	Office supplies	59.20	False
450746	3/23/2026	901-470-4799-47012	Coastal commission's plans.	512.02	False
450746	3/23/2026	901-470-4799-47012	Coastal commission's plans.	512.02	False
450747	3/23/2026	117-364-4409-003ST	3rd Street Topographic Survey	31.00	False
450747	3/23/2026	117-364-4409-00KST	K Street reconstruction design	2,576.75	False
450747	3/23/2026	117-364-4409-00KST	K Street reconstruction design	74.50	False
450747	3/23/2026	419-372-4409-41029	TO5 Meadowbrook Water Model	1,182.00	False
450747	3/23/2026	117-364-4409-00KST	K Street reconstruction design	310.00	False
450748	3/23/2026	901-470-4799-TLCL2	Lithomosiac TCC Art Elements: small basket and pebble mosaics.	11,270.00	False
450749	3/23/2026	001-240-4450-00000	Maintenance of copier at PD. 03/01-03/31/26	63.85	False
450750	3/23/2026	001-364-4390-10025	Sweeper parts	869.18	False
450751	3/23/2026	001-470-4390-00000	SWIINGSETMALL: Swing set parts.	769.58	False
450751	3/23/2026	001-112-4530-00000	NORTH EDGE:11/5-11/7/25-Lakeport Econo Summit-Lacey-Reg	75.00	False
450751	3/23/2026	001-470-4390-00000	TRACTOR SUPPLY: Hinges.	42.19	False
450751	3/23/2026	508-508-4530-00000	HTL-5/3-5/8/26-Fire Equip Cert-Huffman-Lodging	1,094.19	False
450751	3/23/2026	419-112-4530-00000	NORTH EDGE:11/5-11/7/25-Lakeport Econo Summit-Lacey-Reg	37.50	False
450751	3/23/2026	413-112-4530-00000	NORTH EDGE:11/5-11/7/25-Lakeport Econo Summit-Lacey-Reg	37.50	False
450751	3/23/2026	001-470-4390-00000	SIGO SIGNS: Signs.	116.72	False
450751	3/23/2026	001-470-4390-00000	TRACTOR SUPPLY: Hinges	73.56	False
450751	3/23/2026	508-508-4530-00000	BOOKINGS-5/3-5/8/26-Fire Equip Cert-Huffman-Lodging fee	17.99	False
450752	3/23/2026	412-000-3570-00000	REFUND for stay on 02/05-02/28/26. Con # 13241	89.28	False
450752	3/23/2026	001-000-3221-00000	REFUND for stay on 02/05-02/28/26. Con # 13241	8.93	False
450753	3/23/2026	001-470-4390-00000	Powder coating	450.00	False
450754	3/23/2026	413-353-4530-00000	2/24-2/28/26 Monterey, CA- PW Conference - meals, fuel FINAL	52.02	False
450754	3/23/2026	001-350-4530-00000	2/24-2/28/26 Monterey, CA- PW Conference - meals, fuel FINAL	52.04	False
450754	3/23/2026	419-371-4530-00000	2/24-2/28/26 Monterey, CA- PW Conference - meals, fuel FINAL	52.02	False
450755	3/30/2026	610-000-2170-00000	PR Batch 00002.03.2026 Child Support-CA	88.84	False
450756	3/30/2026	610-000-2184-00000	PR Batch 00022.03.2026 CCEA Monthly Dues	5.00	False
450756	3/30/2026	610-000-2184-00000	PR Batch 00002.03.2026 CCEA Monthly Dues	80.00	False
450757	3/30/2026	610-000-2181-00000	PR Batch 00022.03.2026 CCPOA Dues	600.00	False
450758	3/30/2026	610-000-2178-00000	Plan # 300878	194.48	False
450758	3/30/2026	610-000-2186-00000	Plan # 306752	229.57	False
450758	3/30/2026	610-000-2186-00000	Plan # 306752	38.58	False
450758	3/30/2026	610-000-2186-00000	Plan # 306752	2.67	False
450758	3/30/2026	610-000-2186-00000	Plan # 306752	12.75	False
450758	3/30/2026	610-000-2178-00000	Plan # 300878	335.00	False
450758	3/30/2026	610-000-2186-00000	Plan # 306752	8.09	False
450758	3/30/2026	610-000-2178-00000	Plan # 300878	300.19	False
450758	3/30/2026	610-000-2186-00000	Plan # 306752	1,094.78	False
450758	3/30/2026	610-000-2178-00000	Plan # 300878	2,075.00	False
450759	3/30/2026	610-000-2182-00000	PR Batch 00022.03.2026 PORAC RMT 4850	50.00	False

Check Numbe	Check Date	Acct 1	Description	Amount	Selected For Void
450759	3/30/2026	610-000-2182-00000	PR Batch 00022.03.2026 PORAC RMT	550.00	False
450760	3/30/2026	159-485-4799-23ASP	Front Street CDBG labor compliance. Prog pmnt no. 6	3,000.00	False
450761	3/30/2026	413-120-4310-00000	CH -Office Supplies	1.33	False
450761	3/30/2026	412-120-4310-00000	CH -Office Supplies	0.43	False
450761	3/30/2026	001-471-4310-00000	CH -Office Supplies	0.17	False
450761	3/30/2026	420-115-4310-00000	CH -Office Supplies	3.17	False
450761	3/30/2026	412-111-4310-00000	CH -Office Supplies	0.04	False
450761	3/30/2026	001-364-4310-00000	CH -Office Supplies	0.25	False
450761	3/30/2026	001-111-4310-00000	CH -Office Supplies	0.24	False
450761	3/30/2026	419-113-4310-00000	Frame for hallway photo.	5.20	False
450761	3/30/2026	413-353-4310-00000	CH -Office Supplies	0.53	False
450761	3/30/2026	001-112-4310-00000	CH -Office Supplies	0.51	False
450761	3/30/2026	413-114-4310-00000	CH -Office Supplies	0.19	False
450761	3/30/2026	001-350-4310-00000	CH -Office Supplies	1.32	False
450761	3/30/2026	001-114-4310-00000	CH -Office Supplies	0.54	False
450761	3/30/2026	001-364-4310-00000	CH -Office Supplies	0.53	False
450761	3/30/2026	001-470-4310-00000	CH -Office Supplies	0.09	False
450761	3/30/2026	419-111-4310-00000	CH -Office Supplies	0.25	False
450761	3/30/2026	001-313-4310-00000	Toner	79.16	False
450761	3/30/2026	412-100-4310-00000	CH -Office Supplies	0.19	False
450761	3/30/2026	412-114-4310-00000	CH -Office Supplies	0.02	False
450761	3/30/2026	412-113-4310-00000	Frame for hallway photo.	0.65	False
450761	3/30/2026	413-111-4310-00000	CH -Office Supplies	0.22	False
450761	3/30/2026	412-111-4310-00000	CH -Office Supplies	0.08	False
450761	3/30/2026	419-114-4310-00000	CH -Office Supplies	0.22	False
450761	3/30/2026	001-480-4310-00000	CH -Office Supplies	0.40	False
450761	3/30/2026	413-357-4310-00000	CH -Office Supplies	0.92	False
450761	3/30/2026	419-371-4310-00000	Toner	79.16	False
450761	3/30/2026	001-313-4310-00000	CH -Office Supplies	0.32	False
450761	3/30/2026	413-130-4310-00000	CH -Office Supplies	0.28	False
450761	3/30/2026	001-130-4310-00000	CH -Office Supplies	0.55	False
450761	3/30/2026	419-120-4310-00000	CH -Office Supplies	2.80	False
450761	3/30/2026	412-120-4310-00000	CH -Office Supplies	0.21	False
450761	3/30/2026	001-113-4310-00000	CH -Office Supplies	0.23	False
450761	3/30/2026	413-353-4310-00000	Toner	79.16	False
450761	3/30/2026	412-113-4310-00000	CH -Office Supplies	0.06	False
450761	3/30/2026	001-240-4390-00000	Evidence supplies.	259.80	False
450761	3/30/2026	001-364-4310-00000	Toner	79.16	False
450761	3/30/2026	419-371-4310-00000	CH -Office Supplies	1.69	False
450761	3/30/2026	001-114-4310-00000	CH -Office Supplies	1.13	False
450761	3/30/2026	413-114-4310-00000	CH -Office Supplies	0.09	False
450761	3/30/2026	420-115-4310-00000	CH -Office Supplies	1.51	False
450761	3/30/2026	419-114-4310-00000	CH -Office Supplies	0.10	False

Check Numbe	Check Date	Acct 1	Description	Amount	Selected For Void
450761	3/30/2026	001-112-4310-00000	CH -Office Supplies	1.08	False
450761	3/30/2026	419-120-4310-00000	CH -Office Supplies	1.33	False
450761	3/30/2026	413-113-4310-00000	Frame for hallway photo.	5.19	False
450761	3/30/2026	419-130-4310-00000	CH -Office Supplies	0.27	False
450761	3/30/2026	419-130-4310-00000	CH -Office Supplies	0.13	False
450761	3/30/2026	001-350-4310-00000	CH -Office Supplies	0.62	False
450761	3/30/2026	001-250-4310-00000	CH -Office Supplies	0.27	False
450761	3/30/2026	413-357-4310-00000	CH -Office Supplies	0.44	False
450761	3/30/2026	419-111-4310-00000	CH -Office Supplies	0.52	False
450761	3/30/2026	412-130-4310-00000	CH -Office Supplies	0.08	False
450761	3/30/2026	001-120-4310-00000	CH -Office Supplies	1.24	False
450761	3/30/2026	413-130-4310-00000	CH -Office Supplies	0.13	False
450761	3/30/2026	001-251-4310-00000	CH -Office Supplies	1.22	False
450761	3/30/2026	412-114-4310-00000	CH -Office Supplies	0.04	False
450761	3/30/2026	001-470-4390-00000	Basketball nets.	97.40	False
450761	3/30/2026	001-111-4310-00000	CH -Office Supplies	0.51	False
450761	3/30/2026	419-371-4310-00000	CH -Office Supplies	0.80	False
450761	3/30/2026	001-470-4310-00000	CH -Office Supplies	0.19	False
450761	3/30/2026	001-250-4310-00000	CH -Office Supplies	0.58	False
450761	3/30/2026	413-113-4310-00000	CH -Office Supplies	0.48	False
450761	3/30/2026	001-113-4310-00000	CH -Office Supplies	0.48	False
450761	3/30/2026	413-113-4310-00000	CH -Office Supplies	0.23	False
450761	3/30/2026	001-471-4310-00000	CH -Office Supplies	0.36	False
450761	3/30/2026	413-352-4310-00000	CH -Office Supplies	0.11	False
450761	3/30/2026	001-130-4310-00000	CH -Office Supplies	0.26	False
450761	3/30/2026	001-313-4310-00000	CH -Office Supplies	0.67	False
450761	3/30/2026	001-350-4310-00000	Folders.	7.57	False
450761	3/30/2026	412-130-4310-00000	CH -Office Supplies	0.04	False
450761	3/30/2026	413-352-4310-00000	CH -Office Supplies	0.24	False
450761	3/30/2026	419-113-4310-00000	CH -Office Supplies	0.48	False
450761	3/30/2026	413-353-4310-00000	CH -Office Supplies	0.25	False
450761	3/30/2026	508-508-4390-00000	Filter.	114.02	False
450761	3/30/2026	412-100-4310-00000	CH -Office Supplies	0.40	False
450761	3/30/2026	001-240-4390-00000	Filters	87.93	False
450761	3/30/2026	001-113-4310-00000	Frame for hallway photo.	5.19	False
450761	3/30/2026	001-251-4310-00000	CH -Office Supplies	2.56	False
450761	3/30/2026	413-120-4310-00000	CH -Office Supplies	2.82	False
450761	3/30/2026	001-480-4310-00000	CH -Office Supplies	0.19	False
450761	3/30/2026	508-508-4310-00000	Toner	79.16	False
450761	3/30/2026	001-470-4310-00000	Toner	79.16	False
450761	3/30/2026	412-113-4310-00000	CH -Office Supplies	0.03	False
450761	3/30/2026	001-350-4310-00000	Toner	79.16	False
450761	3/30/2026	419-113-4310-00000	CH -Office Supplies	0.23	False

Check Numbe	Check Date	Acct 1	Description	Amount	Selected For Void
450761	3/30/2026	413-111-4310-00000	CH -Office Supplies	0.48	False
450761	3/30/2026	001-120-4310-00000	CH -Office Supplies	2.62	False
450762	3/30/2026	001-230-4220-00000	Propane fuel delivery and service fees: Delivery on 02/23/26	312.29	False
450763	3/30/2026	508-508-4390-60003	Guzzler	223.20	False
450764	3/30/2026	001-230-4550-00000	Membership dues	340.00	False
450765	3/30/2026	412-100-4390-00000	Power outlets.	97.31	False
450766	3/30/2026	001-470-4225-00000	Refuse Disposal- Feb 2026	58.45	False
450766	3/30/2026	001-364-4225-10025	Refuse Disposal- Feb 2026	104.05	False
450766	3/30/2026	412-100-4225-00000	Refuse Disposal- Feb 2026	107.45	False
450766	3/30/2026	506-506-4225-00000	Refuse Disposal- Feb 2026	212.60	False
450767	3/30/2026	001-230-4391-00000	Battery for old 5100	170.44	False
450767	3/30/2026	508-508-4390-00000	Core credit.	-27.06	False
450768	3/30/2026	001-480-4390-00000	Sleeve, thimble, cable.	80.53	False
450769	3/30/2026	001-240-4450-00000	Fire extinguisher maintenance	532.31	False
450770	3/30/2026	001-364-4390-10025	Safety/PW Supplies	152.80	False
450770	3/30/2026	001-470-4390-00000	Safety/PW Supplies	13.42	False
450770	3/30/2026	508-508-4390-00000	Safety/PW Supplies	152.71	False
450770	3/30/2026	508-508-4390-00000	Safety/PW Supplies	13.42	False
450770	3/30/2026	506-506-4390-00000	Safety/PW Supplies	152.81	False
450770	3/30/2026	001-364-4390-10025	Safety/PW Supplies	13.43	False
450770	3/30/2026	413-353-4390-00000	Safety/PW Supplies	13.42	False
450770	3/30/2026	413-353-4390-00000	Safety/PW Supplies	152.80	False
450770	3/30/2026	506-506-4390-00000	Safety/PW Supplies	13.43	False
450770	3/30/2026	001-470-4390-00000	Safety/PW Supplies	152.71	False
450770	3/30/2026	419-371-4390-00000	Safety/PW Supplies	152.80	False
450770	3/30/2026	419-371-4390-00000	Safety/PW Supplies	13.43	False
450771	3/30/2026	413-353-4390-00000	V belt	104.70	False
450771	3/30/2026	001-230-4391-00000	Spark plug wire set	-135.86	False
450771	3/30/2026	508-508-4390-00000	Drain plug	5.12	False
450771	3/30/2026	508-508-4390-00000	Shift tube	56.20	False
450771	3/30/2026	508-508-4390-00000	Bay boxes	199.98	False
450771	3/30/2026	508-508-4390-60001	Drain plug	5.12	False
450771	3/30/2026	508-508-4390-00000	Battery	158.48	False
450771	3/30/2026	508-508-4390-00000	Washer pump	18.92	False
450771	3/30/2026	001-240-4391-00000	Chevy tahoe part	29.16	False
450771	3/30/2026	001-230-4391-00000	Hose clamp	2.21	False
450771	3/30/2026	001-230-4391-00000	Spark plug	212.69	False
450771	3/30/2026	001-230-4391-00000	Hose	111.52	False
450771	3/30/2026	001-240-4391-00000	Engine oil filer	5.51	False
450771	3/30/2026	001-230-4391-00000	Wire set, air intake cleaner	142.91	False
450771	3/30/2026	001-230-4391-00000	V belt	62.30	False
450771	3/30/2026	508-508-4390-00000	Core Deposit	-19.49	False
450771	3/30/2026	508-508-4390-00000	Air filter	16.70	False

Check Numbe	Check Date	Acct 1	Description	Amount	Selected For Void
450771	3/30/2026	508-508-4390-00000	Cutting fluid	135.03	False
450771	3/30/2026	508-508-4390-60001	Hood lift support	63.24	False
450771	3/30/2026	508-508-4390-60001	Defrost activator	31.62	False
450771	3/30/2026	508-508-4390-60001	Bay boxes	199.98	False
450771	3/30/2026	508-508-4390-00000	Bay boxes	211.06	False
450772	3/30/2026	419-000-2110-00000	REISSUANCE of ck# 449297: Refund Check 109389-000, 485 J ST #B	304.66	False
450773	3/30/2026	508-508-4390-00000	Parts	94.35	False
450773	3/30/2026	001-230-4391-00000	Apparatus repair part (brush head)	37.83	False
450773	3/30/2026	001-240-4390-00000	Parts	185.74	False
450773	3/30/2026	001-230-4390-00000	Light bulb and housing.	8.61	False
450773	3/30/2026	508-508-4390-00000	Light bulb and housing.	34.31	False
450773	3/30/2026	506-506-4390-00000	Parts	49.85	False
450774	3/30/2026	001-000-3221-00000	REFUND for stay on 03/25-03/29/26 Con # 13546	3.64	False
450774	3/30/2026	412-000-3570-00000	REFUND for stay on 03/25-03/29/26 Con # 13546	36.36	False
450775	3/30/2026	001-470-4390-00000	Bench chain vise.	153.13	False
450775	3/30/2026	001-364-4390-10025	Bench chain vise.	153.13	False
450775	3/30/2026	413-353-4390-00000	Bench chain vise.	153.13	False
450775	3/30/2026	001-364-4390-10025	Turnlock	635.00	False
450775	3/30/2026	419-371-4390-00000	Bench chain vise.	153.13	False
450776	3/30/2026	413-000-1202-00000	Sludge processing.	2,295.02	False
450777	3/30/2026	419-000-3741-00000	REFUND: Water and sewer connection fees.	2,700.00	False
450777	3/30/2026	419-000-3731-00000	REFUND: Water and sewer connection fees.	800.38	False
450777	3/30/2026	413-000-3742-00000	REFUND: Water and sewer connection fees.	9,682.00	False
450778	3/30/2026	001-470-4390-00000	Steel	116.01	False
450779	3/30/2026	001-230-4391-00000	Parts to repair 5111 after collision	2,020.91	False
450779	3/30/2026	001-230-4391-00000	Parts to repair 5111 after collision	830.40	False
450780	3/30/2026	001-480-4430-00000	KPOD Radio Spots: Feb 2026	70.00	False
450780	3/30/2026	001-480-4430-00000	KPOD Radio Spots: Feb 2026	70.00	False
450780	3/30/2026	412-100-4430-00000	KPOD Radio Spots: Feb 2026	33.00	False
450780	3/30/2026	412-100-4430-00000	KPOD Radio Spots: Feb 2026	33.00	False
450780	3/30/2026	001-112-4430-00000	KPOD Radio Spots: Feb 2026	47.00	False
450780	3/30/2026	001-112-4430-00000	KPOD Radio Spots: Feb 2026	47.00	False
450780	3/30/2026	001-112-4430-00000	KPOD Radio Spots: Feb 2026	47.00	False
450780	3/30/2026	412-100-4430-00000	KPOD Radio Spots: Feb 2026	33.00	False
450780	3/30/2026	001-480-4430-00000	KPOD Radio Spots: Feb 2026	70.00	False
450781	3/30/2026	001-230-4396-00000	Multiglass Detector kit, Calibration Cylinder & Multi-flow Calib	4,645.50	False
450782	3/30/2026	508-508-4390-00000	Tires.	38.97	False
450783	3/30/2026	413-352-4470-00000	FY26 External testing for WWTP	1,401.50	False
450784	3/30/2026	508-508-4320-00000	FY 26 Laundry services/uniforms	35.33	False
450784	3/30/2026	508-508-4320-00000	FY 26 Laundry services/uniforms	35.33	False
450784	3/30/2026	413-351-4320-00000	FY 26 Laundry services/uniforms	18.56	False
450784	3/30/2026	413-353-4320-00000	FY 26 Laundry services/uniforms	54.14	False
450784	3/30/2026	001-480-4370-00000	FY 26 Laundry services	72.48	False

Check Numbe	Check Date	Acct 1	Description	Amount	Selected For Void
450784	3/30/2026	413-353-4320-00000	FY 26 Laundry services/uniforms	54.14	False
450785	3/30/2026	412-100-4799-COAST	Asbestos abatement Lighthouse Cove	9,900.00	False
450786	3/30/2026	001-240-4391-00000	Battery	240.14	False
450786	3/30/2026	001-240-4391-00000	Core return	-22.00	False
450787	3/30/2026	001-470-4390-00000	4" reduced pressure backflow device and parts for Beach Front Pa	2,153.87	False
450788	3/30/2026	001-230-4370-00000	Cleaning supplies	157.83	False
450789	3/30/2026	508-508-4390-00000	Lift Pump Kit and washers for street sweeper #32	1,126.91	False
450790	3/30/2026	001-230-4451-00000	Fire alarm monitoring service: April-June	143.97	False
450791	3/30/2026	506-506-4390-00000	Garage door.	950.00	False
450792	3/30/2026	001-230-4530-00000	Online courses for Fire Staff	2,492.00	False
450793	3/30/2026	001-114-4409-00000	FY26 Safety training: CPR/ AED First aid.	406.00	False
450794	3/30/2026	001-240-4391-00000	Tires	960.00	False
450795	3/30/2026	001-120-4310-00000	QUILL: File jackets.	39.83	False
450795	3/30/2026	508-508-4390-00000	ELKL VALLEY: Propane.	48.45	False
450795	3/30/2026	413-352-4470-00000	MAILROOM: Wastewater shipping.	110.30	False
450795	3/30/2026	419-371-4390-00000	MAILROOM: Technical system shipment.	15.21	False
450795	3/30/2026	413-353-4390-00000	HARBOR FREIGHT: Wrenches & sockets	120.13	False
450795	3/30/2026	419-371-4530-00000	CHEVRON:2/17-2/18/26-Redding,CA-Drinking H2o Dist Grd 2: Fuel	21.84	False
450795	3/30/2026	413-352-4470-00000	Safeway: Wastewater shipping	4.86	False
450795	3/30/2026	419-120-4310-00000	QUILL: File jackets.	39.84	False
450795	3/30/2026	419-371-4530-00000	SHELL:2/17-2/18/26-Redding,CA-Drinking H2o Dist Grd 2: Fuel	49.80	False
450795	3/30/2026	419-371-4550-00000	CA WATER ENVIR: CWEA Elect grade2	59.50	False
450795	3/30/2026	419-371-4530-00000	SHASTA COLL_:2/17-2/18/26-Redding,CA-Drinking H2o Dist Grd 2	2.00	False
450795	3/30/2026	419-371-4530-00000	HOLIDAY:2/17-2/18/26-Redding,CA-Drinking H2o Dist Grd 2: Lodging	210.94	False
450795	3/30/2026	419-371-4530-00000	CA WATER ENVIR-3/8-3/14/26 -Sac, Backflow Course/test-McAleenan-	1,465.00	False
450795	3/30/2026	001-251-4550-00000	INTL' CODE COUNCIL: Code book tabs.	96.88	False
450795	3/30/2026	413-353-4550-00000	CA WATER ENVIR: CWEA Elect grade2	59.50	False
450795	3/30/2026	419-371-4530-00000	BOOKING:2/17-2/18/26-Redding,CA-Drinking H2o Dist Grd 2: Lodging	17.99	False
450795	3/30/2026	413-351-4550-00000	CA WATER ENVIR: CWEA Renewal	119.00	False
450795	3/30/2026	413-120-4310-00000	QUILL: File jackets.	39.83	False
450796	3/30/2026	419-120-4230-00000	707-457-0842 UB Auto Receptionist	11.26	False
450796	3/30/2026	001-240-4230-00000	707-951-5023 (Phillippa) Service:	18.03	False
450796	3/30/2026	419-120-4230-00000	707-951-3930 (Water/Sewer UB Line) Sevice:	14.09	False
450796	3/30/2026	413-120-4230-00000	707-951-3907 (Cash Receipting) Service:	9.40	False
450796	3/30/2026	001-240-4230-00000	707-951-3152 (Lo) Service:	18.03	False
450796	3/30/2026	001-120-4230-00000	707-951-5834 Melissa Leeper	6.01	False
450796	3/30/2026	419-113-4230-00000	707-951-5239 Altman, Robin	5.77	False
450796	3/30/2026	001-251-4230-00000	707-951-5158 (Barbour) Service:	7.21	False
450796	3/30/2026	419-371-4230-00000	707-951-2627 (Van Hook) Service:	6.01	False
450796	3/30/2026	001-240-4230-00000	707-457-0891 Dash Cam	40.01	False
450796	3/30/2026	001-120-4230-00000	707-951-5342 Rawlings	6.01	False
450796	3/30/2026	419-120-4230-00000	707-951-3355 (Kozak) Service:	6.01	False
450796	3/30/2026	413-353-4230-00000	707-951-5179 Queen, J.	6.01	False

Check Numbe	Check Date	Acct 1	Description	Amount	Selected For Void
450796	3/30/2026	001-480-4230-00000	707-951-5192 Neeley	18.03	False
450796	3/30/2026	001-114-4230-00000	707-951-3392 HR LINE	44.55	False
450796	3/30/2026	506-506-4230-00000	707-951-6752 (Wylie)	7.00	False
450796	3/30/2026	001-240-4230-00000	707-951-5170 (Sperling) Service:	18.03	False
450796	3/30/2026	413-352-4230-00000	707-951-4779 (WWTP Project Manager) Service:	28.19	False
450796	3/30/2026	001-240-4230-00000	707-457-0890 Dash Cam	40.01	False
450796	3/30/2026	412-120-4230-00000	707-951-5644 Diane Swarts	0.85	False
450796	3/30/2026	001-111-4230-00000	707-951-9106 Admin Auto Receptionist	7.51	False
450796	3/30/2026	419-120-4230-00000	707-951-2294 SPMR Meter Reader	38.37	False
450796	3/30/2026	001-240-4230-00000	707-951-3960 (Griffin) Service:	28.19	False
450796	3/30/2026	413-111-4230-00000	707-951-9106 Admin Auto Receptionist	7.51	False
450796	3/30/2026	001-240-4230-00000	707-951-1988 (Aguirre) Service:	18.03	False
450796	3/30/2026	001-240-4230-00000	707-951-5300 Valero, Magnolia	18.03	False
450796	3/30/2026	001-350-4230-00000	707-951-5143 (Yeager) Service:	6.01	False
450796	3/30/2026	419-371-4230-00000	707-951-4116 (Amarante) Service:	23.60	False
450796	3/30/2026	413-111-4230-00000	707-951-3228 (Wier) Service:	6.01	False
450796	3/30/2026	413-351-4230-00000	707-951-9756 (Goodgame-Thill) Service:	28.19	False
450796	3/30/2026	419-111-4230-00000	707-951-9106 Admin Auto Receptionist	7.50	False
450796	3/30/2026	001-364-4230-00000	707-951-3904 Wade Mayes	3.95	False
450796	3/30/2026	001-480-4230-00000	707-951-1991 (Borges, D) Service	2.71	False
450796	3/30/2026	413-353-4230-00000	707-951-3904 Wade Mayes	5.92	False
450796	3/30/2026	001-240-4230-00000	707-457-0885 Dash Cam	40.05	False
450796	3/30/2026	419-371-4230-00000	707-951-6752 (Wylie)	34.37	False
450796	3/30/2026	001-113-4230-00000	707-951-5239 Altman, Robin	5.77	False
450796	3/30/2026	001-240-4230-00000	707-951-3963 (Hutchens) Service:	28.19	False
450796	3/30/2026	001-480-4230-00000	707-951-5193 W Morris	18.03	False
450796	3/30/2026	419-120-4230-00000	707-951-5342 Rawlings	6.01	False
450796	3/30/2026	413-120-4230-00000	707-951-5342 Rawlings	6.01	False
450796	3/30/2026	001-111-4230-00000	707-951-3898 (Conference Room) Service:	9.39	False
450796	3/30/2026	412-100-4230-00000	707-951-5194 Kelly Feola	5.41	False
450796	3/30/2026	001-111-4230-00000	707-951-3228 (Wier) Service:	6.01	False
450796	3/30/2026	001-240-4230-00000	707-457-0873 Dash Cam	40.01	False
450796	3/30/2026	412-114-4230-00000	707-951-3392 HR LINE	1.59	False
450796	3/30/2026	412-100-4230-00000	707-951-0023 Lighthouse Cove RV	28.19	False
450796	3/30/2026	001-230-4230-00000	707-951-3561 (Carey) Service:	38.01	False
450796	3/30/2026	001-350-4230-00000	707-951-5179 Queen, J.	6.01	False
450796	3/30/2026	001-230-4230-00000	707-464-9113 (Fire Hall) Service:	28.19	False
450796	3/30/2026	001-240-4230-00000	707-951-1958 (Wilson) Service:	18.03	False
450796	3/30/2026	001-120-4230-00000	707-951-3355 (Kozak) Service:	6.01	False
450796	3/30/2026	001-240-4230-00000	707-951-5326 C. Maxwell	18.03	False
450796	3/30/2026	001-350-4230-00000	707-951-2627 (Van Hook) Service:	6.01	False
450796	3/30/2026	001-480-4230-00000	707-457-0732 Fred Endert Pool	22.52	False
450796	3/30/2026	001-240-4230-00000	707-951-5205 Turkins	18.03	False

Check Numbe	Check Date	Acct 1	Description	Amount	Selected For Void
450796	3/30/2026	001-480-4230-00000	707-951-3921 (Pool Front Counter) Service:	28.19	False
450796	3/30/2026	508-508-4230-00000	707-951-5080 Camper	18.03	False
450796	3/30/2026	413-353-4230-00000	707-951-0167 (WWTP Ops) Service:	28.19	False
450796	3/30/2026	419-120-4230-00000	707-951-5834 Melissa Leeper	6.01	False
450796	3/30/2026	001-240-4230-00000	707-951-3471 (Miller) Service:	18.03	False
450796	3/30/2026	413-112-4230-00000	707-951-1975 (Lacey) Service:	4.81	False
450796	3/30/2026	001-364-4230-00000	707-951-6752 (Wylie)	8.91	False
450796	3/30/2026	419-111-4230-00000	707-951-3228 (Wier) Service:	6.01	False
450796	3/30/2026	419-371-4230-00000	707-951-9082 PW Auto Receptionist	7.51	False
450796	3/30/2026	413-353-4230-00000	707-951-3927 (Welton) Service:	9.40	False
450796	3/30/2026	001-112-4230-00000	707-951-1975 (Lacey) Service:	8.40	False
450796	3/30/2026	001-112-4230-00000	707-951-5194 Kelly Feola	4.51	False
450796	3/30/2026	413-352-4230-00000	707-951-5005 WWTP Auto Recept - Fritz	22.52	False
450796	3/30/2026	001-240-4230-00000	707-457-0870 Dash Cam	40.01	False
450796	3/30/2026	413-120-4230-00000	707-951-5834 Melissa Leeper	6.01	False
450796	3/30/2026	413-352-4230-00000	707-951-0002 (WWTP Lg Conf Rm) Service:	28.19	False
450796	3/30/2026	001-250-4230-00000	707-951-5158 (Barbour) Service:	1.80	False
450796	3/30/2026	001-120-4230-00000	707-951-3907 (Cash Receipting) Service:	9.40	False
450796	3/30/2026	412-113-4230-00000	707-951-5239 Altman, Robin	0.72	False
450796	3/30/2026	420-115-4230-00000	707-951-1613 IT Use	18.03	False
450796	3/30/2026	419-371-4230-00000	707-951-5143 (Yeager) Service:	6.01	False
450796	3/30/2026	001-240-4230-00000	707-951-1946 (Lopez) Service:	18.03	False
450796	3/30/2026	001-480-4230-00000	707-951-3962 (A Garcia) Service:	28.19	False
450796	3/30/2026	001-120-4230-00000	707-951-5054 (Leaver) Service:	6.01	False
450796	3/30/2026	001-364-4230-00000	707-951-4116 (Amarante) Service:	2.95	False
450796	3/30/2026	001-230-4230-00000	707-951-5234 Bill Gillespie	18.03	False
450796	3/30/2026	419-112-4230-00000	707-951-1975 (Lacey) Service:	4.82	False
450796	3/30/2026	419-111-4230-00000	707-951-3898 (Conference Room) Service:	9.40	False
450796	3/30/2026	413-120-4230-00000	707-457-0842 UB Auto Receptionist	11.26	False
450796	3/30/2026	413-353-4230-00000	707-951-4116 (Amarante) Service:	8.86	False
450796	3/30/2026	413-114-4230-00000	707-951-3392 HR LINE	6.81	False
450796	3/30/2026	419-371-4230-00000	707-951-3927 (Welton) Service:	9.39	False
450796	3/30/2026	508-508-4230-00000	707-951-3928 (Huffman) Service	28.19	False
450796	3/30/2026	413-353-4230-00000	707-951-2627 (Van Hook) Service:	6.01	False
450796	3/30/2026	413-353-4230-00000	707-951-3943 (Martinez) Service:	1.13	False
450796	3/30/2026	419-120-4230-00000	707-951-5644 Diane Swarts	4.04	False
450796	3/30/2026	413-120-4230-00000	707-951-5644 Diane Swarts	3.91	False
450796	3/30/2026	001-230-4230-00000	707-951-5356 Vanessa Duncan	18.03	False
450796	3/30/2026	419-114-4230-00000	707-951-3392 HR LINE	7.51	False
450796	3/30/2026	413-352-4230-00000	707-951-6681 (WWTP) - Fritz	22.52	False
450796	3/30/2026	413-120-4230-00000	707-951-5054 (Leaver) Service:	6.01	False
450796	3/30/2026	413-353-4230-00000	707-951-5143 (Yeager) Service:	6.01	False
450796	3/30/2026	413-353-4230-00000	707-951-3905 (WWTP Spare) Service:	1.13	False

Check Numbe	Check Date	Acct 1	Description	Amount	Selected For Void
450796	3/30/2026	413-353-4230-00000	707-951-9082 PW Auto Receptionist	7.50	False
450796	3/30/2026	412-100-4230-00000	707-951-9704 (Lighthouse Cove RV) Service:	28.19	False
450796	3/30/2026	413-352-4230-00000	707-951-5922 WWTP Auto Recept - Fritz	22.52	False
450796	3/30/2026	413-352-4230-00000	707-951-3294 WWTP Auto Recept - Fritz	22.52	False
450796	3/30/2026	419-120-4230-00000	707-951-5054 (Leaver) Service:	6.01	False
450796	3/30/2026	001-130-4230-00000	707-951-3063 (Rice) Service:	9.02	False
450796	3/30/2026	001-350-4230-00000	707-951-9082 PW Auto Receptionist	7.51	False
450796	3/30/2026	419-371-4230-00000	707-951-1991 (Borges, D) Service	8.47	False
450796	3/30/2026	413-113-4230-00000	707-951-5239 Altman, Robin	5.77	False
450796	3/30/2026	508-508-4230-00000	707-951-5305 Justin Phelan	18.03	False
450796	3/30/2026	413-120-4230-00000	707-951-3930 (Water/Sewer UB Line) Service:	14.10	False
450796	3/30/2026	506-506-4230-00000	707-951-3904 Wade Mayes	3.10	False
450796	3/30/2026	001-470-4230-00000	707-951-5194 Kelly Feola	2.35	False
450796	3/30/2026	413-353-4230-00000	707-951-6752 (Wylie)	13.36	False
450796	3/30/2026	508-508-4230-00000	707-951-3374 Corp Yard Auto Recept - Fritz	22.52	False
450796	3/30/2026	001-240-4230-00000	707-951-5115 (Pearson) Service:	18.03	False
450796	3/30/2026	413-351-4230-00000	707-951-6819 (Lab-Desk) Service:	28.19	False
450796	3/30/2026	413-120-4230-00000	707-951-3355 (Kozak) Service:	6.01	False
450796	3/30/2026	419-371-4230-00000	707-951-5179 Queen, J.	6.01	False
450796	3/30/2026	001-364-4230-00000	707-951-1991 (Borges, D) Service	4.15	False
450796	3/30/2026	001-471-4230-00000	707-951-5194 Kelly Feola	1.80	False
450796	3/30/2026	413-130-4230-00000	707-951-3063 (Rice) Service:	4.51	False
450796	3/30/2026	419-120-4230-00000	707-951-3907 (Cash Receipting) Service:	9.39	False
450796	3/30/2026	001-470-4230-00000	707-951-4116 (Amarante) Service:	2.96	False
450796	3/30/2026	001-240-4230-00000	707-457-7977 Police Auto Receptionist	22.52	False
450796	3/30/2026	420-115-4230-00000	707-951-1598 (Patch) Service	18.03	False
450796	3/30/2026	001-240-4230-00000	707-457-0866 Dash Cam	40.01	False
450796	3/30/2026	001-240-4230-00000	707-457-0877 Dash Cam	40.01	False
450796	3/30/2026	001-240-4230-00000	707-457-0867 Dash Cam	40.01	False
450796	3/30/2026	001-240-4230-00000	707-457-0884 Dash Cam	40.01	False
450796	3/30/2026	001-240-4230-00000	707-951-7001 (VIP Phone) Service:	1.13	False
450796	3/30/2026	419-130-4230-00000	707-951-3063 (Rice) Service:	4.50	False
450796	3/30/2026	413-111-4230-00000	707-951-3898 (Conference Room) Service:	9.40	False
450796	3/30/2026	413-352-4230-00000	707-951-3119 WWTP Auto Recept - Fritz	22.52	False
450796	3/30/2026	001-240-4230-00000	707-951-3150 (Sanders) Service:	18.03	False
450796	3/30/2026	413-352-4230-00000	707-951-6831 (WWTP) - Fritz	22.52	False
450796	3/30/2026	508-508-4230-00000	707-951-1991 (Borges, D) Service	2.70	False
450796	3/30/2026	001-350-4230-00000	707-951-3927 (Welton) Service:	9.40	False
450796	3/30/2026	001-480-4230-00000	707-951-5194 Kelly Feola	3.96	False
450796	3/30/2026	412-100-4230-00000	707-951-5029 (Lighthouse Cove RV) Service:	23.65	False
450796	3/30/2026	419-371-4230-00000	707-951-3904 Wade Mayes	15.22	False
450796	3/30/2026	001-240-4230-00000	707-951-5684 PD line	18.03	False
450796	3/30/2026	413-351-4230-00000	707-951-5017 (Lab) Service:	28.19	False

Check Numbe	Check Date	Acct 1	Description	Amount	Selected For Void
450796	3/30/2026	001-240-4230-00000	707-457-0881 Dash Cam	40.01	False
450796	3/30/2026	413-352-4230-00000	707-951-3105 WWTP Auto Receipt - Fritz	22.52	False
450796	3/30/2026	001-250-4230-00000	707-951-3288 (Minges) Service:	9.01	False
450796	3/30/2026	001-120-4230-00000	707-951-5644 Diane Swarts	8.82	False
450796	3/30/2026	001-240-4230-00000	707-458-5225 Dash Cam	40.01	False
450796	3/30/2026	413-351-4230-00000	707-951-0494 (Wood-Desk) Service:	28.19	False
450796	3/30/2026	413-351-4230-00000	707-951-6970 (Lab-Desk) Service:	28.19	False
450797	3/30/2026	413-353-4390-00000	Coaxial	3.62	False
450797	3/30/2026	508-508-4390-00000	Ball valves, pipe joints	241.12	False
450797	3/30/2026	001-470-4390-00000	Sparks screen	5.40	False
450797	3/30/2026	001-470-4390-00000	Drill bits	104.67	False
450797	3/30/2026	001-112-4390-00000	Screws, nuts and bolts	12.08	False
450797	3/30/2026	001-470-4390-00000	Shelf bracket, lumber	126.82	False
450797	3/30/2026	901-470-4799-47007	Lumber	96.69	False
450797	3/30/2026	508-508-4390-00000	Couplings	3.22	False
450797	3/30/2026	412-100-4799-COAST	Garbage disposal, lights	490.07	False
450797	3/30/2026	001-470-4390-00000	Tension bar	17.30	False
450797	3/30/2026	412-100-4799-COAST	Caulk, rod, floor quick	238.72	False
450797	3/30/2026	001-470-4390-00000	Bolts	30.18	False
450797	3/30/2026	419-371-4390-00000	Socket	6.38	False
450797	3/30/2026	419-371-4390-00000	lumber	358.21	False
450797	3/30/2026	001-364-4390-10025	Spray gun, parts	77.79	False
450797	3/30/2026	001-480-4390-00000	Screws, nuts and bolts	18.12	False
450797	3/30/2026	419-371-4390-00000	Water	5.94	False
450797	3/30/2026	001-364-4390-10025	Socket	6.37	False
450797	3/30/2026	506-506-4390-00000	Triflow	20.12	False
450797	3/30/2026	506-506-4390-00000	Parts	39.23	False
450797	3/30/2026	413-353-4390-00000	Can liner, screws, nuts and bolts	14.75	False
450797	3/30/2026	508-508-4390-00000	Coupling	11.26	False
450797	3/30/2026	508-508-4390-00000	Ball valve	216.50	False
450797	3/30/2026	001-470-4390-00000	Tube return	-195.19	False
450797	3/30/2026	001-230-4390-00000	Fuel	140.90	False
450797	3/30/2026	412-100-4799-COAST	Plywood	263.47	False
450797	3/30/2026	508-508-4390-60003	Part returns	-16.52	False
450797	3/30/2026	412-100-4799-COAST	Lumber	103.74	False
450797	3/30/2026	419-371-4390-00000	Can liner, screws, nuts and bolts	14.75	False
450797	3/30/2026	412-100-4799-COAST	Faucet return	-313.91	False
450797	3/30/2026	419-371-4390-00000	Parts	37.23	False
450797	3/30/2026	001-364-4390-10025	Can liner, screws, nuts and bolts	14.75	False
450797	3/30/2026	001-470-4390-00000	Tubes and couplings	215.31	False
450797	3/30/2026	412-100-4799-COAST	Keyblank, house key	15.28	False
450797	3/30/2026	413-353-4390-00000	Trailer	11.26	False
450797	3/30/2026	508-508-4390-60001	Adapters	9.05	False

Check Numbe	Check Date	Acct 1	Description	Amount	Selected For Void
450797	3/30/2026	001-480-4390-00000	Air filter	28.15	False
450797	3/30/2026	419-371-4390-00000	Blades, trowels	40.25	False
450797	3/30/2026	413-353-4390-00000	Organizer, screws, washers	154.98	False
450797	3/30/2026	506-506-4390-00000	Duct tape, sign, lumber	86.70	False
450797	3/30/2026	413-353-4390-00000	Socket	6.37	False
450797	3/30/2026	506-506-4390-00000	Key schlage, kwikset	42.15	False
450797	3/30/2026	001-240-4390-00000	Hinges	332.68	False
450797	3/30/2026	001-470-4390-00000	Trex	555.32	False
450797	3/30/2026	419-371-4390-00000	Lumber return	-191.74	False
450797	3/30/2026	412-100-4799-COAST	Lumber	4.71	False
450797	3/30/2026	001-470-4390-00000	Lumber	29.50	False
450797	3/30/2026	506-506-4390-00000	Posts	850.72	False
450797	3/30/2026	412-100-4390-00000	Key schlage	6.02	False
450797	3/30/2026	001-470-4390-00000	Tension bar	15.28	False
450798	3/30/2026	413-351-4530-00000	4/7-4/10/26 - Sacramento CWEA Conf - meals (PER DIEM)	245.10	False
				<hr/> <hr/>	
				307,647.09	
				<hr/> <hr/>	

AP  
03-21-26 to 04-03-26 Housing

User: kbates@crestedcity.org  
Printed: 4/7/2026 1:49:26 PM

REVIEWED  
kkozak , 4/7/2026, 3:54:22 PM



Check Date	Check Number	Description	Amount	Selected For Void
3/23/2026	450699	Misc Office Supplies- RETURN from invoice 1PY7-KQD6-NY1K.	-20.56	False
3/30/2026	450761	Misc Office Supplies: CREDIT for invoice# 1K47-91TN-FHVQ	-19.04	False
3/30/2026	450796	707-951-5644 Diane Swarts	0.41	False
3/23/2026	450699	Toner	1.38	False
3/23/2026	450699	Folders	1.77	False
3/30/2026	450796	707-951-3392 HR LINE	3.18	False
3/30/2026	450796	707-951-5158 (Barbour) Service:	9.02	False
3/30/2026	450796	707-951-3288 (Minges) Service:	9.02	False
3/30/2026	450761	Misc Office Supplies	14.64	False
3/30/2026	450796	707-464-9216 (HA Office) Service:	22.52	False
3/23/2026	450706	Copier Services FY25/26- 02/25-03/24/26	26.56	False
3/30/2026	450796	707-951-0710 (Miller) Service:	28.19	False
3/30/2026	450796	707-951-0909 (Hurt) Service:	28.19	False
3/30/2026	450796	707-951-0897 (Stover) Service:	28.19	False
3/30/2026	450796	707-951-0902 (Hartwick) Service:	28.19	False
3/23/2026	450706	Copier Services FY25/26: 01/25-02/24/26	31.27	False
3/23/2026	450737	ITEM 23 Service at 235 H St - HA	37.02	False
3/23/2026	450699	Misc Office Supplies	55.83	False
3/23/2026	450721	707-464-2692 HA Fax Line -03/01-03/29/26	173.99	False
3/23/2026	450699	Misc Office Supplies	191.17	False
3/23/2026	450737	ITEM 66 Service at 235 H St - HA	368.48	False
			<u>1,019.42</u>	



# CITY OF CRESCENT CITY

MAYOR ISAIAH WRIGHT  
COUNCIL MEMBER RAY ALTMAN  
COUNCIL MEMBER STEVE SHAMBLIN

MAYOR PRO TEM CANDACE TINKLER  
COUNCIL MEMBER JASON GREENOUGH

**MINUTES**  
**REGULAR MEETING OF THE**  
**CITY COUNCIL OF THE CITY OF CRESCENT CITY**  
FLYNN CENTER BOARD CHAMBERS  
981 H STREET  
CRESCENT CITY, CA 95531

**MONDAY**

**APRIL 6, 2026**

**6:00 P.M.**

**OPEN SESSION**

**Call to order** Mayor Wright called the meeting to order at 6:01 p.m.

**Roll call** Council Members present: Council Member Ray Altman, Council Member Jason Greenough, Council Member Steve Shamblin, Mayor Pro Tem Candace Tinkler, and Mayor Isaiah Wright  
Staff members present: City Manager Eric Wier, City Attorney Martha Rice, City Clerk/Administrative Analyst Robin Altman, IT/GIS Technician Taylor Patch, Economic Development and Grants Manager Bridget Lacey (via Zoom), Recreation Director and Events Coordinator Kelly Feola, Public Works Director Dave Yeager, Interim Aquatics Supervisor Rich Neely, Relief Pool Supervisor Hudson Williams, Finance Director Linda Leaver (via Zoom), and Police Chief Richard Griffin

**Pledge of Allegiance** led by Mayor Wright

**\*\*\*Moment of silence for Mike Young\*\*\***

City Manager Wier spoke about all of the work Mr. Young did around the world as well is in our community. Mr. Young started with the City as City Manager in the 1970s and continued working with the City in many capacities until 2017 when City Manager Wier started in his position. There were several projects Mr. Young worked on including opening Beachfront Park, Seawood Apartments, Pelican Bay State Prison’s water and wastewater systems and Rumiano Cheese lactose operation. Many City staff members were greatly impacted by Mr. Young.

Mayor Wright called for a moment of silence.

**CEREMONIAL ITEMS**

- **Introduction of New Employees – Interim Aquatics Supervisor Rich Neeley and Relief Supervisor Hudson Williams**

Recreation Director and Events Coordinator Feola introduced both Interim Aquatics Supervisor Rich Neeley and Relief Supervisor Hudson Williams to the Council.

- **Sexual Assault Awareness Month Proclamation**

Mayor Pro Tem Tinkler read the proclamation aloud; Mayor Wright presented the proclamation to Northcoast Rape Crisis Team Director Amanda LeBlanc. Director LeBlanc addressed the Council and went over the achievements of NCRCT this year. They recently received a grant that created a sexual assault forensic interview center. She spoke about needing community support as there is no funding for victim support in the proposed state budget and that is 50% of their budget. Mayor Wright stated he would like to see a letter of support for NCRCT for a future agenda.

- **Child Abuse Prevention Month Proclamation**

Council Member Shamblin read the proclamation aloud; Mayor Wright presented the signed proclamation to a member of the Child Abuse Prevention Council (CPAC). Sarah Caron addressed the City Council about the CAPC's commitment to ensure the safety of children in Del Norte. Melodee Mitchell invited the Council to the Children's Memorial Flag Raising ceremony this Thursday at 5pm at the Family Resource Center.

## **REPORTS AND PRESENTATIONS - None**

### **PUBLIC COMMENT PERIOD**

*The following residents addressed the Council:*

Mary Kwart, volunteer for the Bigfoot Trail Alliance: The trail starts in Red Bluff and ends at Battery Point Lighthouse. She would like the Council to write a letter of support for the Bigfoot Trail becoming a National Recreation Trail.

Gloria Carone: would like the Council to consider revising the current Parking Ordinance to prohibit RV parking on the street.

Brandon Bieber: stated that Del Norte County has a high volume of sex offenders. He would like to see more done than a proclamation for this issue.

Mark Bower: spoke about knowing Mike Young and that he was an incredible man. Spoke about a vehicle vs. bicyclist today and would like to see more attention to this as there are more e-bike riders in town. Spoke to RVs being parked all around town and that they are dumping in the street.

Cate Classen: spoke about over development in the downtown area and how can the WWTP be able to handle all of the new connections.

Doug Dye: would like no new development until it is known if the WWTP can handle it. He would also like parking to be addressed for the new development. Asked City Manager Wier if the rumor is true that Battery Point Apartments is a total loss and unsalvageable. City Manager Wier stated that was not true.

Sam Strait: would like to see Crescent City stay small and rural.

Donna Westfall: requested an agenda item to create an ad hoc committee to oversee any projects for the WWTP.

Margaret Sargent: stated she submitted a proposal via email about a 5-year plan for the City.

David Garcia: spoke in support of the Downtown Master Plan and offers his support of the developers' plan. Commends the Council's work towards the vibrancy of Downtown.

Shawna Hyatt: stated that the Planning Commission meeting videos on YouTube is categorized “for children”. She would like to see a limit to short-term rentals and the number of vacation rentals is a big reason why we have a problem with rentals. She would like an agenda item to develop a cap on them.

Mayor Wright asked Chief Griffin to speak on RVs and the electric bike accidents. Chief Griffin stated that they have received a report of one accident that involved an intoxicated person. For RVs, they are moved along, but they come back and there is nothing more CCPD can do about it. Stated a full ban on parking on the street would be unconstitutional, currently CCPD enforces any reported RVs parked in the street over 8 hours. He spoke in regards to CCPD’s action taken to handle sexual assault cases by using new technology they have acquired and they have been very active in solving those cases.

## **CONSENT CALENDAR**

### **1. Warrant Claims List**

- *Recommendation: Receive and file the warrant claims list for the period March 7, 2026 through March 20, 2026.*

### **2. Council Minutes**

- *Recommendation: Approve and adopt the March 16, 2026 minutes of the City Council of the City of Crescent City.*

### **3. Payroll Report**

- *Recommendation: Receive and file the biweekly payroll reports for the period ending March 21, 2026 paid March 27, 2026.*

### **4. Budget-to-Actual Summary as of February 28, 2026**

- *Recommendation: Receive and file budget-to-actual summary of the City’s major operating funds for Fiscal Year 2025-26 as of February 28, 2026*

### **5. Establishing a Reduced Fee for Planning Commission Review of Murals**

- *Recommendation: Approve and adopt Resolution No. 2026-24, A RESOLUTION OF THE CITY COUNCIL OF THE CITY OF CRESCENT CITY ESTABLISHING A REDUCED FEE FOR PLANNING COMMISSION REVIEW OF MURALS*

### **6. Front Street Gateway Project Stover Engineering Task Order 22 Amendment 3**

- *Recommendation: Authorize the City Manager to sign the Front Street Gateway Design Project Amendment 3 to Stover Engineering Task Order #22*

Sam Strait: is thankful the public showed up to the meeting. Spoke to item 6 and that the focus on Beachfront Park has been a priority of the Council.

Cate Classen: spoke about her concern with the gateway project and that it will make Crescent City “urban.”

Margaret Sargent: stated the City cannot afford the pay raises. She would like a focus on behavioral health. She would like murals around walkways.

Jody Mangum: spoke about the gateway on Front Street and high-rise apartments.

*On a motion by Council Member Greenough, seconded by Council Member Altman, and carried unanimously on a 5-0 polled vote, the City Council of the City of Crescent City adopted the consent calendar consisting of items 1-6 as presented.*

**PUBLIC HEARING - None**

**CONTINUING BUSINESS - None**

**NEW BUSINESS**

**7. Letter of Support for the Partnership for the Performing Arts**

- *Recommendation: Hear staff report*
- *Technical questions from the Council*
- *Receive public comment*
- *Further Council discussion*
- *Approve and authorize the City Council to sign a City/County joint letter of support for the Partnership for the Performing Arts Project for the Development of a Performing Arts Center in Del Norte County*

City Manager Wier reported to the Council that this item has been before the Council multiple times and this item is to continue the support of the PPA project. Michelle Carrillo of ThinkPlace was present to speak about the project to the Council. Mayor Pro Tem Tinkler spoke in support of the Performing Arts Center and the impacts the Rails have had on local children. Mayor Wright stated that the only instrument he was introduced to as a youth was the recorder, his son is now playing saxophone. Council Member Greenough thanked Nick Rail and the Foundation for all of the work done around the community.

Sam Strait: spoke about fundraising efforts in the County when his son was a child.

Donna Westfall: spoke in support of this project.

Brandon Bieber: spoke in support of this project.

Cate Classen: would prefer money spent on consultants to be spent toward this type of project.

Mayor Wright asked City Manager Wier how RFPs are put out for projects; City Manager Wier stated it depends on the grant and those requirements; however, they are put out as widely as possible.

Margaret Sargent: spoke in support of the project.

City Manager Wier stated that the project is reaching a critical stage. They are working with the Division of the State Architect (DSA) on the project details. It is almost complete and getting close to being shovel ready, however there are still big funding gaps. Ms. Carrillo addressed the Council and advised that construction would be late 2027 to early 2028. To donate to the project, visit the Partnership for Performing Arts website.

Linda Sutter: asked about the design of the project for tsunami evacuation use. Spoke in support of the project but doesn't want tax money used for it.

*On a motion by Council Member Greenough, seconded by Council Member Altman, and carried unanimously on a 5-0 polled vote, the City Council of the City of Crescent City approved and authorized the City Council to sign a City/County joint letter of support for the Partnership for the Performing Arts Project for the Development of a Performing Arts Center in Del Norte County.*

**8. Proposed Increases to Water Rates**

- *Recommendation: Hear staff report*
- *Technical questions from the Council*

- *Receive public comment*
- *Further Council discussion*
- *Waive full reading, read by title only and introduce Ordinance No. 862, AN ORDINANCE OF THE CITY COUNCIL OF THE CITY OF CRESCENT CITY AMENDING CHAPTER 13.16, WATER SERVICE RATES, OF TITLE 13, PUBLIC SERVICES, OF THE CRESCENT CITY MUNICIPAL CODE*
- *Approve and adopt Resolution No. 2026-25, A RESOLUTION OF THE CITY COUNCIL OF THE CITY OF CRESCENT CITY ADOPTING PROCEDURES FOR RECEIVING AND TABULATING PROTESTS AGAINST WATER RATE INCREASES UNDER PROPOSITION 218*
- *Approve and adopt Resolution No. 2026-26, A RESOLUTION OF THE CITY COUNCIL OF THE CITY OF CRESCENT CITY AMENDING THE FY 2025-26 BUDGET OF THE CITY OF CRESCENT CITY*

City Manager Wier addressed the Council reporting that this has previously come before the Council. He gave a brief history of the water system and enterprise funds. City Manager Wier went over the Prop 218 process and the pieces that need to be in place first. Samantha Ryan of RCAC gave an overview of the water rate study. She went over the Prop 218 overview and stated that the utility rates must be aligned with the cost of the service. She went over the proposed rates, which are based on meter size. City Attorney Rice went over the Prop 218 process and how to submit protests. Any water customer of record, or an owner record of a parcel receiving water service can submit a protest. The protest should have a statement indicating that the identified property owner or customer of record is in opposition to the proposed water rate changes, contains the address or APN, and a printed name and signature of the property owner or customer submitting the protest. Each eligible parcel gets one protest vote, if three are received for the parcel, only one is counted. Council Member Shamblin asked why we waited 10 years to have a rate increase. City Manager Wier stated the last rate increase was in 2017; and because COVID hit, it wasn't the right time to raise rates.

Linda Sutter: stated that the water fund had \$6mil and that is a surplus. Stated City staff is not being forthright on how much money is being received from water bills. Asked if the graph that shows Crescent City being the lowest in the area and if it was for water and sewer together.

Mark Bower: stated that people on fixed income are not going to be able to afford this. Spoke in support of raising the rates but needs to be a gradual increase.

Donna Westfall: spoke about the boarded-up businesses in the city, how few jobs there are in the community and raising rates will make our city continue to struggle. Asked for the City to find another way to generate revenue. Suggested selling treated wastewater as a source of revenue. Asked for the rates to be held off until the ad hoc committee is created to be an oversight to the WWTP. Asked if the protest succeeds what will the City do then.

Jody Mangum: stated that it appears that the Water Fund is steady. Asked what is being paid for and stated that it looks like more lines for the new development.

Sam Strait: with water, sewer, and electricity increases, it is a huge burden on the public.

Margaret Sargent: spoke about the upcoming fight against the rate increase. She spoke about behavioral health and domestic violence cases.

Mayor Wright asked for clarification that the water is chlorinated separate from the WWTP; City Manager Wier stated that yes, the drinking water does not pass through the WWTP.

Roy Thompson: spoke about a water main break on Maiden Lane. Feels whoever put the system in should be who pays for it.

Cate Classen: would like an audit to see where the money is coming from. Asked if the rate increase will pay for new hookups.

Council Member Greenough stated that there was a report for the annual audit a few Council meetings ago; City Manager Wier confirmed that they are done annually and was reported in a recent Council meeting. Council Member Greenough stated the audit is also on our website. The WWTP system is old and the State keeps changing the requirements on us. We still have to maintain the system so it's here for the future. At some point, inflation catches up with us and hard decisions need to be made. We have to maintain it to be responsible as it is our duty as stewards of the infrastructure. Mayor Pro Tem Tinkler stated that she agrees with Council Member Greenough. Things don't get better or cheaper in time. Passing the can down the road until it is more expensive is not a responsible thing to do to the community. A catastrophe will make for a much larger bill. Mayor Wright stated that the rate structure over the years is much more manageable. Council Member Greenough mentioned our Grant Writer who has done a great job bringing money into the community. Not everything can be covered by grants, but what can be covered by grants, we use them appropriately. City Manager Wier stated that a redundant well is being considered for grant funding and is not being considered with these rates. Looking at grants for these projects has been critical. The last major improvement project to the water system was back in 2000.

*On a motion by Mayor Pro Tem Tinkler, seconded by Council Member Greenough, and carried on a 4-1 polled vote, with Council Member Altman voting no, the City Council of the City of Crescent City waived full reading, read by title only and introduced Ordinance No. 862, AN ORDINANCE OF THE CITY COUNCIL OF THE CITY OF CRESCENT CITY AMENDING CHAPTER 13.16, WATER SERVICE RATES, OF TITLE 13, PUBLIC SERVICES, OF THE CRESCENT CITY MUNICIPAL CODE, approved and adopted Resolution No. 2026-25, A RESOLUTION OF THE CITY COUNCIL OF THE CITY OF CRESCENT CITY ADOPTING PROCEDURES FOR RECEIVING AND TABULATING PROTESTS AGAINST WATER RATE INCREASES UNDER PROPOSITION 218, and approved and adopted Resolution No. 2026-26, A RESOLUTION OF THE CITY COUNCIL OF THE CITY OF CRESCENT CITY AMENDING THE FY 2025-26 BUDGET OF THE CITY OF CRESCENT CITY.*

*Mayor Wright called a five minute recess at 8:38 pm. Meeting was reconvened at 8:45 p.m.*

## **9. Proposed Increases to Sewer Rates**

- *Recommendation: Hear staff report*
- *Technical questions from the Council*
- *Receive public comment*
- *Further Council discussion*
- *Waive full reading, read by title only and introduce Ordinance No. 863, AN ORDINANCE OF THE CITY COUNCIL OF THE CITY OF CRESCENT CITY AMENDING CHAPTER 13.30, SEWER CHARGES, OF TITLE 13, PUBLIC SERVICES, OF THE CRESCENT CITY MUNICIPAL CODE*
- *Approve and adopt Resolution No. 2026-27, A RESOLUTION OF THE CITY COUNCIL OF THE CITY OF CRESCENT CITY ADOPTING PROCEDURES FOR RECEIVING AND TABULATING PROTESTS AGAINST SEWER RATE INCREASES UNDER PROPOSITION 218*
- *Approve and adopt Resolution No. 2026-28, A RESOLUTION OF THE CITY COUNCIL OF THE CITY OF CRESCENT CITY AMENDING THE FY 2025-26 BUDGET OF THE CITY OF CRESCENT CITY*

City Manager Wier reported to the Council a brief history of the WWTP. He explained that the City rates are higher than the County rates because the County only has the treatment portion as the

cost of conveyance is put on their property tax bill. What is being discussed tonight is the operations and maintenance costs for the WWTP. The forgivable \$50mil loan has nothing to do with the rate increases. The proposed rates are only to address the costs of operations and maintenance. City Manager Wier stated that the narrative that these rate increases are done only for the developers is not the case. Chris Fisher, Vice President of Willdan Financial Services, addressed the Council and gave an overview of the Sewer Utility Rate Study. He stated that the last increase was over 10 years ago and inflation has raised the operational costs. City Attorney Rice went over the Prop 218 process as she had outlined in the water rate item. Mayor Pro Tem Tinkler responded to the comment that the Council needed to do their homework; she stated that one of the first items of business she had as a Council Member was to tour the WWTP. She further stated that the staff working at the WWTP are doing a tremendous job and deeply care about our community. Council Member Greenough stated that much like the water fund, the sewer fund is in the same boat. Something needs to be done about it. Council Member Shamblin stated that the rates could be reviewed in two-three years.

Linda Sutter: stated that the rate increase didn't have anything to do with the jobs being done by WWTP employees. Stated that the low-income apartment tenants don't pay for any water or sewer fees.

Donna Westfall: stated she was glad to hear that the \$50mil grant didn't have anything to do with the rate increase. Stated that in 2007 there was only one bid for the WWTP improvements. She spoke about former Public Works Director not putting the bid out to the area and was told by someone the bid was "fixed".

Sam Strait: stated that the focus on redundancy instead of fixing the problem is curious.

Mark Bower: asked why the City waited 10 years to raise the rates? Asked for a smaller steady increase instead of a huge increase right away.

Jody Mangum: stated that a portion of the bill is supposed to be towards maintenance.

Cate Classen: stated that in years past, a high rate vortex system was recommended to help with storm water surge. She asked about the City being out of compliance; being that we are in the tsunami zone, does the WWTP need to be moved. She spoke about all of the new apartments and the hotel going in at the casino. She asked, how we are going to handle all of the new hookups?

Margaret Sargent: spoke about the proposal that she submitted to the Council.

Council Member Greenough asked about multi-family housing and people using the vouchers from the Housing Authority, how does the funding work when it comes to sewer and water rates; do they pay? City Manager Wier stated that the vouchers help with rent. The water/sewer funds are separate – the complexes pay for the connections. He explained how the large complex pays for the water/sewer - they do pay for their equitable fair share for the water/sewer rates. Council Member Shamblin asked for clarification on the future hookups; City Manager Wier stated that the WWTP has received some fines because the regulations have changed. The current system cannot treat the influx of stormwater in compliance with the new permit regulations. He further stated that the WWTP has the capacity to receive all of the new hookups for all of the new proposed developments.

*On a motion by Mayor Pro Tem Tinkler, seconded by Council Member Shamblin, and carried on a 4-1 polled vote, with Council Member Altman voting no, the City Council of the City of Crescent City waived full reading, read by title only and introduced Ordinance No. 863, AN ORDINANCE OF THE CITY COUNCIL OF THE CITY OF CRESCENT CITY AMENDING*

*CHAPTER 13.30, SEWER CHARGES, OF TITLE 13, PUBLIC SERVICES, OF THE CRESCENT CITY MUNICIPAL CODE, approved and adopted Resolution No. 2026-27, A RESOLUTION OF THE CITY COUNCIL OF THE CITY OF CRESCENT CITY ADOPTING PROCEDURES FOR RECEIVING AND TABULATING PROTESTS AGAINST SEWER RATE INCREASES UNDER PROPOSITION 218, and approved and adopted Resolution No. 2026-28, A RESOLUTION OF THE CITY COUNCIL OF THE CITY OF CRESCENT CITY AMENDING THE FY 2025-26 BUDGET OF THE CITY OF CRESCENT CITY.*

### **CITY COUNCIL ITEMS**

- **Reports, Concerns, Referrals, Council travel and training reports – None**
- **Legislative Matters – None**
- **City Manager Report and City Council Directives –** City Manager Wier stated that Beachfront Park project is out to bid for the 13<sup>th</sup> of April. This project is funded by Prop 68.
  - Kamome Event – Director Feola outlined the upcoming Kamome Festival.

Mayor Wright asked if a letter of support for NCRCT can be on a future agenda; the Council was in consensus.

Council Member Shamblin asked for discussion about caps on short term rentals being on a future agenda; Council Member Greenough asked if researching that topic would take away from projects; City Manager Wier stated that it would take a significant amount of staff time to fully vet and implement.

### **ADJOURNMENT**

There being no further business to come before the Council, Mayor Wright adjourned the meeting at 9:54.m. to the regular meeting of the City Council of the City of Crescent City on Monday, April 20, 2026 at 6:00 p.m. at the Flynn Center Board Chambers, 981 H Street, Crescent City, CA 95531.

### **ATTEST**

---

Robin Altman  
City Clerk/Administrative Analyst

City of Crescent City  
 Biweekly Payroll Report  
 Payroll Ending 04/04/2026  
 Pay Date 04/10/2026

Check Numbers: 111799-111809 (Plus Direct Deposits)

Home Dept.	Regular Pay	Overtime	Gross Pay	Employees	Notes
City Council (110)	4,209.85	-	4,209.85	5	
Administration (111)	25,330.05	299.73	25,629.78	6	
Finance (120)	18,409.61	354.91	18,764.52	7	
City Attorney (130)	5,982.40	-	5,982.40	1	
Fire (230)	16,766.55	1,023.29	17,789.84	5	
Police (240)	53,280.69	4,964.65	58,245.34	16	
Planning (313)	814.80	-	814.80	1	
Public Works (350)	62,951.35	2,439.20	65,390.55	24	
Recreation (450)	5,604.80	-	5,604.80	2	
Swimming Pool (480)	27,486.99	-	27,486.99	24	Includes Final Payout
Housing (490)	12,247.10	-	12,247.10	4	
	233,084.19	9,081.78	242,165.97	95	
Payroll summarized above according to employees' home departments. Actual costs of employees are charged to department / fund where work was performed.					



## CITY COUNCIL AGENDA REPORT

**TO: MAYOR WRIGHT AND MEMBERS OF THE CITY COUNCIL**

**FROM: ERIC WIER, CITY MANAGER**

**BY: BRIDGET LACEY, GRANTS AND ECONOMIC DEVELOPMENT  
MANAGER**

**DATE: APRIL 20, 2026**

**SUBJECT: LETTER OF SUPPORT FOR BIGFOOT TRAIL NATIONAL RECREATION  
TRAIL DESIGNATION**

---

### **RECOMMENDATION**

- Approve a letter to Bigfoot Trail Alliance from the City Council endorsing the designation of the Bigfoot Trail as a National Recreation Trail

### **BACKGROUND**

The Bigfoot Trail Alliance has requested a letter of support from the City of Crescent City for its effort to designate the Bigfoot Trail as a National Recreation Trail under the National Trails System Act of 1968. The proposed 360-mile trail traverses northwest California and southwest Oregon, connecting a series of national forests, wilderness areas, and rural communities.

Crescent City serves as the northern terminus of the trail near Redwood National and State Parks, positioning the City as a key gateway for visitors accessing the route.

### **ITEM ANALYSIS**

The proposed National Recreation Trail designation is intended to recognize and promote trails that provide high-quality recreational opportunities while supporting conservation, public access, and community connectivity.

Approval of the attached letter of support would align the City with regional efforts to elevate the profile of the Bigfoot Trail and advance several local priorities:

- **Economic Development** - National recognition of the trail is anticipated to increase visitation to the region, supporting local businesses including lodging, dining, and retail. As a trail terminus, Crescent City is well-positioned to capture a share of this economic activity.

- **Tourism and Place Branding** - The designation would enhance Crescent City's visibility as an outdoor recreation destination, complementing existing assets such as coastal access, redwood forests, and proximity to state and national parks.
- **Regional Collaboration** - The Bigfoot Trail spans multiple jurisdictions and land management agencies. Supporting this effort reinforces the City's commitment to regional partnerships and coordinated approaches to recreation and conservation.
- **Recreation and Community Benefits** - The trail promotes outdoor recreation, environmental stewardship, and educational opportunities for residents and visitors. It also supports volunteerism and youth engagement in natural resource conservation.

Providing a letter of support for the Bigfoot Trail National Recreation Trail designation represents a low-cost opportunity for the City to support regional recreation, economic development, and conservation efforts.

### **FISCAL ANALYSIS**

There is no direct fiscal impact associated with approval of the letter of support. Participation is limited to a formal expression of support and does not obligate the City to any financial commitment at this time.

### **STRATEGIC PLAN ASSESSMENT**

This action is consistent with the following Strategic Plan Goals:

- Goal 1(E): Target economic development improvements that provide additional benefit by enhancing the quality of life for residents
- Goal 2(D): Collaborate with other jurisdictions and nonprofits to maximize regional effectiveness and amplify funding opportunities
- Goal 2(E): Create an environment that is conducive to attracting and retaining strong, sustainable businesses that reflect community needs and culture
- Goal 2(F)(9): Expand on the success of grant funding by maximizing utilization of opportunities with corresponding community needs

### **ATTACHMENTS**

1. Draft Letter of Support
2. Bigfoot Trail Map



**City of Crescent City**

*Where the Redwoods Meet the Sea*

377 J Street, Crescent City, CA 95531 • 707.464.7483 • Fax 707.465.4405 • [www.crescentcity.org](http://www.crescentcity.org)



April 20, 2026

Mary Kwart  
Bigfoot Trail Alliance  
P.O. Box 777  
Bayside, CA 95524

RE: Letter of Support for Bigfoot Trail National Recreation Trail Designation

Dear Ms. Kwart,

On behalf of the City Council of the City of Crescent City, I am pleased to offer our strong support for the designation of the Bigfoot Trail as a National Recreation Trail. Crescent City serves as the northern terminus of this remarkable 360-mile route, connecting visitors directly to the Pacific Ocean and the iconic landscapes of Redwood National and State Parks. The Bigfoot Trail represents an extraordinary opportunity to showcase the ecological richness of the region while strengthening connections between our rural communities and public lands.

Designation as a National Recreation Trail would bring meaningful benefits to Crescent City and similarly situated communities. Increased visitation associated with trail recognition has the potential to support local businesses, lodging, and services, contributing to sustainable economic development. At the same time, the trail promotes outdoor recreation, environmental education, and stewardship—values that align closely with our community’s priorities.

The Bigfoot Trail exemplifies a model of regional partnership that highlights biodiversity, cultural history, and access to public lands. We are particularly supportive of initiatives that engage volunteers, educate youth, and foster a deeper understanding of our unique natural environment.

The City of Crescent City supports efforts to ensure continued public access along the trail and appreciates the Bigfoot Trail Alliance’s leadership in coordinating this application. We look forward to continued collaboration and to the long-term benefits that National Recreation Trail designation would bring to our region. Thank you for your work in advancing this important initiative.

Sincerely,

Isaiah Wright, Mayor  
City of Crescent City

# BIGFOOT TRAIL

EXPLORE THE BIODIVERSITY OF THE KLAMATH MOUNTAINS

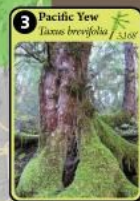
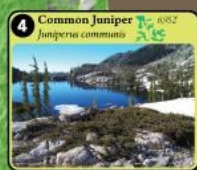
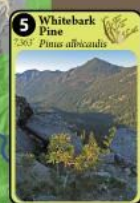
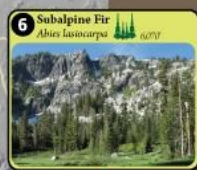
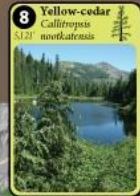
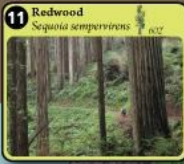
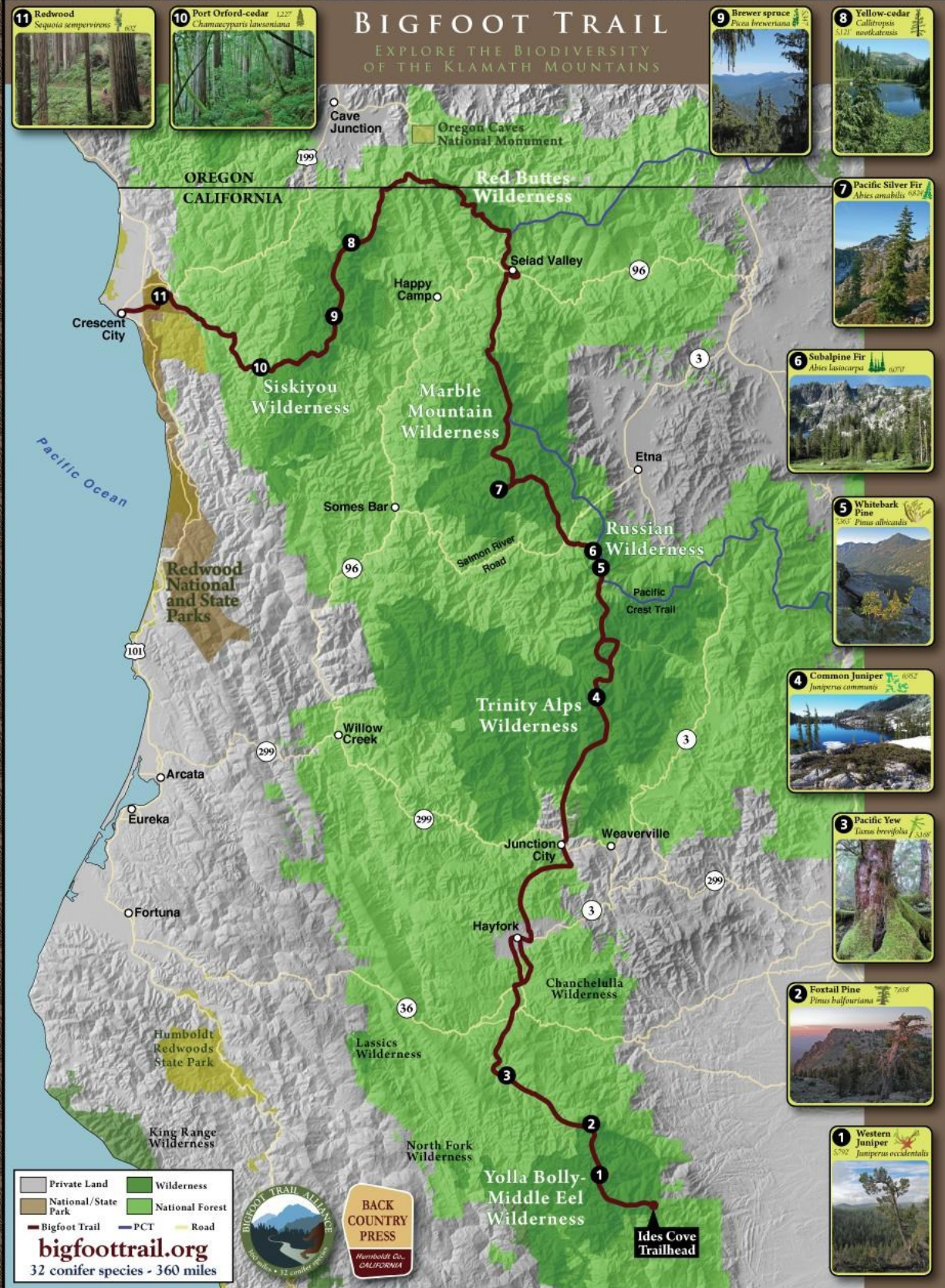

Private Land  
 Wilderness  
 National/State Park  
 National Forest  
 Bigfoot Trail  
 PCT  
 Road  
**bigfoottrail.org**  
 32 conifer species - 360 miles



# CITY COUNCIL AGENDA REPORT



**TO: MAYOR WRIGHT AND MEMBERS OF THE CITY COUNCIL**

**FROM: ERIC WIER, CITY MANAGER**

**DATE: APRIL 20, 2026**

**SUBJECT: LETTER REQUESTING STATE TO FUND VICTIM SERVICES**

---

## **RECOMMENDATION**

- Approve and authorize the Mayor to sign a letter requesting that the State fund victim services in the amount of \$100 million for next fiscal year

## **BACKGROUND**

At the April 6, 2026 Council meeting, Executive Director Amanda LeBlanc of the North Coast Rape Crisis Team asked the City Council to send a letter requesting the State to fund victim services in the upcoming fiscal year.

## **ITEM ANALYSIS**

Crime survivors across California rely on critical victim services every day, but without immediate state action, these programs face cuts of up to 40 percent. Victim programs are largely funded through the federal Victims of Crime Act (VOCA), and federal reductions have left a major funding gap. Nearly 1 million survivors depend on these services annually, including survivors of domestic violence, sexual assault, child abuse, elder abuse, human trafficking, and hate crimes.

Demand is rising, and cutting support now would undermine public safety, increase rates of survivor homelessness, increased mental health crises and leave vulnerable residents without help. Stable funding strengthens investigations, improves prosecution outcomes, and promotes safer communities.

## **STRATEGIC PLAN ASSESSMENT**

This action supports the following Strategic plan Goals:

- GOAL 1: SUPPORT QUALITY SERVICES, COMMUNITY SAFETY, AND HEALTH TO ENHANCE THE QUALITY OF LIFE AND EXPERIENCE OF OUR RESIDENTS AND VISITORS
  - A. Enhance collaboration with other agencies and the community to better aid the public.

## **ATTACHMENTS**

1. Draft Letter



**City of Crescent City**

*Where the Redwoods Meet the Sea*

377 J Street, Crescent City, CA 95531 • 707.464.7483 • Fax 707.465.4405 • [www.crescentcity.org](http://www.crescentcity.org)



April 20, 2026

Governor Gavin Newsom (via email)

Senator Mike McGuire (via email)

Assemblyman Chris Rogers (via email)

## FUNDING FOR VICTIM SUPPORT SERVICES

Dear Sirs:

Public safety is a shared priority for communities across California and ensuring that victims of crime have access to critical support services is an essential part of that commitment. I am writing on behalf of the City Council to respectfully urge you to include \$100 million in state funding in this year's budget to sustain these vital services for victims and survivors of crime.

In California, victim services are largely funded through the federal Victims of Crime Act (VOCA). Due to instability and significant reductions in federal allocations, these funds are no longer sufficient to maintain current service levels. Without state action, programs across our state are projected to face cuts of up to 40 percent. Nearly 1 million survivors rely on VOCA-funded services each year, including survivors of domestic violence, sexual assault, child abuse, elder abuse, and human trafficking.

Demand is not declining — it is intensifying. Domestic violence incidents are becoming more severe. Reports of elder abuse and child maltreatment continue to rise. Survivors of trafficking and hate crimes are seeking assistance in greater numbers. Reducing victim services at a time of increasing need would undermine public safety, strain law enforcement and emergency response systems, and leave vulnerable residents without essential support.

Sustaining these programs strengthens investigations, improves rates of survivors falling into homelessness, reduces repeat victimization, and promotes community stability. An investment of \$100 million in state funding is a critical step to ensure that victims receive the support they need and that our broader public safety system remains effective.

Thank you for your leadership and your commitment to safer communities. The City of Crescent City respectfully urges you to prioritize this funding in the state budget.

Sincerely,

Isaiah Wright, Mayor  
City of Crescent City



## CITY COUNCIL AGENDA REPORT

**TO: MAYOR WRIGHT AND MEMBERS OF THE CITY COUNCIL**

**FROM: ERIC WIER, CITY MANAGER**

**BY: MARTHA D. RICE, CITY ATTORNEY**

**DATE: APRIL 20, 2026**

**SUBJECT: ABANDONED VEHICLE ABATEMENT PROGRAM EXTENSION**

---

### **RECOMMENDATION**

- Approve and adopt Resolution No. 2026-29, A RESOLUTION OF THE CITY COUNCIL OF THE CITY OF CRESCENT CITY AUTHORIZING THE EXTENSION OF THE ABANDONED VEHICLE ABATEMENT PROGRAM UNTIL MAY 1, 2037

### **BACKGROUND**

In 1990, the California legislature enacted law allowing for the creation of county-based vehicle service authorities pursuant to the provisions of Section 22710 of the California Vehicle Code. In 1996, the Del Norte County Abandoned Vehicle Abatement Service Authority (“DN AVASA”) was formed as a joint powers authority including the County of Del Norte and the City of Crescent City. The Del Norte Solid Waste Management Board sits as the DN AVASA Board, which meets approximately quarterly. County staff perform vehicle abatement and related services.

The DN AVASA is funded by a one-dollar annual registration fee on vehicles registered to owners with an address in the County of Del Norte. Vehicle registration fees are collected by the Department of Motor Vehicles and allocated to the DN AVASA by the State Controller’s Office pursuant to Vehicle Code § 9250.7.

From January 1, 2016 to December 31, 2025, the DN AVASA received \$235,591.54, which has allowed staff to abate approximately 610 vehicles. See Tables A and B attached hereto.

### **ITEM ANALYSIS**

The current program is set to expire on May 31, 2027. The applicable state law allows the local service authorities to extend the programs every 10 years with the approval of the County and a majority of the incorporated areas. Adoption of the attached resolution is a necessary step towards the extension of this important program. A similar resolution

was recently adopted by the Del Norte County Board of Supervisors. A letter of intent to continue the program along with both entities' resolutions must be submitted to the California Department of Motor Vehicles by July 1, 2026.

### **FISCAL ANALYSIS**

This will not have an impact to the City's budget. However, the City will receive abandoned vehicle abatement services at no cost to the City.

### **STRATEGIC PLAN ASSESSMENT**

This action is consistent with the following Strategic Plan Goals:

- GOAL 1(A): Enhance collaboration with other agencies and the community to better aid the public.
- GOAL 1(C): Empower and utilize Police, Fire and Public Works departments to make Crescent City one of the safest cities in the United States.
- GOAL 2(A): Evaluate and optimize additional revenue sources.
- GOAL 2(B): Support community organizations that provide measurable services to the community.
- GOAL 2(D): Collaborate with other jurisdictions and non-profits to maximize regional effectiveness and amplify funding opportunities.

### **ATTACHMENTS**

1. Table A (AVA Revenue by Year) and Table B (AVA Tows by Fiscal Year)
2. Draft Resolution No. 2026-29

**Table A**  
**AVA Revenue by Calendar Year**

Year	Q3 (Jan–Mar)	Q4 (Apr–Jun)	Q1 (Jul–Sep)	Q2 (Oct–Dec)	Total
2016	\$5,989.15	\$6,928.14	\$6,126.49	\$5,339.50	\$24,383.28
2017	\$1,928.41	\$0.00	\$5,449.22	\$5,412.17	\$12,789.80
2018	\$6,319.55	\$6,378.54	\$5,960.28	\$5,470.85	\$24,129.22
2019	\$6,548.42	\$6,616.82	\$6,204.06	\$5,596.21	\$24,965.51
2020	\$6,259.84	\$6,099.98	\$6,641.91	\$5,841.01	\$24,842.74
2021	\$6,810.04	\$6,607.55	\$6,134.40	\$5,766.34	\$25,318.33
2022	\$6,543.39	\$6,485.45	\$6,477.75	\$5,453.88	\$24,960.47
2023	\$6,758.29	\$6,681.00	\$6,049.83	\$5,444.88	\$24,934.00
2024	\$6,611.10	\$6,542.75	\$6,186.23	\$5,424.02	\$24,764.10
2025	\$6,212.05	\$6,684.80	\$6,118.50	\$5,488.74	\$24,504.09

**Grand Total (2016–2025): \$235,591.54**

**Table B**  
**AVA Tows by Fiscal Period**

**January 1, 2016 – December 31, 2025**

Period	Number of Tows
Q3–Q4 2016	32
2016–2017	45
2017–2018	77
2018–2019	57
2019–2020	67
2020–2021	71
2021–2022	87
2022–2023	64
2023–2024	50
2024–2025	63
2025–2026*	29

**Total Tows: 610**

\*Partial period

**RESOLUTION NO. 2026-29**

**A RESOLUTION OF THE CITY COUNCIL CITY OF THE CITY OF CRESCENT CITY  
AUTHORIZING A TEN YEAR EXTENSION OF THE ABANDONED VEHICLE ABATEMENT  
PROGRAM UNTIL MAY 1, 2037**

**WHEREAS**, the Del Norte County Abandoned Vehicle Abatement Service Authority was formed in 1996; and

**WHEREAS**, the Del Norte County Abandoned Vehicle Abatement Program has contributed approximately \$24,000 annually for a ten-year total of \$235,591 countywide which has supported the participating agencies in the abatement of approximately 610 abandoned vehicles in Del Norte County;

**WHEREAS**, the Del Norte County Abandoned Vehicle Abatement Program is set to expire in 2027; and

**WHEREAS**, legislation allows for the extension of the program with the approval of the County and a majority of the cities comprising a majority of the population of the incorporated areas; and

**WHEREAS**, it is desirable to the City of Crescent City to have the program continue.

**NOW, THEREFORE, BE IT RESOLVED** by the City Council of the City of Crescent City that the extension of the Del Norte County Abandoned Vehicle Abatement Program until May 1, 2037 is hereby approved.

**PASSED and ADOPTED** and made effective the same day at a regular meeting by the City Council of the City of Crescent City held on the 20th day of April 2026, by the following polled vote.

AYES:  
NOES:  
ABSTAIN :  
ABSENT :

\_\_\_\_\_  
Isaiah Wright, Mayor

ATTEST:

\_\_\_\_\_  
Robin Altman, City Clerk



# CITY COUNCIL AGENDA REPORT

**TO: MAYOR WRIGHT AND MEMBERS OF THE CITY COUNCIL**

**FROM: ERIC WIER, CITY MANAGER**

**BY: DAVID YEAGER, PUBLIC WORKS DIRECTOR  
JAMES QUEEN, ENGINEERING PROJECT MANAGER**

**DATE: APRIL 20, 2026**

**SUBJECT: INCREASE TO MAINTENANCE BUDGET FOR THE WWTP FOR REPAIRS PERFORMED BY JACOBS**

---

## **RECOMMENDATION**

- Approve and adopt Resolution No. 2026-30, A RESOLUTION OF THE CITY COUNCIL OF THE CITY OF CRESCENT CITY AMENDING THE FISCAL YEAR 2025-26 BUDGET OF THE CITY OF CRESCENT CITY

## **BACKGROUND**

In 2019, the City signed a contract with Operations Management International, Inc. (also known as Jacobs Engineering) to perform operations, maintenance and management for the City's wastewater treatment plant. As a part of this contract with Jacobs, the City also provides Jacobs with an annual budget for making repairs to the plant. The yearly current budget for repairs is \$176,000. Any large purchases or repairs made to the plant must be approved by the City. At the end of each Fiscal Year Jacobs provides a detail cost breakdown on how the repairs budget was utilized. In establishing the budget for the next fiscal year City staff meets with Jacob's personnel to anticipate potential repairs/maintenance to the plant which are to be included in the annual repair budget. When repair costs for particular items are more than the \$176,000 annual budget can absorb, the City will include the purchase of the necessary materials/machinery and any contracting expenses in its annual budget for the WWTP so these repairs can occur as necessary.

## **ITEM ANALYSIS**

The membrane bioreactors, or MBRs, are vital components to the success of producing clean effluent so the City can comply with discharge permit requirements. As such, two spare MBR sludge pumps are kept on site in case a unit fails. One of the 15-year-old

pumps failed in December. At that time Jacobs began obtaining pricing for a single replacement. Before the replacement pump could be ordered, a second pump failed in February. As there were no longer any replacement pumps available as spares, Jacobs was authorized to purchase two pumps to fulfill the need to have two spare pumps on hand.

The total purchase price for the delivery of the two pumps was \$51,000. With three months left in the fiscal year, this \$51,000 purchase consumed the remaining annual Jacob's repair budget. Jacob's operations contract allows for the budget to be exceeded as long as authorized by the City. City staff requests a budget adjustment to cover this unanticipated additional \$51,412 expense.

### **FISCAL ANALYSIS**

The fiscal budget for FY 2025-2026 for WWTP maintenance is \$190,000. This covers the \$176,000 Jacobs budget as well as providing a contingency budget for unanticipated repair expenses. Staff will utilize this contingency budget but also need a budget adjustment of approximately \$40,000 to cover the balance of the \$51,412 MBR pump expense. This budget increase will allow Jacobs to continue their regular scheduled maintenance on the treatment plant.

### **STRATEGIC PLAN ASSESSMENT**

This report is consistent with the following Strategic Plan Goals:

- Goal 2: Support Quality Services, Community Safety, and Health to Enhance the Quality of Life and Experience of Our Residents and Visitors
  - D: Provide and maintain an efficient, adequate infrastructure to provide for both current and future community needs
- Goal 3: Obtain the Highest Levels of Organizational Excellence
  - B: Maintain responsible fiscal management and accountability

### **ATTACHMENTS**

1. Flo-Line Technology Inc. Quote for the 2 pumps
2. Draft Resolution No. 2026-30 (budget amendment)



**RESOLUTION NO. 2026-30**

**A RESOLUTION OF THE CITY COUNCIL OF THE CITY OF CRESCENT CITY AMENDING THE FISCAL YEAR 2025-26 BUDGET OF THE CITY OF CRESCENT CITY**

**WHEREAS**, the budget for the fiscal year beginning July 1, 2025 and ending June 30, 2026, as submitted by the City Manager, has been reviewed by the City Council and a duly-noticed public hearing held thereon the 16<sup>th</sup> day of June 2025; and

**WHEREAS**, the City Council adopted said budget by way of Resolution No. 2025-24 and has the authority to amend said budget from time to time; and

**WHEREAS**, the City owns and is responsible for maintenance of the Wastewater Treatment Plant (WWTP); and

**WHEREAS**, the City of Crescent City Wastewater Treatment Facility relies on the membrane bioreactors (MBRs) to comply with the NPDES discharge permit; and

**WHEREAS**, the WWTP needs two spare MBR pumps to replace the two recently failed pumps; and

**WHEREAS**, the City needs to increase the WWTP maintenance budget so regular maintenance performed by Jacobs can continue to occur; and

**WHEREAS**, the cost of these spare pumps was not foreseen nor budgeted; and

**WHEREAS**, fulfillment of these priorities requires an amendment to the City's Fiscal Year 2025-26 budget.

**NOW, THEREFORE, BE IT RESOLVED BY THE CITY COUNCIL OF THE CITY OF CRESCENT CITY AS FOLLOWS:**

1. That the Fiscal Year 2025-26 City of Crescent City Annual Budget is hereby amended and appropriated in the amounts identified below:

	Revenue Increase (Decrease)	Expenditure Increase (Decrease)
Sewer Fund		\$40,000

**APPROVED and ADOPTED** and made effective the same day at a meeting of the City Council of the City of Crescent City held on the 20<sup>th</sup> day of April 2026 by the following polled vote:

AYES:

NOES:

ABSTAIN:

ABSENT:

\_\_\_\_\_  
Isaiah Wright, Mayor

ATTEST:

\_\_\_\_\_  
Robin Altman, City Clerk



## CITY COUNCIL AGENDA REPORT

**TO: MAYOR WRIGHT AND MEMBERS OF THE CITY COUNCIL**

**FROM: ERIC WIER, CITY MANAGER**

**BY: BRIDGET LACEY, GRANTS AND ECONOMIC DEVELOPMENT  
MANAGER**

**DATE: APRIL 20, 2026**

**SUBJECT: DOWNTOWN FARMERS' MARKET LOCATION**

---

### **RECOMMENDATION**

- Hear staff report
- Technical questions from the Council
- Receive public comment
- Further Council discussion
- Approve and authorize the City Manager to sign the Agreement with the Del Norte and Tribal Lands Community Food Council for a Downtown Farmers' Market Location

### **BACKGROUND**

The Downtown Crescent City Farmers' Market, run by the Del Norte and Tribal Lands Community Food Council, is a community-driven marketplace that connects local farmers, food vendors, and craft vendors directly with residents and visitors. Operating as part of a broader effort to strengthen the regional food system, the market promotes access to fresh, locally grown produce while supporting small-scale agriculture and traditional food practices. The Downtown Crescent City Farmers' Market is a certified farmers' market which also accepts EBT. In addition to this the Food Council has brought Market Match funding to the Downtown Crescent City Farmers' Market, which increases the purchasing power of low-income shoppers at farmers' markets by providing a dollar-for-dollar match (or similar incentive) when customers use CalFresh (SNAP) benefits to buy fresh fruits and vegetables. This program is designed to improve access to healthy fresh food for low-income households, support local farmers and producers, strengthen regional food systems, and encourage healthier eating habits.

For many years the Farmers' Market was located in the library parking lot on Front and K Street, yet in 2024, the market was moved to the clock tower parking lot at the corner of 3<sup>rd</sup> and K Street, due to the construction on Front Street, and more recently was located at the former Bank of America parking lot at the corner of 2<sup>nd</sup> and H Street in 2025.

The three prior locations have been evaluated using the City's location intelligence and foot-traffic analytics platform and it has been determined that there was more foot-traffic at the 2<sup>nd</sup> and H Street location than the prior two locations (see attachment). While the 3<sup>rd</sup> Street location is still a consideration for future seasons, the Food Council has decided to return to the H Street location for the 2026 season. The thought is that with the planning efforts currently underway for downtown, there may be a future home for the Downtown Crescent City Farmers' Market in the Plaza (3<sup>rd</sup> and K Street) once that space has been adequately planned for and all potential street improvements in that area have been completed. This way, there is some stability to the current farmers' market location until then.

### **ITEM ANALYSIS**

The agreement before the City Council grants permission to the Food Council to utilize the parking lot at 240 H Street for the Downtown Farmers' Market for the 2026 market season (June through October). The agreement consists of the following key components:

- Electrical improvements: The City has installed several electrical outlets in the parking lot. Vendors and the Food Council may utilize these facilities for market purposes at no cost.
- Portable restrooms: The food Council will arrange for an ADA-accessible portable toilet and handwashing station to be present during the farmers' market for use by vendors and patrons. The City will pay 50% the cost of the portable restroom and handwashing station.
- Graywater: Graywater is untreated wastewater that has not come into contact with toilet waste, e.g. sinks, showers, laundry machines, dishwashers. Food trucks typically create graywater in their operation. Graywater cannot legally be disposed of into the storm drainage system. All vendors will be required to contain their graywater and dispose of it legally.
- Signage: Any signage that is proposed to remain on site, must be approved by the City prior to installation.
- Parking: Market vendors will be directed to park in the City parking lot located along Front Street between H and I Streets.
- Fee: The Food Council will pay a nominal fee of \$1.00 for use of the premises.

### **FISCAL ANALYSIS**

The additional cost of electricity is estimated to be approximately \$250. The cost of the portable toilet and handwashing station to the City is estimated to be \$1,300. Thus, pursuant to this Agreement, the City will incur approximately \$1,550 in direct costs. However, a successful farmers' market in the downtown corridor will create indirect benefits to the City by way of creating a positive effect on the local economy and providing local residents with access to healthy, locally sourced food products. All budgets have been accounted for in the FY27 budget which will go before Council in June 2026.

## **STRATEGIC PLAN ANALYSIS**

This item is consistent with the following strategic plan goals:

- Goal 1: Support Quality Services, Community Safety, and Health to Enhance the Quality of Life and Experience of Our Resident and Visitors
- Goal 2: Promote a Thriving Local Economy

## **ATTACHMENTS**

1. Agreement with Del Norte & Tribal Lands Community Food Council for a Downtown Farmers' Market Location
2. Farmers' Market Location Analysis Results

**AGREEMENT WITH DEL NORTE AND TRIBAL LANDS COMMUNITY FOOD COUNCIL  
FOR A DOWNTOWN FARMERS' MARKET LOCATION**

This agreement ("Agreement") is entered into by and between the City of Crescent City, a California municipal corporation ("City"), and the Del Norte & Tribal Lands Community Food Council, a California non-profit organization (the "Food Council"), for the purpose of facilitating a Downtown Farmers' Market in Crescent City.

**RECITALS**

- A. City is the owner of 240 H Street, Crescent City, California, consisting of a parking lot and commercial building. This is the former location of Bank of America.
- B. The Food Council successfully operated the 2025 Downtown Farmers' Market in the parking lot at 240 H Street.
- C. The City desires to continue to support the Food Council in creating a successful Downtown Farmers' Market as it will support the local economy by bringing shoppers into the downtown area, giving small business owners an affordable location to offer their products, and providing local residents with healthy food options.

**AGREEMENT**

**NOW, THEREFORE**, the parties do mutually agree to the following terms and conditions:

- 1. LICENSE. The City grants to the Food Council a temporary, revocable license to use the parking lot at 240 H Street, Crescent City (the "Premises") for the Downtown Farmers' Market on the terms identified in this Agreement.
  - 1.1 Term. The License granted hereunder is for the 2026 season (June through October).
  - 1.2 Days. The Food Council is authorized to occupy the Premises and conduct farmers' market activities every Wednesday and on other days as approved by the City Manager. The Wednesday market will be open from 9:00 am to 2:00 pm.
  - 1.3 Use. The Food Council is authorized to use the Premises for a farmers' market and for no other purpose.
  - 1.4 Fee. The Food Council shall pay the City a fee for the license granted herein of one dollar (\$1.00) for the 2026 season.
- 2. PERMITS. The Food Council is responsible for obtaining all permits necessary to operate a farmers' market on the Premises.
- 3. PORTABLE TOILETS. The Food Council will arrange for delivery and maintenance of an ADA-accessible portable toilet and handwashing station to be available to farmers' market patrons and vendors on days and times that the Downtown Farmers' Market is open. The City agrees to pay one-half the cost of the portable toilet / handwashing station.
- 4. GRAYWATER. Graywater may not be disposed of on the Premises. Graywater must be held in a storage tank and disposed of in accordance with California laws and regulations.
- 5. SIGNAGE. Any signage that is proposed to remain on the Premises during non-farmers' market days must be pre-approved by the City Manager. All signs must comply with the City's sign regulations contained in CCMC Chapter 17.39.

6. **PARKING.** The Food Council will direct vendors to park in the City parking lot along Front Street between H and I Streets during market hours so that street parking is available for market customers and business patrons.
7. **INSURANCE.** The Food Council, at its sole cost and expense, agrees to maintain during the term of this Agreement a policy of commercial general liability insurance with minimum limits of not less than \$1 million each occurrence and \$2 million aggregate. The insurance policy must be endorsed to: (i) include the City, its elected and appointed officials, employees, agents and volunteers as additional insureds; (ii) insure on an occurrence and not a claims-made basis; (iii) provide that the policy may not be cancelled without prior notice to City; and (iv) contain contractual liability coverage.
8. **INDEMNIFICATION.** The Food Council agrees to indemnify, defend, and hold harmless the City from any claim of damage to property or injury to person arising from its use of the Premises hereunder or a breach or default by the Food Council in the performance of any of its obligations or agreements hereunder, unless caused solely by the willful misconduct or gross negligence of the City. This paragraph will survive the expiration or earlier termination of this Agreement.
9. **NOTICES.** Any notice required or permitted to be given by either party upon the other must be in writing and given by hand delivery, certified mail, or overnight delivery service addressed as follows:

**If to City:**  
City of Crescent City  
Attn: City Manager  
377 J Street  
Crescent City, CA 95531

**If to DNATL CFC:**  
DNATL CFC  
Attn: Food System Program Director  
510 E. Washington Blvd.  
**Mailing Address:** 900 Northcrest Dr. #79  
Crescent City, CA 95531

Either party may change its address for delivery of notices by sending notice of such change as provided in this paragraph.

#### 10. GENERAL PROVISIONS.

- 10.1 **Compliance with Laws.** The Food Council agrees to comply with all applicable federal, state and local laws and regulations when performing activities in conjunction with this Agreement.
- 10.2 **Entire Agreement.** This instrument contains the entire agreement of the parties with respect to the subject matter contained herein. This Agreement supersedes any prior negotiations or representations, written or oral. No modification or amendment of this Agreement of any kind whatsoever may be made or claimed by either party and will have no force or effect whatsoever unless the same is evidenced by a writing signed by both parties.
- 10.3 **Severability.** In the event any term or provision of this Agreement is held to be illegal, invalid, unenforceable or inoperable as a matter of law, the remaining terms and provisions of this Agreement will not be affected thereby, but each such term and provision will remain valid and binding upon the parties.
- 10.4 **No Implied Waiver.** No delay or failure by either party to exercise any right under this Agreement, and no partial or single exercise of that right, may be interpreted to constitute a waiver of that or any other right hereunder.

- 10.5 No Assignment. The Food Council may not assign or otherwise transfer all or any part of its interest in this Agreement. Any attempt to do so is void and of no legal effect.
- 10.6 Governing Law / Venue. This Agreement is to be construed under and in accordance with the laws of the State of California. Any court action commenced to interpret or enforce this Agreement must be brought in the Superior Court of California in and for Del Norte County, or the United States District Court for the Northern District of California, as applicable.
- 10.7 Attorney's Fees. In the event that any legal proceeding is brought to interpret or enforce the terms of this Agreement, the prevailing party will be entitled to an award of reasonable attorney's fees and costs.
- 10.8 Electronic Signatures. Each Party of this Agreement agrees to the use of electronic signatures, such as digital signatures that meet the requirements of the California Uniform Electronic Transactions Act ("CUETA") Cal. Civ. Code §§ 1633.1 to 1633.17), for executing this Agreement. The parties further agree that the electronic signatures of the parties included in this Agreement are intended to authenticate this writing and to have the same force and effect as manual signatures. Electronic signature means an electronic sound, symbol, or process attached to or logically associated with an electronic record and executed or adopted by a person with the intent to sign the electronic record pursuant to the CUETA as amended from time to time. The CUETA authorizes use of an electronic signature for transactions and contracts among parties in California, including a government agency. Digital signature means an electronic identifier, created by computer, intended by the party using it to have the same force and effect as the use of a manual signature, and shall be reasonably relied upon by the Parties.

**IN WITNESS WHEREOF**, the parties hereto have caused this Agreement to be executed this 20<sup>th</sup> day of April 2026 at Crescent City, California.

**CITY OF CRESCENT CITY:**

**DNATL COMMUNITY FOOD COUNCIL:**

By: \_\_\_\_\_  
Eric Wier, City Manager



By:   
Iya Mahan, Food System Program Director

APPROVED AS TO FORM:

\_\_\_\_\_  
Martha D. Rice, City Attorney

## Civic Dashboard

Properties:

 <b>Farmer's Market 2023</b>	May 1 - Oct 31, 2023
1000 Front St, Crescent City, CA 95531	
 <b>Farmer's Market 2024</b>	May 1 - Oct 31, 2024
3rd Street, Crescent City, CA 75531	
 <b>Farmer's Market 2025</b>	May 1 - Oct 31, 2025
751 2nd Street, Crescent City, CA 95531	

Visitation data for and Farmer's Market 2024 is adjusted to exclude restricted locations.  
For additional info, please visit <https://www.placer.ai/company/privacy-faq>

### Applied Filters:

Time of Day: 8am - 3pm | Days: Wed



Scan to view on placer.ai platform



# Civic Dashboard

## Time Compare

Visitation data for and Farmer's Market 2024 is adjusted to exclude restricted locations. For additional info, please visit <https://www.placer.ai/company/privacy-faq>

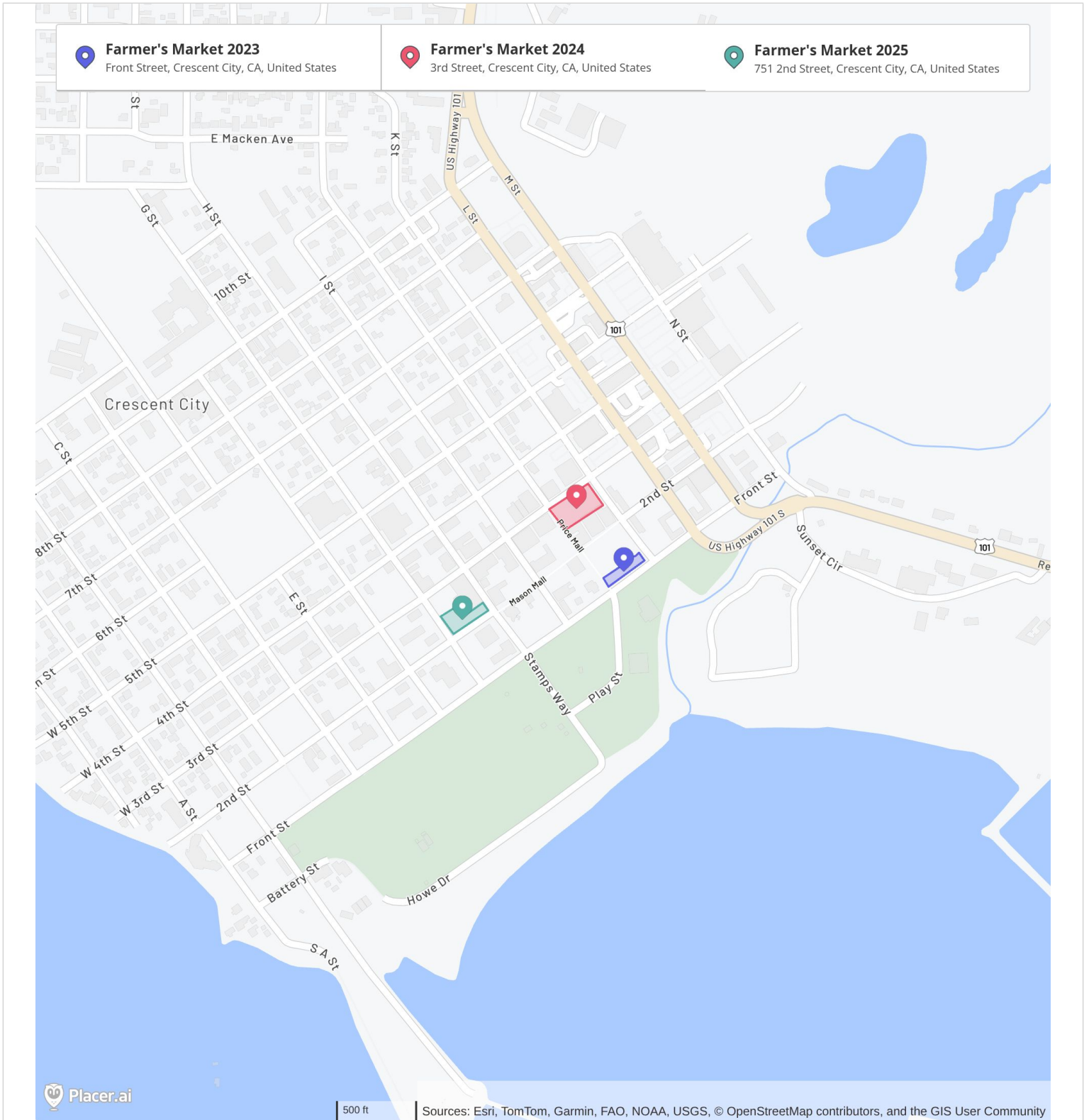



# Civic Dashboard

## Time Compare

Visitation data for and Farmer's Market 2024 is adjusted to exclude restricted locations. For additional info, please visit <https://www.placer.ai/company/privacy-faq>

### Visits Trend

- Farmer's Market 2023**  
Front St, Crescent City, CA
- Farmer's Market 2024**  
3rd Street, Crescent City, CA
- Farmer's Market 2025**  
2nd Street, Crescent City, CA

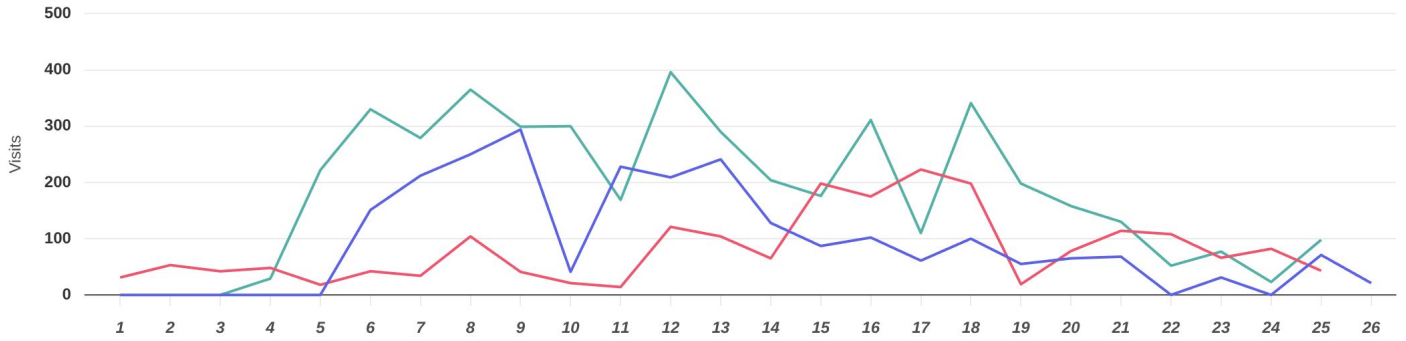

Weekly | Visits

Farmer's Market 2023 - May 1st, 2023 - Oct 31st, 2023

Farmer's Market 2024 - May 1st, 2024 - Oct 31st, 2024

Farmer's Market 2025 - May 1st, 2025 - Oct 31st, 2025

Data provided by Placer Labs Inc. ([www.placer.ai](http://www.placer.ai))



### Daily Visits

- Farmer's Market 2023**  
Front St, Crescent City, CA
- Farmer's Market 2024**  
3rd Street, Crescent City, CA
- Farmer's Market 2025**  
2nd Street, Crescent City, CA

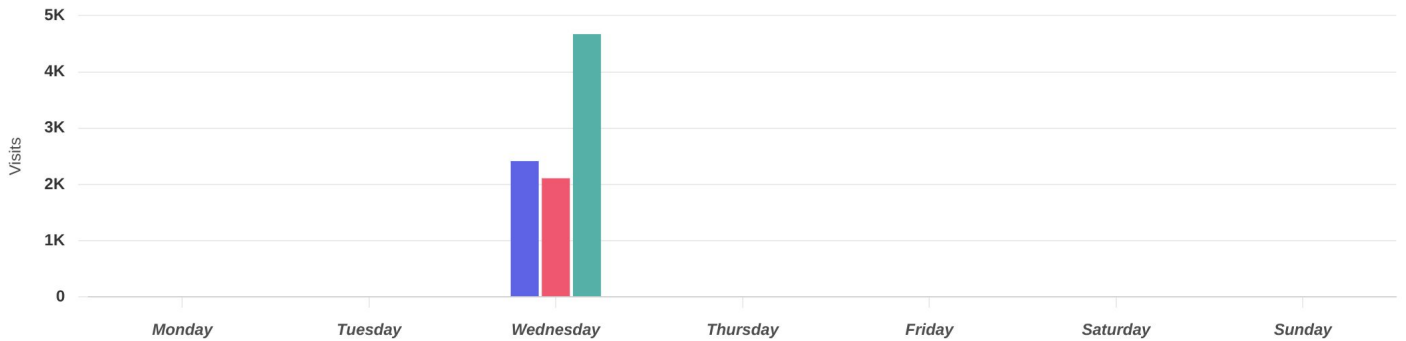

Visits

Farmer's Market 2023 - May 1st, 2023 - Oct 31st, 2023

Farmer's Market 2024 - May 1st, 2024 - Oct 31st, 2024

Farmer's Market 2025 - May 1st, 2025 - Oct 31st, 2025

Data provided by Placer Labs Inc. ([www.placer.ai](http://www.placer.ai))





# Civic Dashboard

## Time Compare

Visitation data for and Farmer's Market 2024 is adjusted to exclude restricted locations. For additional info, please visit <https://www.placer.ai/company/privacy-faq>

### Hourly Visits

**Farmer's Market 2023**  
Front St, Crescent City, CA

**Farmer's Market 2024**  
3rd Street, Crescent City, CA

**Farmer's Market 2025**  
2nd Street, Crescent City, CA

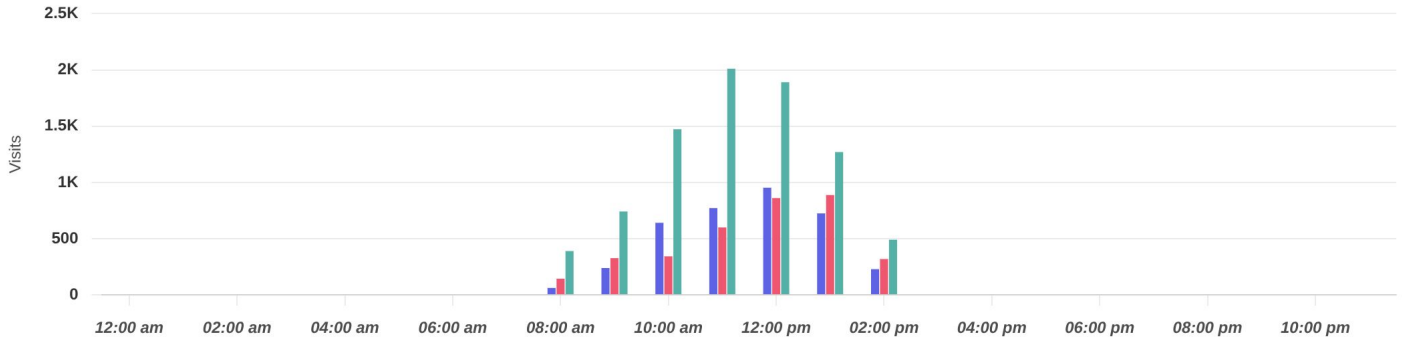

#### Visits

Farmer's Market 2023 - May 1st, 2023 - Oct 31st, 2023

Farmer's Market 2024 - May 1st, 2024 - Oct 31st, 2024

Farmer's Market 2025 - May 1st, 2025 - Oct 31st, 2025

Data provided by Placer Labs Inc. ([www.placer.ai](http://www.placer.ai))





# Civic Dashboard

## Time Compare

Visitation data for and Farmer's Market 2024 is adjusted to exclude restricted locations. For additional info, please visit <https://www.placer.ai/company/privacy-faq>

### Visitor Journey - Routes

#### Farmer's Market 2023

Front St, Crescent City, CA

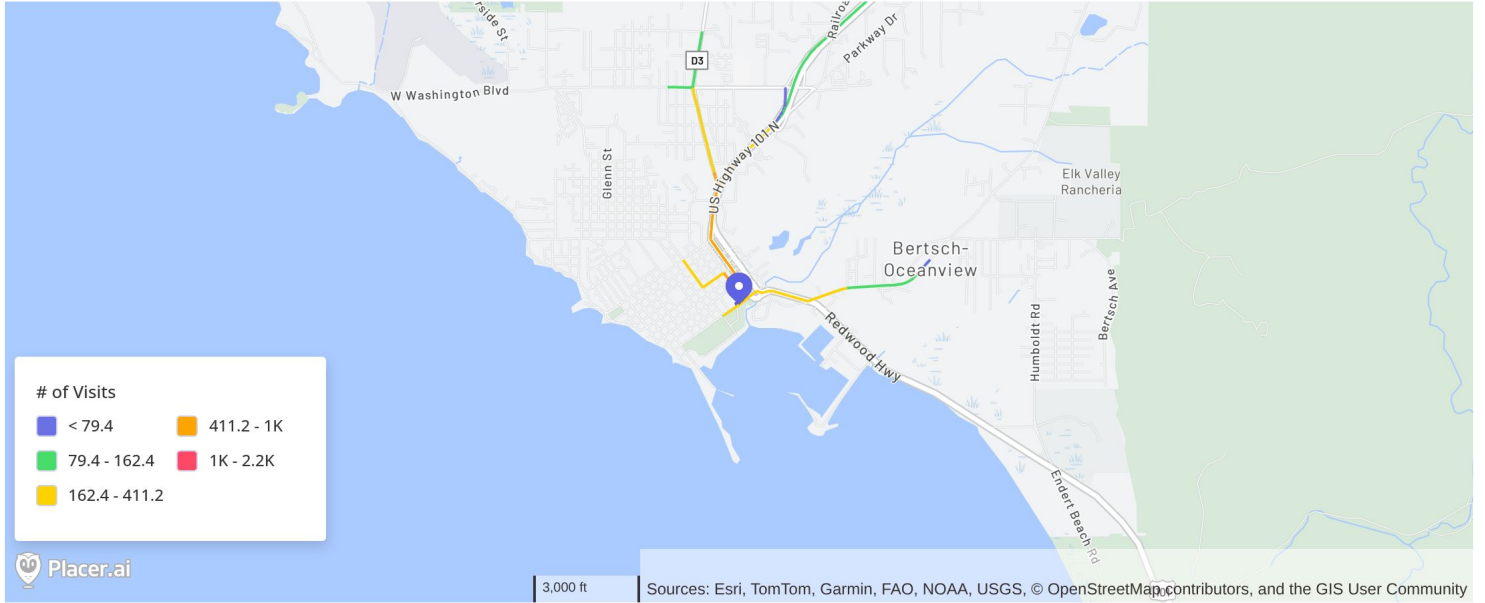

To protect individual privacy, the beginning points shown for each route are approximations and do not represent actual home locations.

Journey Direction: To Property | May 1st, 2023 - Oct 31st, 2023  
Data provided by Placer Labs Inc. ([www.placer.ai](http://www.placer.ai))





# Civic Dashboard

## Time Compare

Visitation data for and Farmer's Market 2024 is adjusted to exclude restricted locations. For additional info, please visit <https://www.placer.ai/company/privacy-faq>

### Visitor Journey - Routes

**Farmer's Market 2024**  
3rd Street, Crescent City, CA

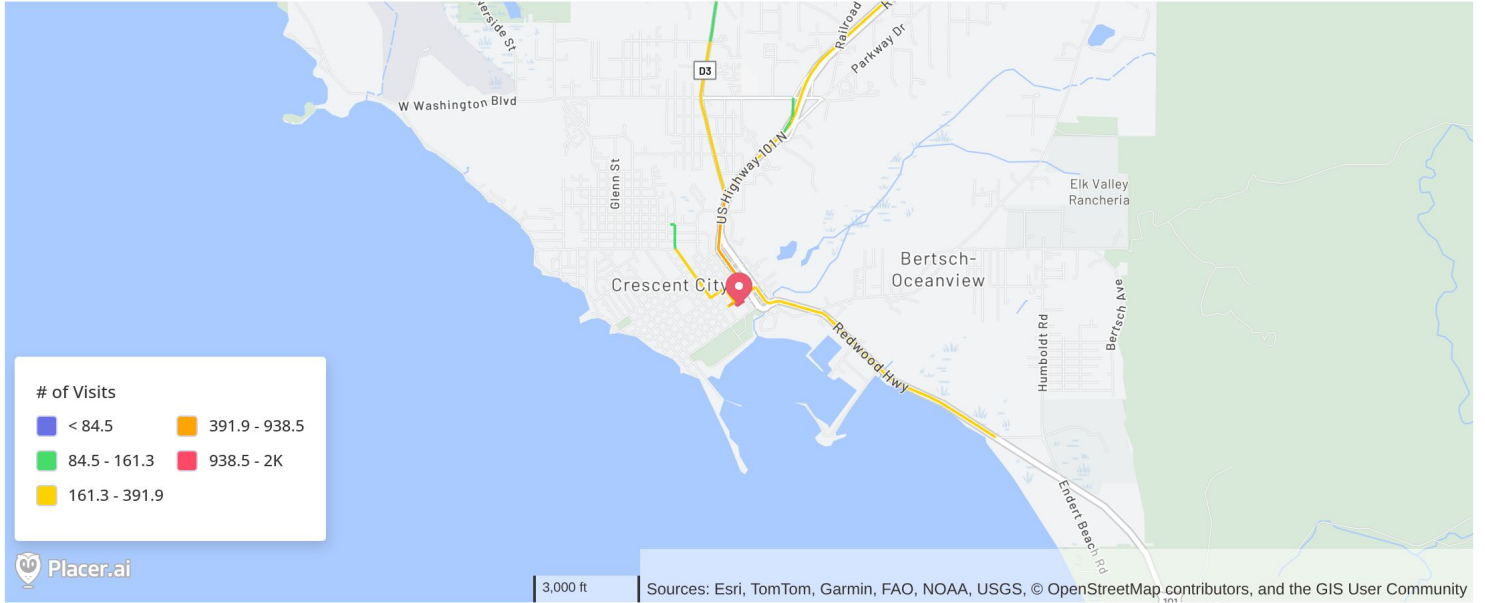

To protect individual privacy, the beginning points shown for each route are approximations and do not represent actual home locations.

Journey Direction: To Property | May 1st, 2024 - Oct 31st, 2024  
Data provided by Placer Labs Inc. ([www.placer.ai](http://www.placer.ai))





# Civic Dashboard

## Time Compare

Visitation data for and Farmer's Market 2024 is adjusted to exclude restricted locations. For additional info, please visit <https://www.placer.ai/company/privacy-faq>

### Visitor Journey - Routes

#### Farmer's Market 2025

2nd Street, Crescent City, CA

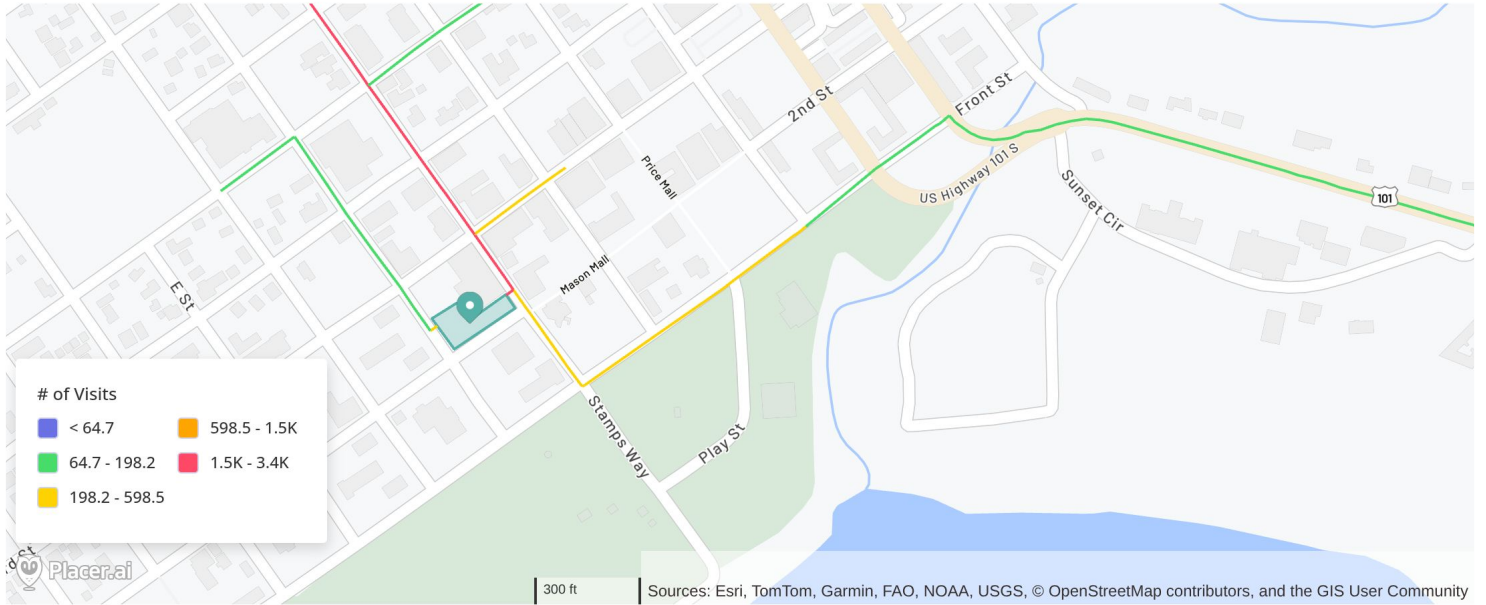

To protect individual privacy, the beginning points shown for each route are approximations and do not represent actual home locations.

Journey Direction: To Property | May 1st, 2025 - Oct 31st, 2025  
Data provided by Placer Labs Inc. ([www.placer.ai](http://www.placer.ai))





## CITY COUNCIL AGENDA REPORT

**TO: MAYOR WRIGHT AND MEMBERS OF THE CITY COUNCIL**

**FROM: ERIC WIER, CITY MANAGER**

**BY: BRIDGET LACEY, GRANTS AND ECONOMIC DEVELOPMENT  
MANAGER**

**DATE: APRIL 20, 2026**

**SUBJECT: LETTER OF SUPPORT FOR CITIZENS' DOCK PIER 2 CONSTRUCTION  
PROJECT**

---

### **RECOMMENDATION**

- Hear staff report
- Technical questions from Council
- Receive public comment
- Further Council discussion
- Approve a Letter to U.S. Department of Transportation Maritime Administration in support of the Citizens' Dock Pier 2 Construction Project.

### **BACKGROUND**

The Crescent City Harbor District (CCHD) is applying for \$11 million in funding through the U.S. Department of Transportation Maritime Administration's Port Infrastructure Development Program (PIDP) to construct a new Citizens' Dock Pier 2. This project represents the next phase of a comprehensive effort to replace aging harbor infrastructure and improve long-term operational capacity.

CCHD has previously secured \$15.3 million in funding for earlier phases of the project, including seawall replacement and construction of Citizens' Dock Pier 1, with construction anticipated to begin in 2026. The proposed Pier 2 project would complete the two-dock system and be constructed in the same location as the existing dock, maximizing use of the federal navigation channel.

The Harbor District has completed key predevelopment milestones, including design and engineering, environmental review under the National Environmental Policy Act (NEPA), and community engagement.

## **ITEM ANALYSIS**

The proposed Citizens' Dock Pier 2 project is a critical infrastructure investment with significant economic, operational, and resilience benefits. Approval of the letter of support would demonstrate the City's commitment to regional economic development and infrastructure modernization.

The harbor is a central component of the local economy, supporting commercial fishing, seafood processing, and marine-related businesses. Investment in modern dock infrastructure will enhance the Harbor's ability to support these industries, promote job creation, and strengthen regional economic competitiveness. Existing harbor infrastructure is experiencing increased service disruptions due to age and exposure to coastal storm events. Replacement of Citizens' Dock will improve safety, reliability, and operational efficiency for loading and unloading goods.

The project addresses known vulnerabilities to coastal hazards by replacing aging infrastructure with engineered, resilient facilities. This will improve the Harbor's ability to withstand future storm events and reduce the risk of service disruption.

Supporting this application aligns with the City's goals related to economic resilience, infrastructure investment, and support for working waterfronts and small business ecosystems.

## **FISCAL ANALYSIS**

There is no direct fiscal impact associated with approval of the letter of support. Participation is limited to a formal expression of support and does not obligate the City to any financial commitment at this time.

## **STRATEGIC PLAN ASSESSMENT**

This action is consistent with the following Strategic Plan Goals:

- Goal 1(E): Target economic development improvements that provide additional benefit by enhancing the quality of life for residents
- Goal 2(D): Collaborate with other jurisdictions and nonprofits to maximize regional effectiveness and amplify funding opportunities
- Goal 2(E): Create an environment that is conducive to attracting and retaining strong, sustainable businesses that reflect community needs and culture
- Goal 2(F)(9): Expand on the success of grant funding by maximizing utilization of opportunities with corresponding community needs

## **ATTACHMENTS**

1. Draft Letter of Support



**City of Crescent City**

*Where the Redwoods Meet the Sea*

377 J Street, Crescent City, CA 95531 • 707.464.7483 • Fax 707.465.4405 • [www.crescentcity.org](http://www.crescentcity.org)



April 20, 2026

U.S. Department of Transportation  
Maritime Administration

1200 New Jersey Avenue, SE  
Washington, DC 20590

To the Honorable Stephen M. Carmel, MARAD Administrator:

On behalf of the City Council of the City of Crescent City, I am pleased to express our strong support for the Crescent City Harbor District's application for funding through the U.S. Department of Transportation Maritime Administration to construct a new Citizens' Dock Pier 2.

The proposed project represents a critical investment in the long-term functionality, safety, and resilience of our harbor—an essential economic engine for Crescent City and the surrounding region. Replacing the aging Citizens' Dock with modern infrastructure will ensure continued access for commercial, recreational, and emergency maritime activities while maximizing the use of the federally maintained navigation channel.

We commend the Harbor District for its efforts to improve safety, operational efficiency, and resilience in the face of coastal hazards by modernizing this failing dock infrastructure. This investment will support economic development by strengthening the harbor's capacity to serve commercial fishing, marine services, and visiting vessels, while also enhancing public access and waterfront vitality.

The Crescent City Harbor is a cornerstone of our community's identity and economy. Continued federal partnership is essential to ensuring that this vital asset remains functional and competitive for decades to come.

For these reasons, the City Council of the City of Crescent City strongly supports the Harbor District's application and respectfully urges favorable consideration of this request.

Sincerely,

Isaiah Wright, Mayor  
City of Crescent City



## CITY COUNCIL AGENDA REPORT

**TO: MAYOR WRIGHT AND MEMBERS OF THE CITY COUNCIL**  
**FROM: ERIC WIER, CITY MANAGER**

**BY: DAVID YEAGER, DIRECTOR OF PUBLIC WORKS**  
**CLIFF VAN HOOK, ENGINEERING PROJECT MANAGER**

**DATE: APRIL 20, 2026**

**SUBJECT: LIGHTHOUSE COVE APARTMENT REMODEL BUDGET ADJUSTMENT**

---

### **RECOMMENDATION**

- Hear staff report
- Technical questions from Council
- Receive public comment
- Further Council discussion
- Approve and adopt Resolution No. 2026-31, A RESOLUTION OF THE CITY COUNCIL OF THE CITY OF CRESCENT CITY AMENDING THE FISCAL YEAR 2025-26 BUDGET OF THE CITY OF CRESCENT CITY
- Direct staff to publish a notice inviting bids for this project.

### **BACKGROUND**

In 1963 the City of Crescent City received a State Land Grant and became the owner of certain tidelands and submerged lands including the land where Lighthouse Cove RV Park now sits. The RV Park was originally constructed in 1971 and the City leased the land to a third party for many years. In 2006, the City took over the management of what was then “Shoreline RV Park” and began to directly oversee its operations.

After receiving an Economic Development Administration grant, the City embarked on a major remodel for the park in 2015 that included a reduction of the total sites from 192 to 94 and focused on customer experience including the layout of sites, upgrades to utilities, and improved amenities.

During the FY 23-24 budget workshop for the City Council, the Lighthouse Cove RV Park enterprise fund was discussed, and it was brought to the Council’s attention that revenues were not projected to cover future expenses. Increasing revenues was discussed including raising the space rent fees and possibly renting the apartment located above the park’s office and restrooms.

Staff research showed the RV Park’s rates were below the market averages, but concerns were voiced regarding raising the rates with our facilities being in substandard condition. The revenue streams could not afford to improve the bathrooms as well as upgrade the roads. The 1,200 square foot apartment would be rentable with some updating, but since it wasn’t ADA compliant, it couldn’t be rented out without an alternate ADA accessible rental available.

With a need to increase the overall revenues to improve the guest experience and maintain the park and make capital improvements, the goals became: (1) to update the park’s restrooms, (2)

## Lighthouse Cove RV Park Apartment Remodel Budget Adjustment

April 20, 2026

provide an ADA accessible short term rental space, and (3) update the upstairs apartment. After establishing these three goals, City staff applied for and received a grant through the State Coastal Conservancy for \$835,000. This grant came without a required City match, but there is working capital within the RV Park budget for contingency if required to meet grant deliverables. This grant was accepted by City Council through Resolution No. 2024-102 on December 16, 2024. This grant funding will be utilized to achieve the three desired grant deliverables:

- Lighthouse Cove Bathroom Remodel, to improve the guest experience for all patrons of the RV Park.
- Install 2 prefabricated ADA compliant cabins along Elk Creek for use as short-term rentals, providing accessible lower-cost accommodations.
- Remodel the upstairs Lighthouse Cove Apartment so it can be used for short-term rentals.

The Coastal Conservancy grant objective of providing lower cost accommodations adjacent to the beach will benefit the visiting public allowing them to stay in our coastal community. The project listed above will provide (2) ADA and (1) non-ADA lower-cost short-term rental options. This will increase the Park's overall revenue to ensure a more viable business model, allowing the city to continue making capital improvements such as improving the road within the park.

### **ITEM ANALYSIS**

The original plan for the apartment remodel was to limit the demolition and perform structural small-scale improvements such as removing the popcorn ceiling, installing new lights and ceiling fans, replacing the stairs, levelling the floors, and remodeling the 1970s kitchen and bathroom. An asbestos abatement contractor, along with City's public works crews, have begun demolition and have leveled the floors. Upon performing this work, additional items requiring improvement have been exposed and deemed necessary to complete the project.

The anticipated work on the apartment is \$363,100, of which \$95,000 is included in the original budget of the received Coastal Conservancy grant. Cost underruns on design/permitting and the cabin construction is providing additional grant funding to be allocated to the apartment improvements. Staff is requesting an additional \$200,000 from the Lighthouse Cove RV Park enterprise fund to complete the expanded scope of capital improvements for the apartment.

The expanded scope will include the following items deemed necessary to provide a safe rental apartment for the public:

- Fire escape requirements: Two forms of egress are required by the building code. Currently there is only one interior staircase providing egress, and it is situated adjacent to the building's water heaters. Due to the extended roof soffit the provided rope ladder was determined not to be a realistic safe exit. In discussions with the Fire Chief, an exterior exit could utilize a fixed ladder. This ladder will be accessed from a 2<sup>nd</sup> story deck. This deck, rail, and ladder will need to be constructed. Along with the installation of a new door for access, this deck facing the ocean will increase the amenities of the unit as a short-term rental.
- The electrical wiring appears to have been modified in prior renovations. Staff plan to have a full inspection performed of the existing wiring by a licensed electrician. The drywall will be removed as necessary for this evaluation. This will also allow the city to obtain electrical drawings including load calculations. An upgrade of the sub panel currently feeding the apartment is included in this expanded scope.

Lighthouse Cove RV Park Apartment Remodel Budget Adjustment  
April 20, 2026

- Heating and cooling upgrades. The original budget included upgrades to the wall heater units. In discussions with local contractors, the apartments environment will be more effectively controlled with the addition of a mini split for heating and cooling.
- Insulation replacement: Insulation replacement is required in the attic and some walls. Prior water damage has reduced the effectiveness of the existing insulation.
- Asbestos was found in the gypsum board and joint compound. With the need for additional demolition due to the increased scope of work, a full asbestos abatement will be performed for the benefit of the current and future projects.

With council approval a notice inviting bids for the apartment project will be released, with the lowest responsible bidder being awarded a contract, as long as the bid is within the provided budget.

**FISCAL ANALYSIS**

The original grant budget is shown in the chart below.

Design and Permitting	\$32,500
Construction – Cabins	\$449,200
Construction – Restrooms	\$258,600
Construction – Apartment	\$94,700
<b>Total</b>	<b>\$835,000</b>

If the City is to proceed with the full abatement and rebuild of the apartment, City staff anticipate a budget of roughly \$370,000 will be required. Since the original budget, pricing on most of the other planned components have been quantified, the updated projected budget is shown in the chart below. Please note, the “Design and Permitting” line item has been spread across the 3 projects in the below.

Construction – Cabins (including design and permitting)	\$405,700
Construction – Restrooms (including design and permitting)	\$258,600
Construction - Apartment full abatement and rebuild (including design and permitting)	\$363,100
<b>Total cost for grant deliverables and expanded scope of improvements</b>	<b>\$1,027,400</b>
<b>Less grant funding</b>	<b>(\$835,000)</b>
<b>RV Park cash reserves required</b>	<b>\$192,400</b>
<b>RV Park cash reserves requested</b>	<b>\$200,000</b>

Lighthouse Cove RV Park Apartment Remodel Budget Adjustment  
April 20, 2026

To help determine if this increase in scope to the apartment project is fiscally responsible, staff performed a cost/benefit analysis to determine the time period required to replenish the reserves expended for these additional apartment improvements.

City Proposed Rental Rate for Apartment Per Night	\$200 - Summer (May – September) \$150 – Off Season (Oct – April)
Estimated Annual Nights Rented	110 Nights (Summer) 90 Nights (Winter)
Estimated Annual Net Revenue	\$30,000 / Year
RV Park Funds Used On Apartment buildout	\$200,000
Payback Period (ROI)	6.7 Years to Payback City Funds Used

Staff recommend increasing the overall project by \$200,000. The RV Park Fund had a working capital balance of \$680,123 as of the most recent audit (6/30/25), and the current fiscal year budget (as of the mid-year budget update) reflects a working capital balance of \$648,516 at the end of this year. The payback period for the apartment revenue to replenish the RV Park working capital balance used for this project is conservatively estimated to be less than 7 years.

The increased rents received for the rental of the cabins covered under the grant will provide immediate increased revenue. After the apartment payback to the RV fund is completed, another long-term revenue stream will have been added. These three additional revenue streams, conservatively estimated to net over \$60,000 annually, can be utilized to make further improvements to the park, such as communication, road and drainage improvements.

**STRATEGIC PLAN ASSESSMENT**

This action supports the following Strategic Plan Goals:

GOAL 1: SUPPORT QUALITY SERVICES, COMMUNITY SAFETY, AND HEALTH TO ENHANCE THE QUALITY OF LIFE AND EXPERIENCE OF OUR RESIDENTS AND VISITORS

D. Provide and maintain an efficient, adequate infrastructure to provide for both current and future community needs

GOAL 2: PROMOTE A THRIVING LOCAL ECONOMY

C. Research and implement methods to increase local tourism and funding for tourism promotion

F. Plan and prepare for the growth and future needs of the Crescent City community by:

- Engaging with residents, visitors, and businesses through ongoing marketing of City products, services, and facilities
- Expanding on the success of grant funding by maximizing utilization of opportunities with corresponding community needs

**ATTACHMENTS**

1. Exhibit 1: Lighthouse Cove Apartment Remodel – Full abatement
2. Draft Resolution No. 2026-31 (budget amendment)

# Lighthouse Cove RV Park - Apartment Remodel

Drawing Index
Demo Plan - Level 1
Demo Plan - Level 2
Framing Plan - Level 2
Floorplan - Level 1
Floorplan - Level 2
Electrical Plan - Level 1
Electrical Plan - Level 2
Electrical Plan - Level 2 RCP
Plumbing Plan - Level 2
HVAC Plan - Level 1
HVAC Plan - Level 2
FFE
Exterior Deck Plan 1
Exterior Deck Plan 2



Drawings are not to scale, all takeoffs and measurements to be field verified.

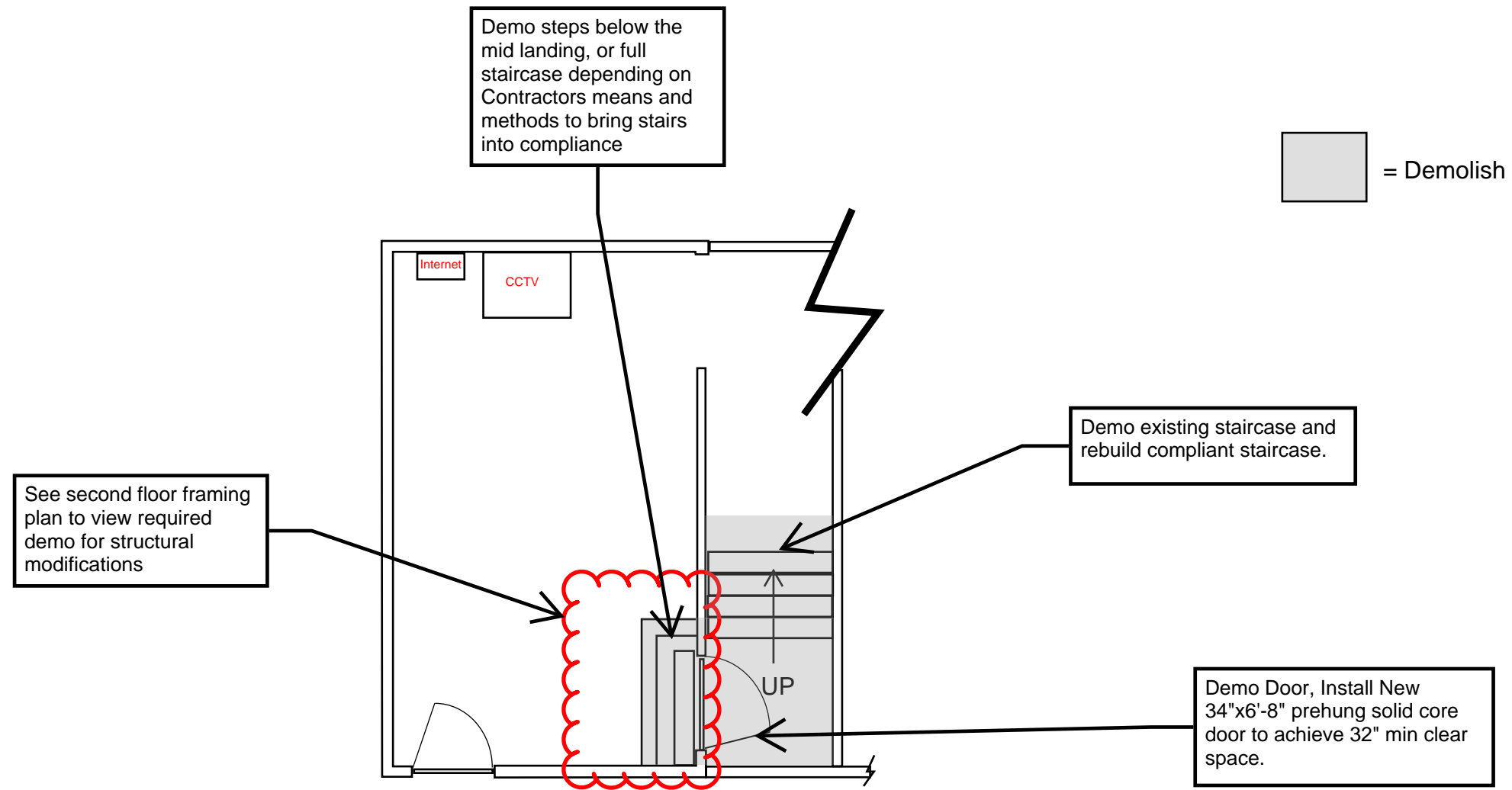

Demo steps below the mid landing, or full staircase depending on Contractors means and methods to bring stairs into compliance

 = Demolish

Demo existing staircase and rebuild compliant staircase.

See second floor framing plan to view required demo for structural modifications

Demo Door, Install New 34"x6'-8" prehung solid core door to achieve 32" min clear space.

First Floor - Demo Plan

1. Gypsum board removal Not In Contract. Owner to hire abatement contractor to demo all finishes down to the sub floor, wall studs, and ceiling joists, except the gyp board directly behind the kitchen cabinetry. Kitchen cabinetry will remain in place.
2. Electrician to inspect wiring, demo as required to ensure wiring is up to code.
3. Demo exterior soffit and patch as required to run line sets from condenser to head unit on the mini split.
4. Existing kitchen countertop has been demo'd.

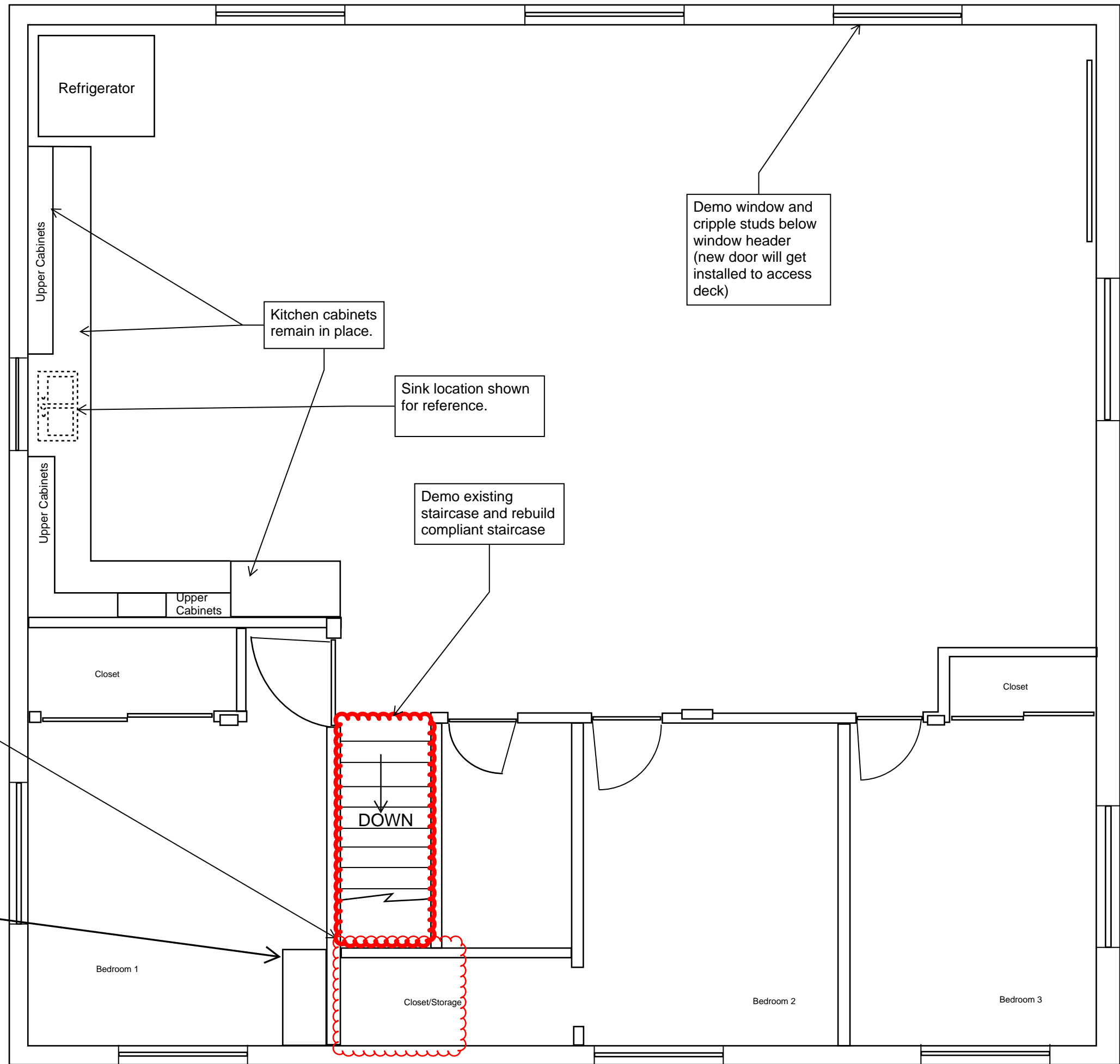

Second Floor - Demolition

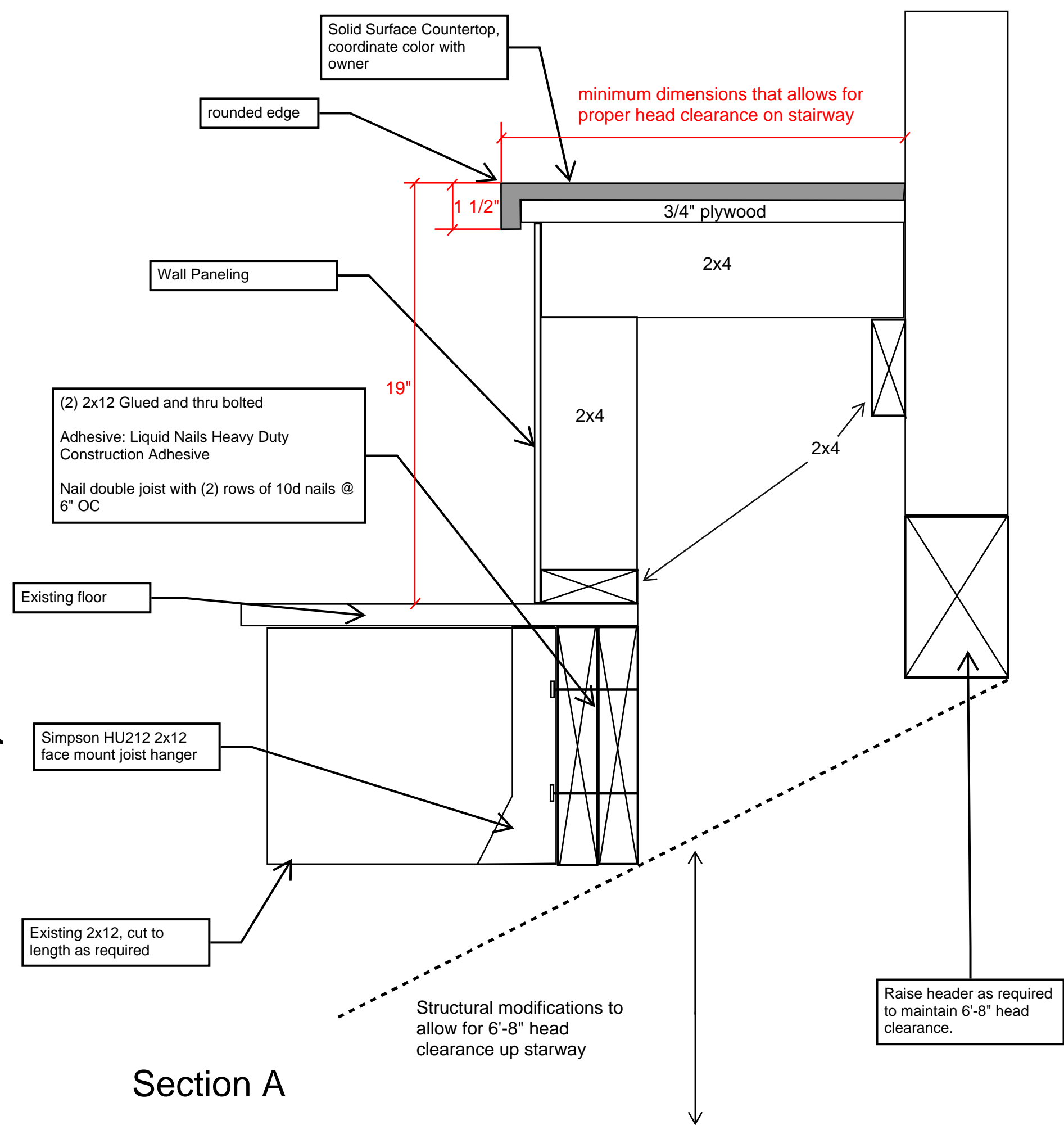
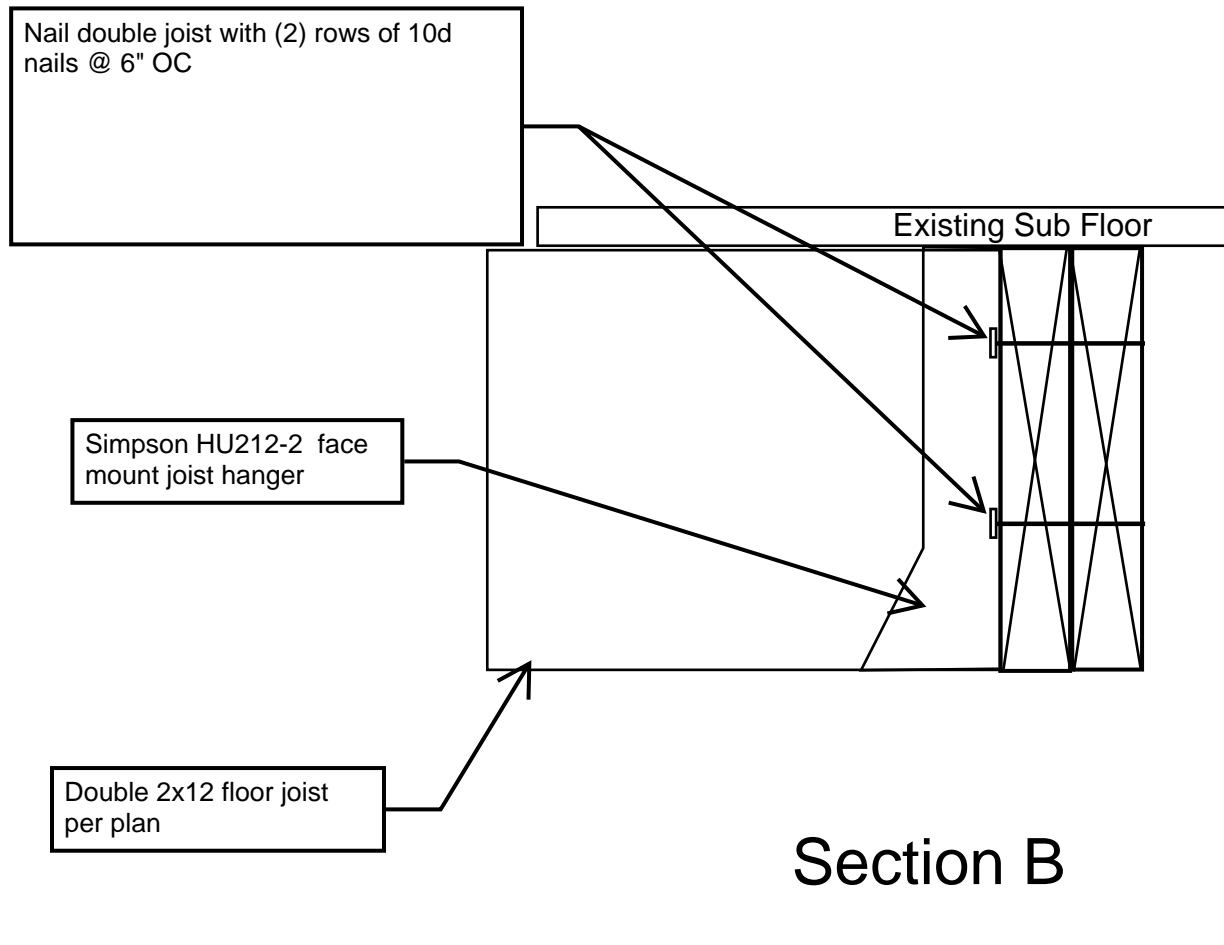

1. Coordinate required head clearance at the stairs with the structural modifications. Confirm built up bench dimensions with owner prior to altering structure.
2. Underside of structure must be drywalled.

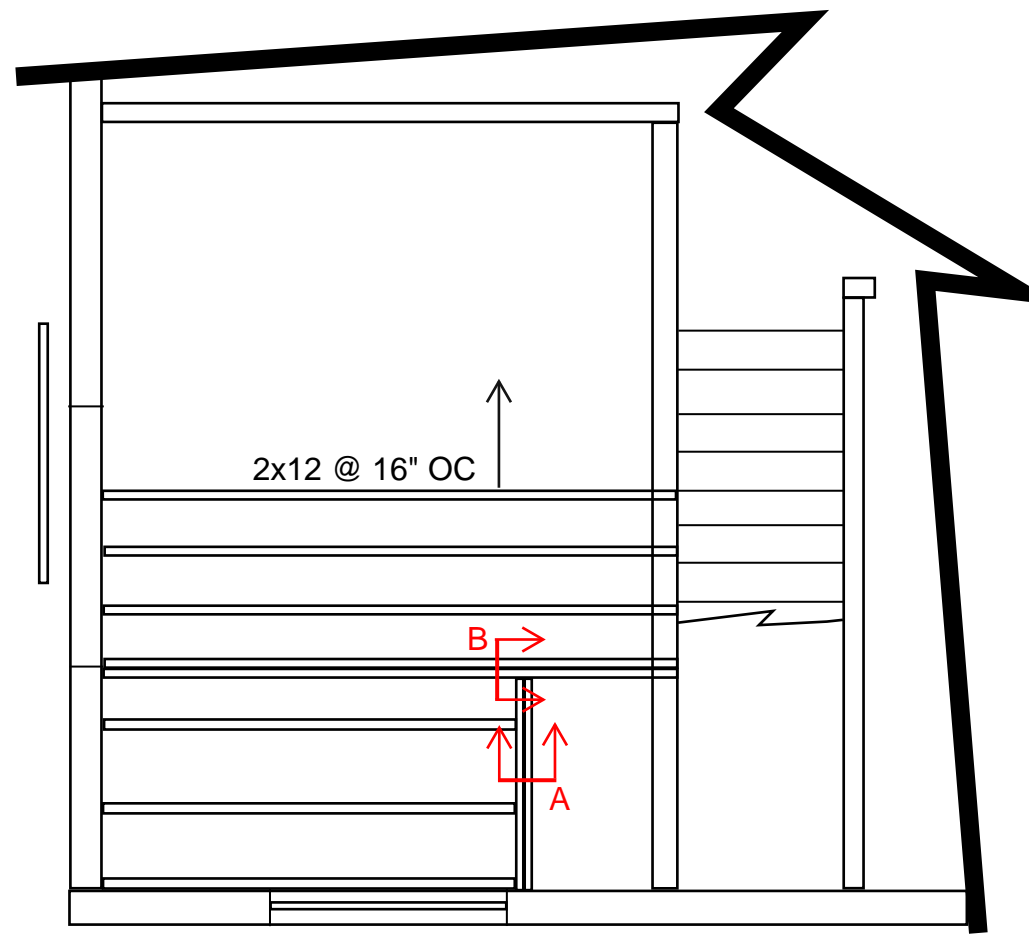

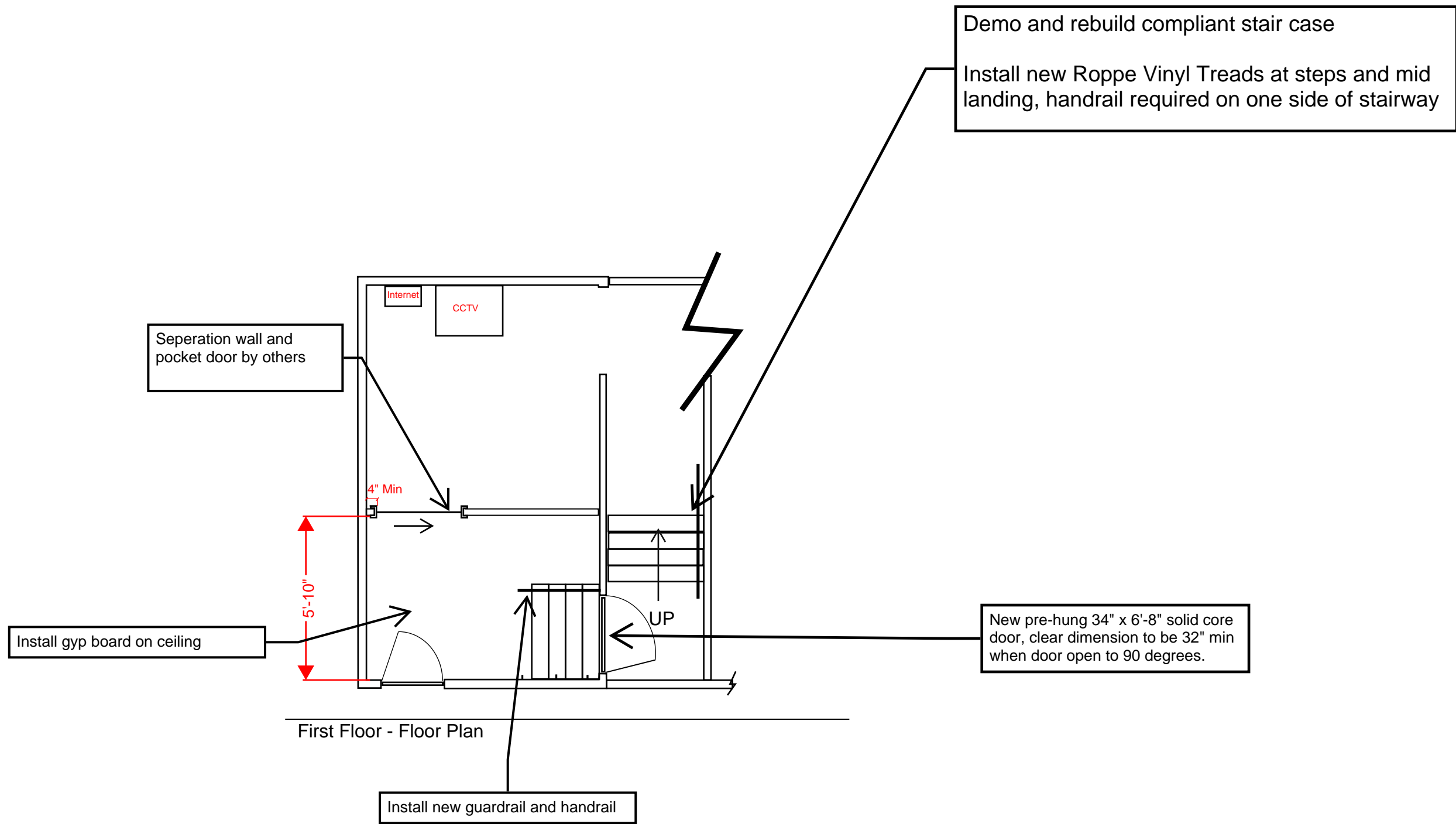

1. All kitchen cabinetry imperfections to be filled with wood putty, sanded, and painted, typ. Remove existing hardware and replace with new hardware, typical.
2. Drywall to be level 4 finish with light texture.
3. Some of the subfloor will require feathering or self leveler. Coordinate final plan with owner representative.
4. Install new insulation throughout. R-15 at exterior walls, R-13 at interior walls, and R-30 at 2x12 roof joists.
5. Install square MDF baseboard and casings throughout, typical. No crown moulding required.
6. See finish schedule for materials specifications.

 = 1"x6" T&G knotty pine, with chalk paint finish. Coordinate color with owner.

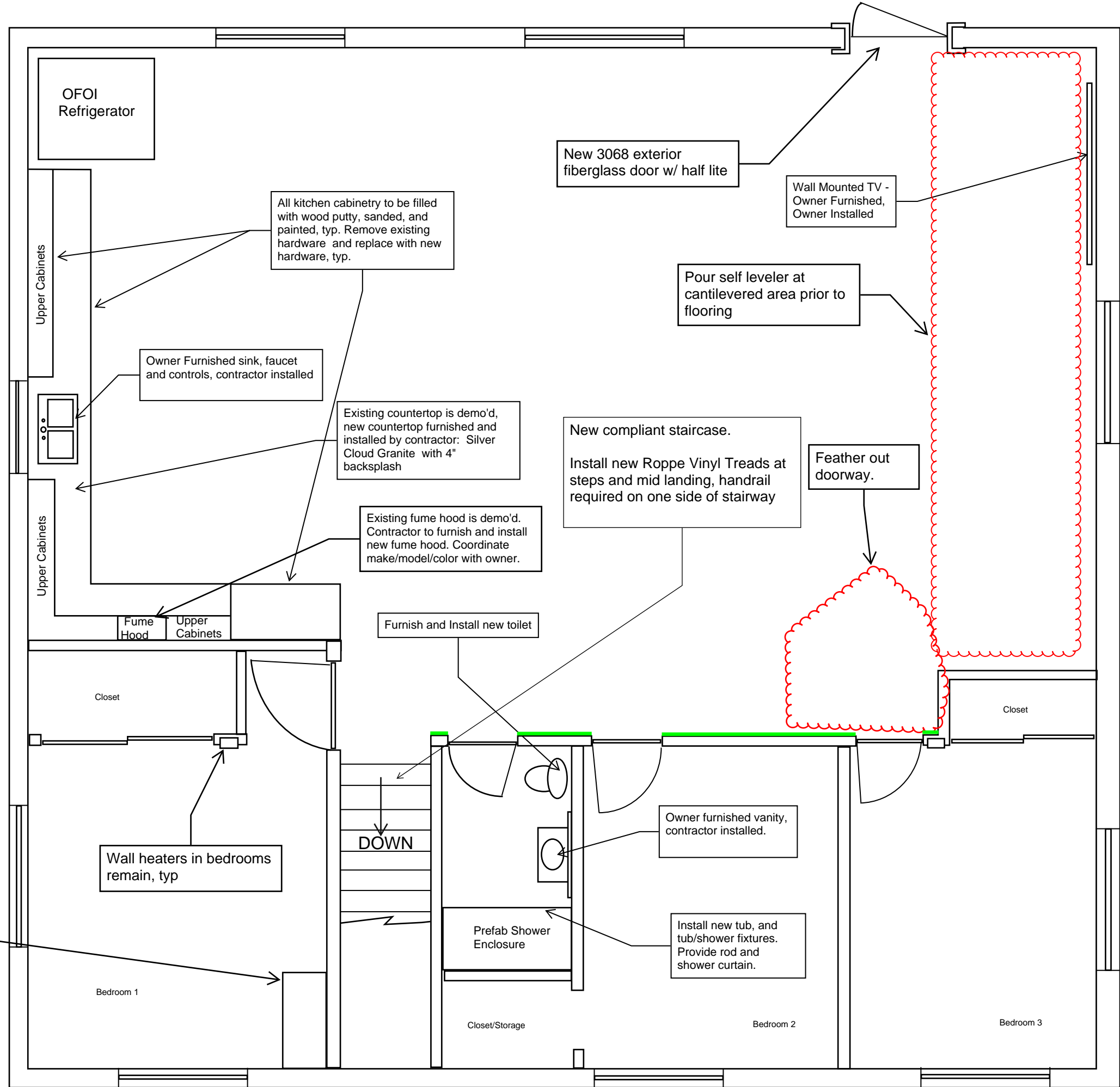

Second Floor - Floorplan

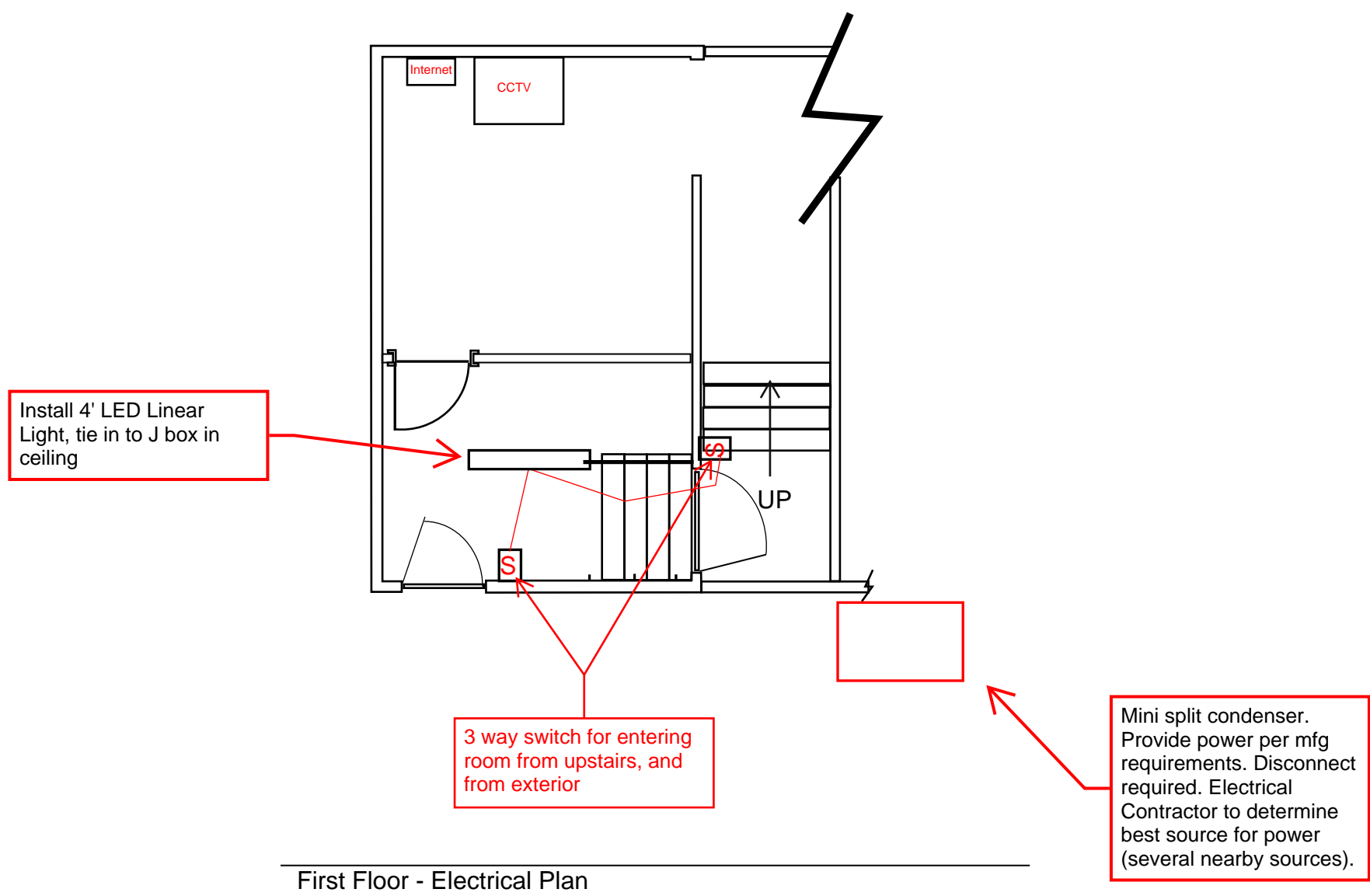

First Floor - Electrical Plan

⊖ = duplex outlet

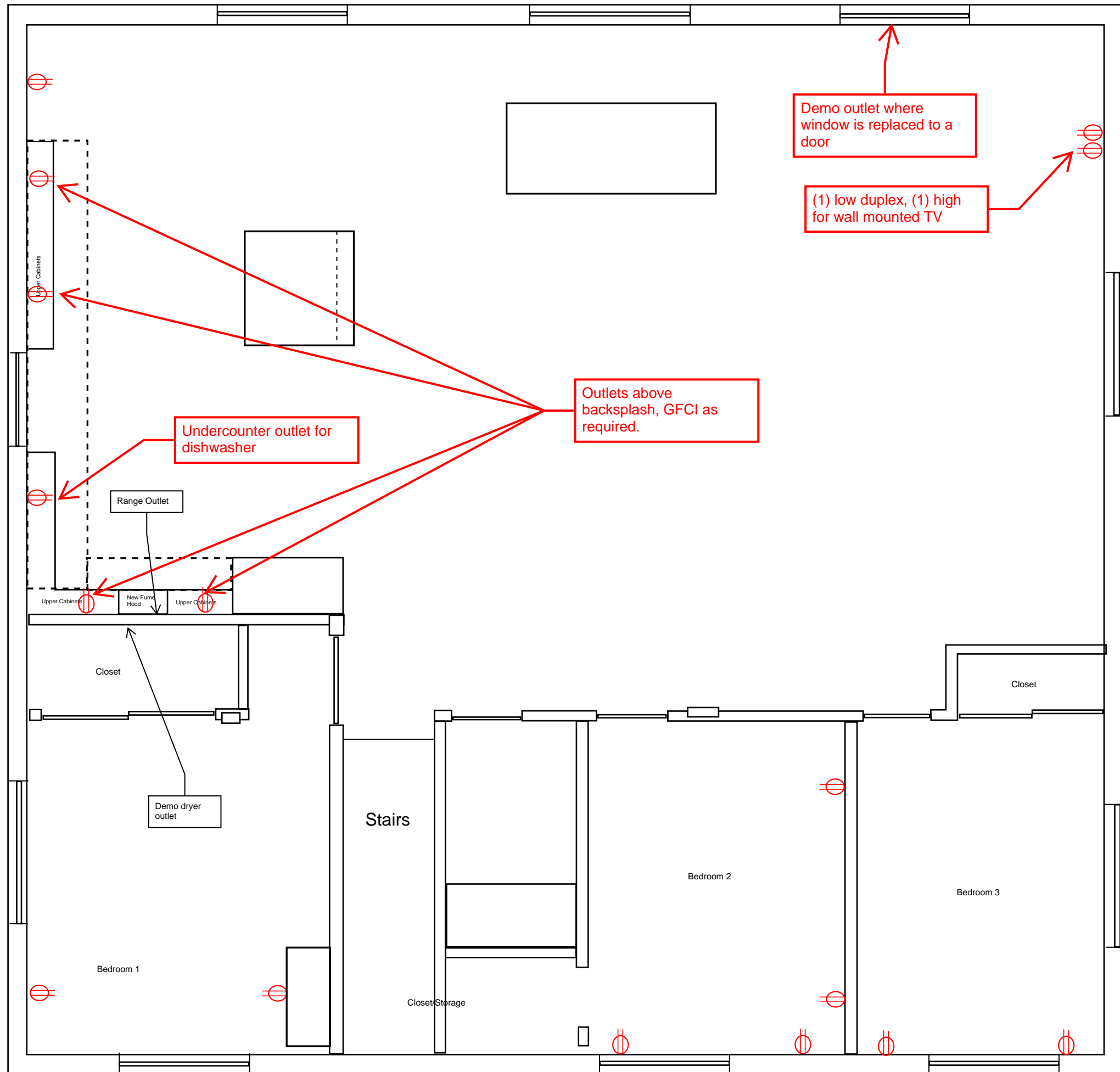



- General Notes:
1. Electrical is a design/build scope to include electrical floorplan, single line diagram, load calcs, and panel schedule.
  2. Outlets can be shifted depending on stud layout. The intent of the shown outlets is to show general locations.
  3. Any outlets not shown but required by code, is a part of the design/build electrical scope of work.

Ceiling Height = 8' in all rooms

 = OFCI Accent Light for Art Wall

 = OFCI Dimmable Can Lights

 = CFCI Pendant Light

 = OFCI Bedroom Decorative Light

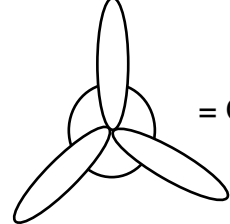
 = OFCI Lighted Ceiling Fan

 = OFCI Stair Wall Light

- General Notes:
1. Electrical is a design/build scope. to include electrical floorplan, single line diagram, load calcs, and panel schedule.
  2. Lighting to be switched as shown

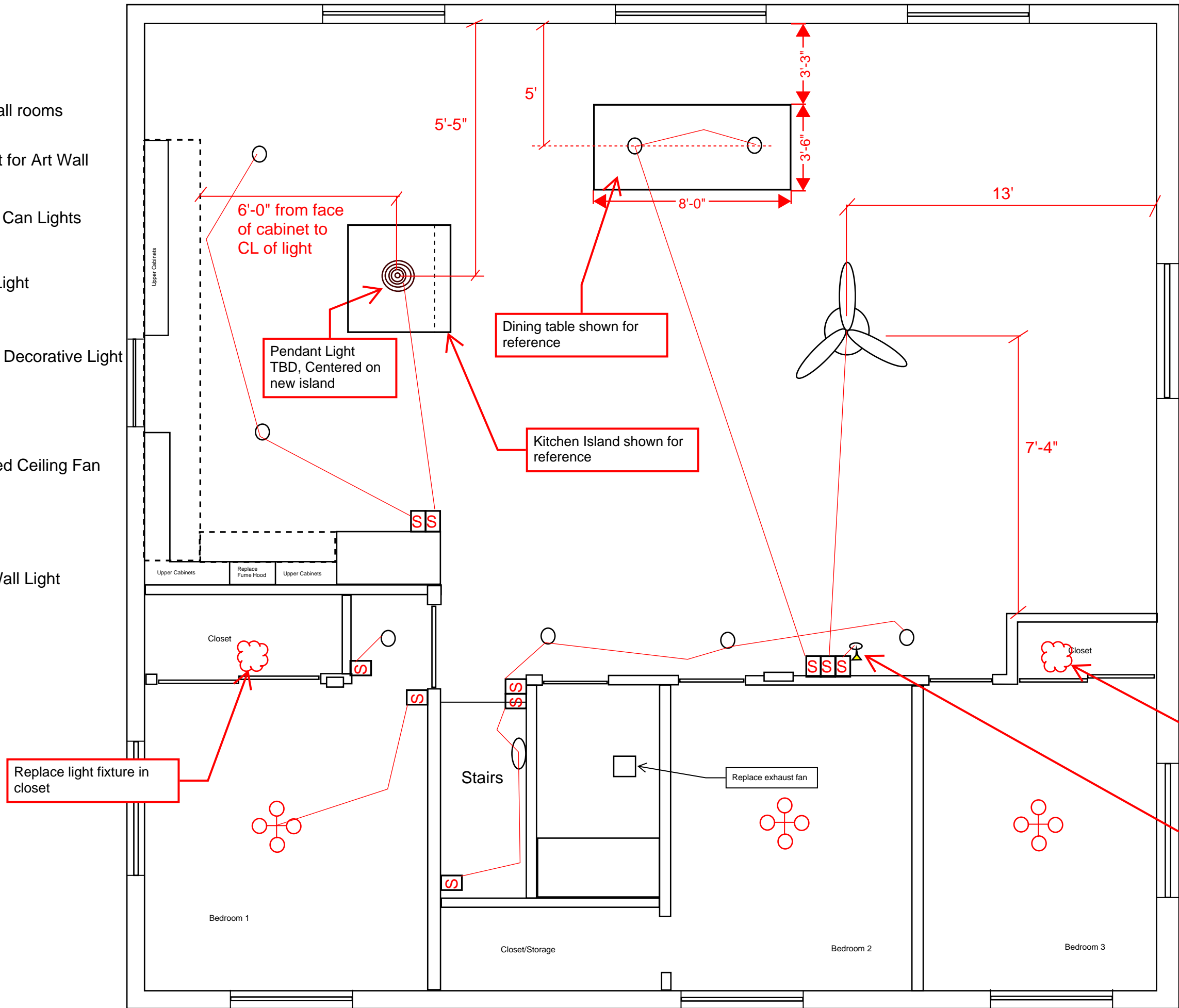

Second Floor - Reflective Ceiling Plan

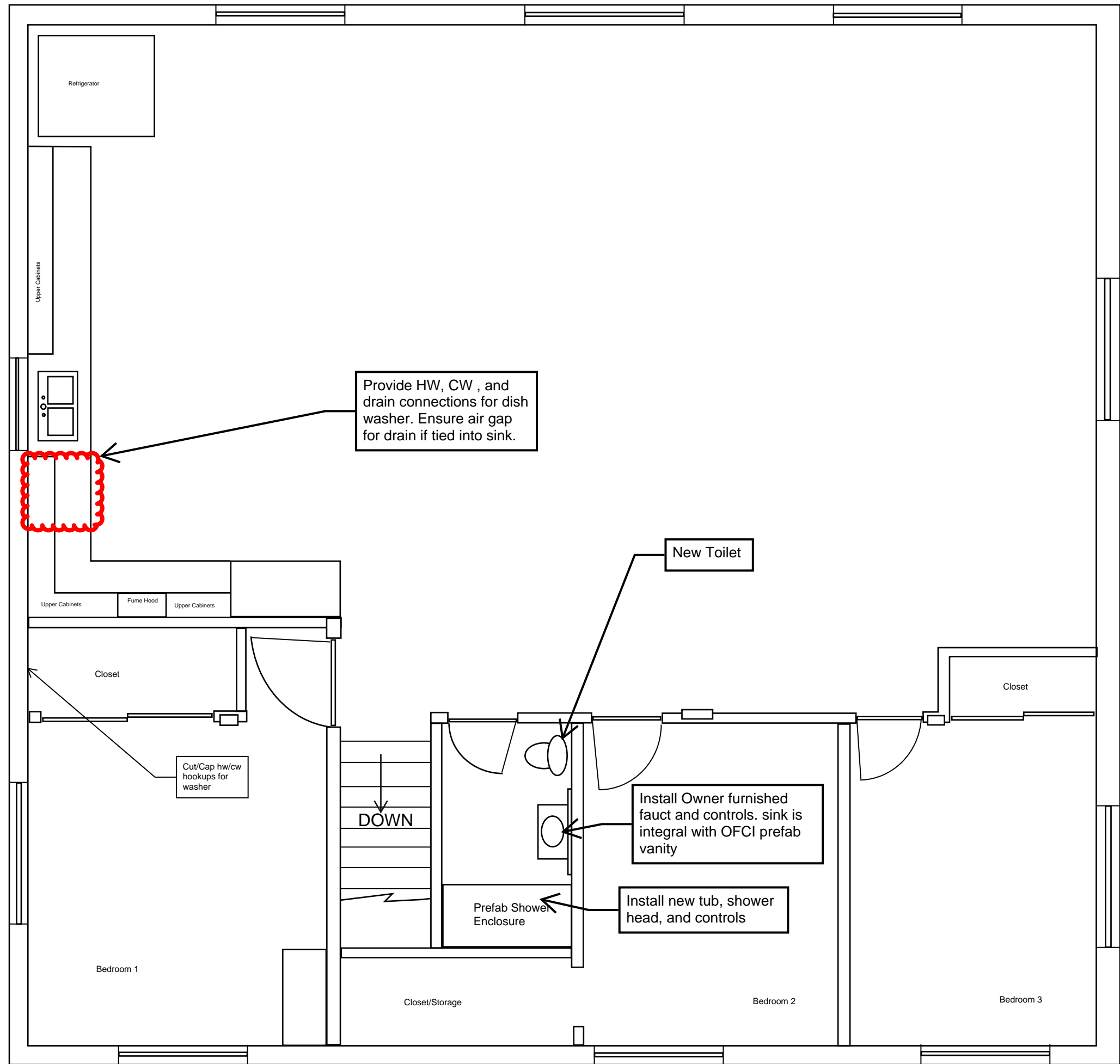

Refrigerator

Upper Cabinets

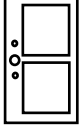

Provide HW, CW, and drain connections for dish washer. Ensure air gap for drain if tied into sink.

Upper Cabinets

Fume Hood

Upper Cabinets

Closet

Cut/Cap hw/cw hookups for washer

DOWN

New Toilet

Install Owner furnished faucet and controls. sink is integral with OFCI prefab vanity

Prefab Shower Enclosure

Install new tub, shower head, and controls

Closet

Bedroom 1

Closet/Storage

Bedroom 2

Bedroom 3

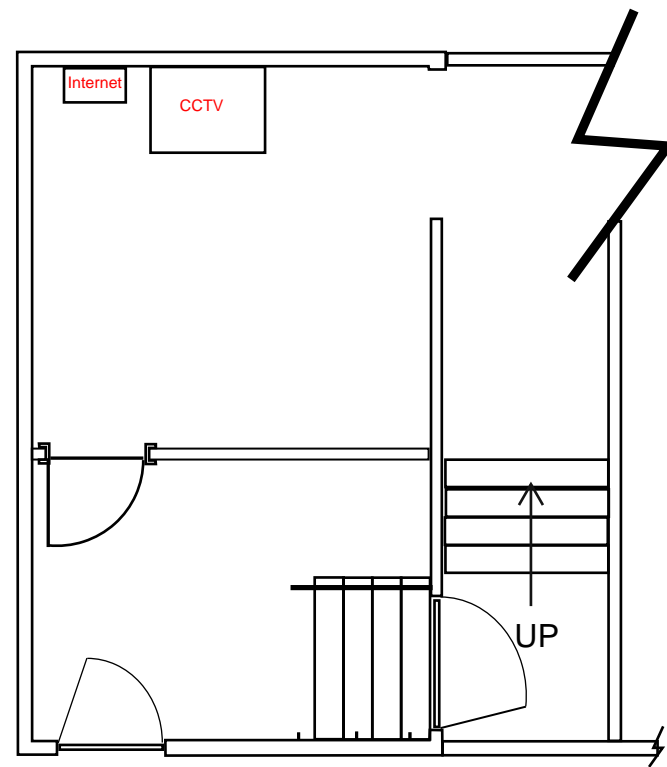

Mini split with (1) head unit. Contractor to determine correct size of unit. Locate exact placement and line set routing with owner.

First Floor - HVAC Plan

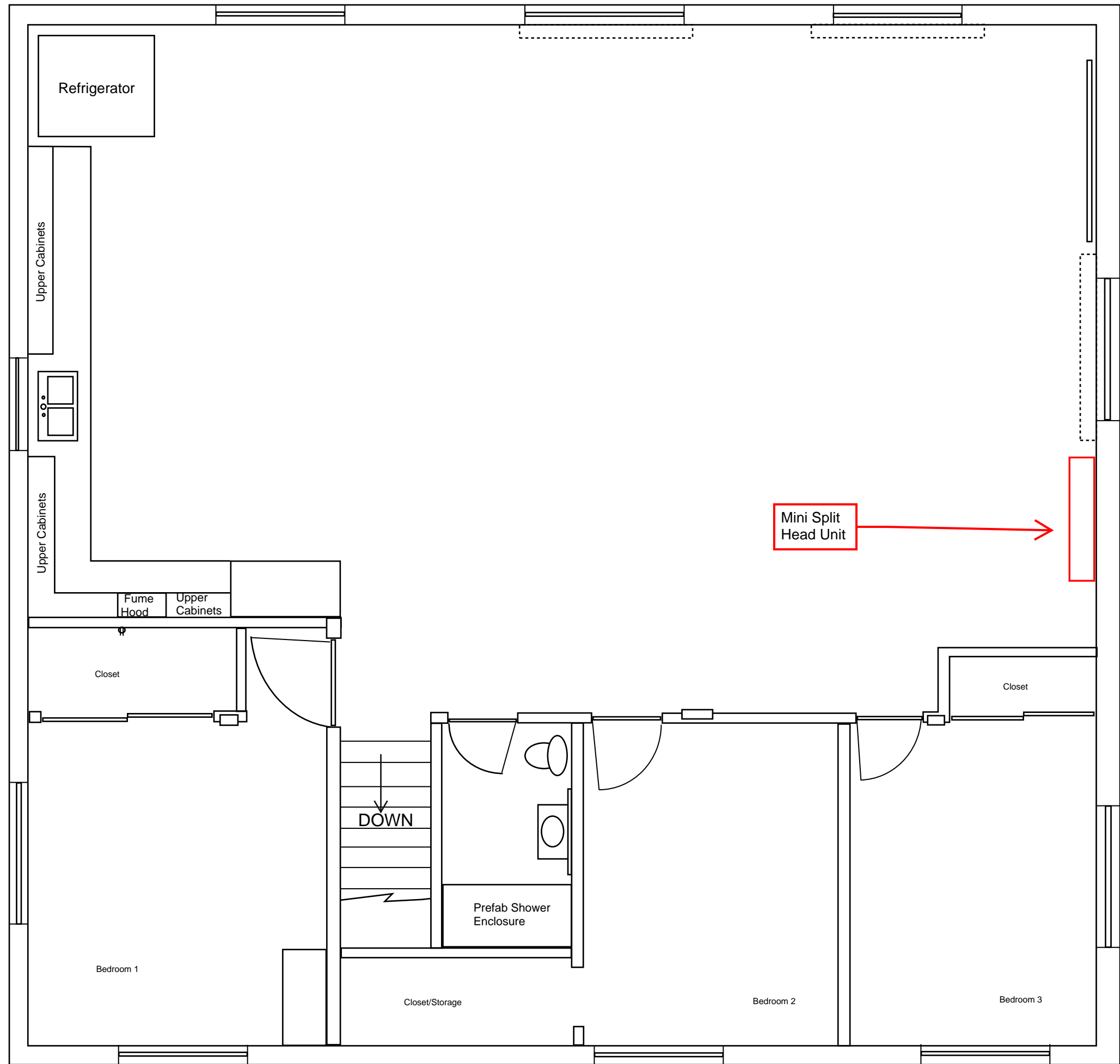

Mini Split  
Head Unit



Second Floor - HVAC Plan

1. All Items in Blue are Owner Furnished, Owner Installed. This sheet is for reference only. Confirm MEP connections with owner prior to rough in.

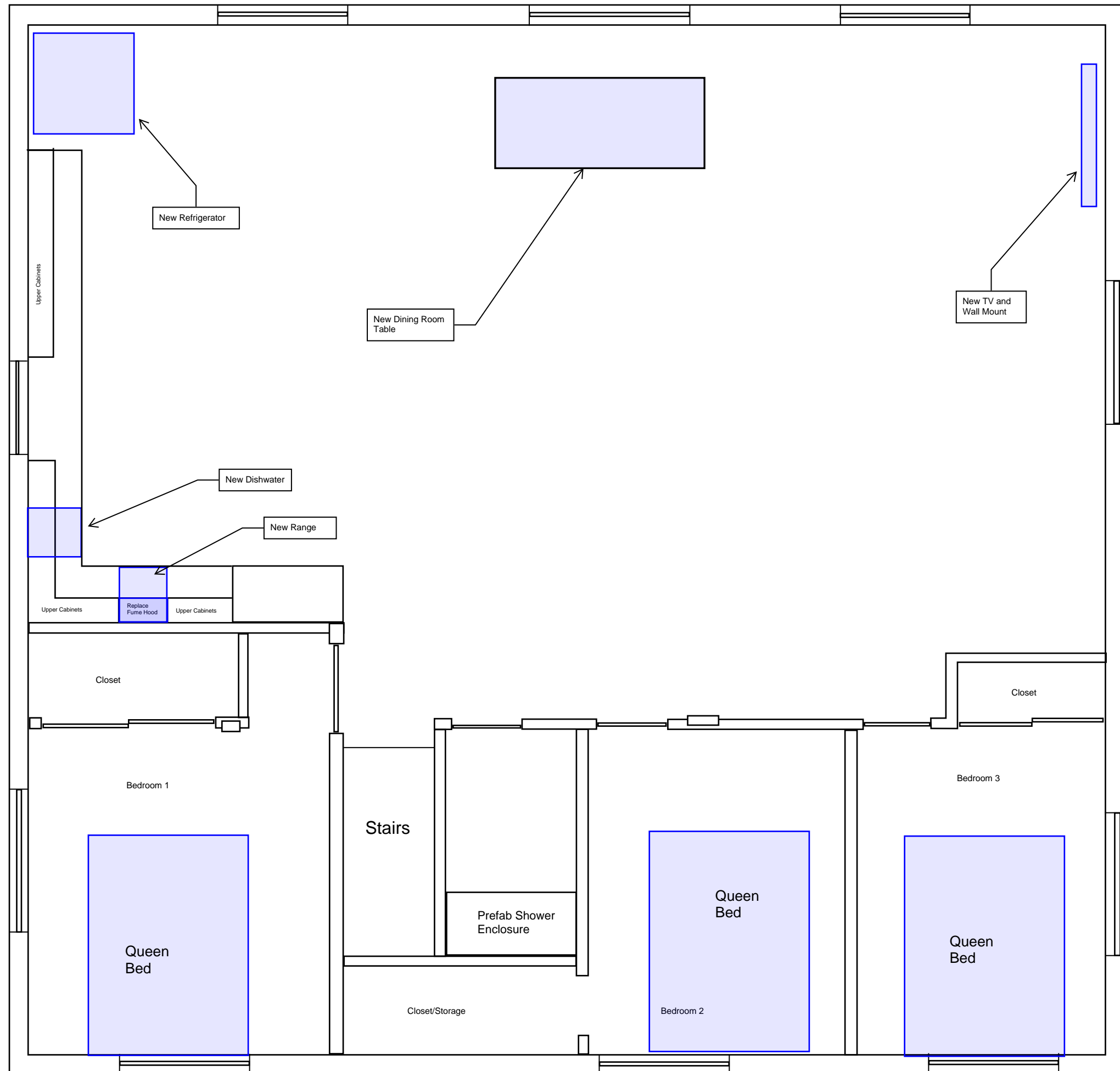

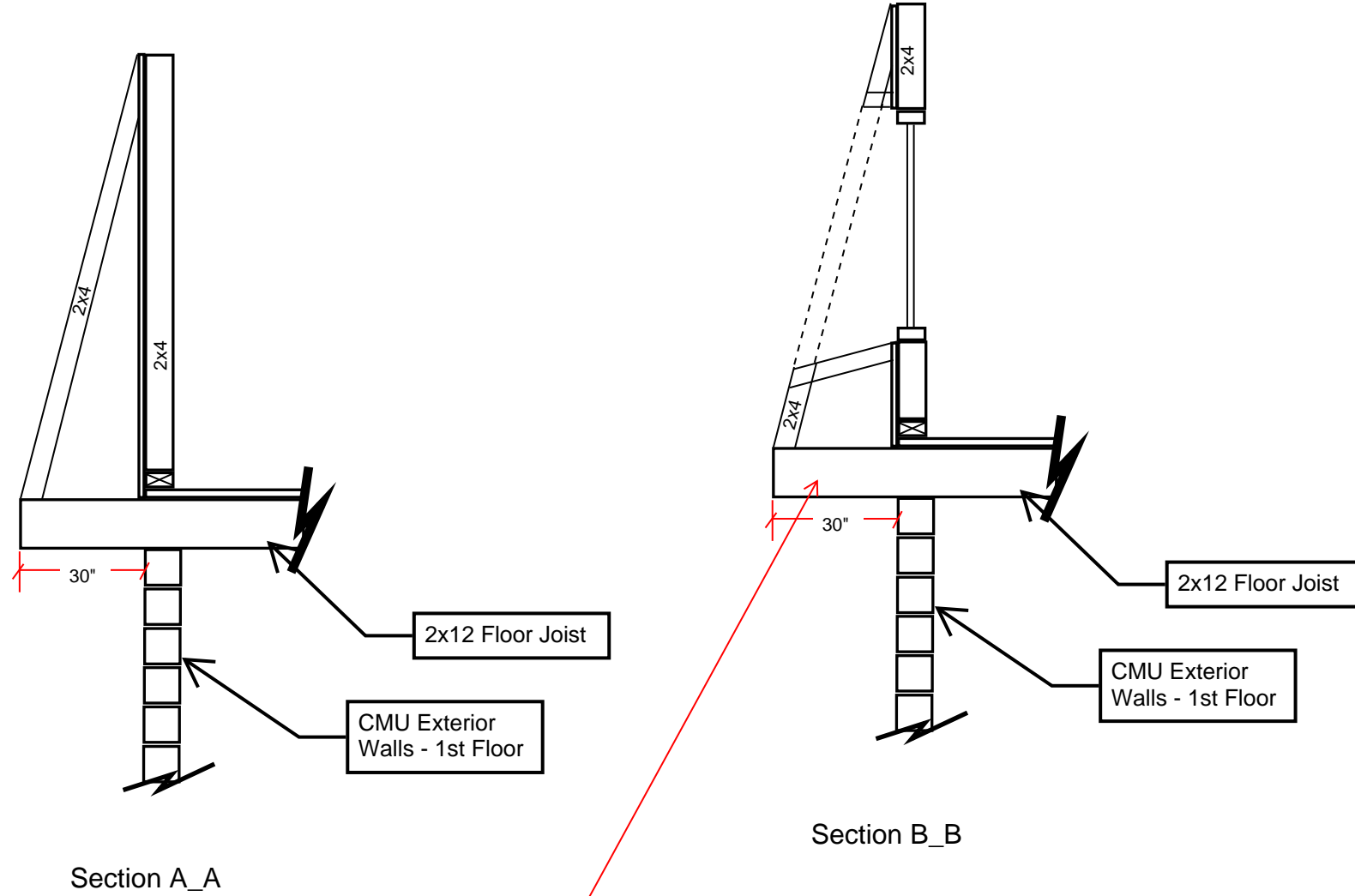

Demo cantilevered 2x12 joists at new deck, currently there is a 30" cantilever

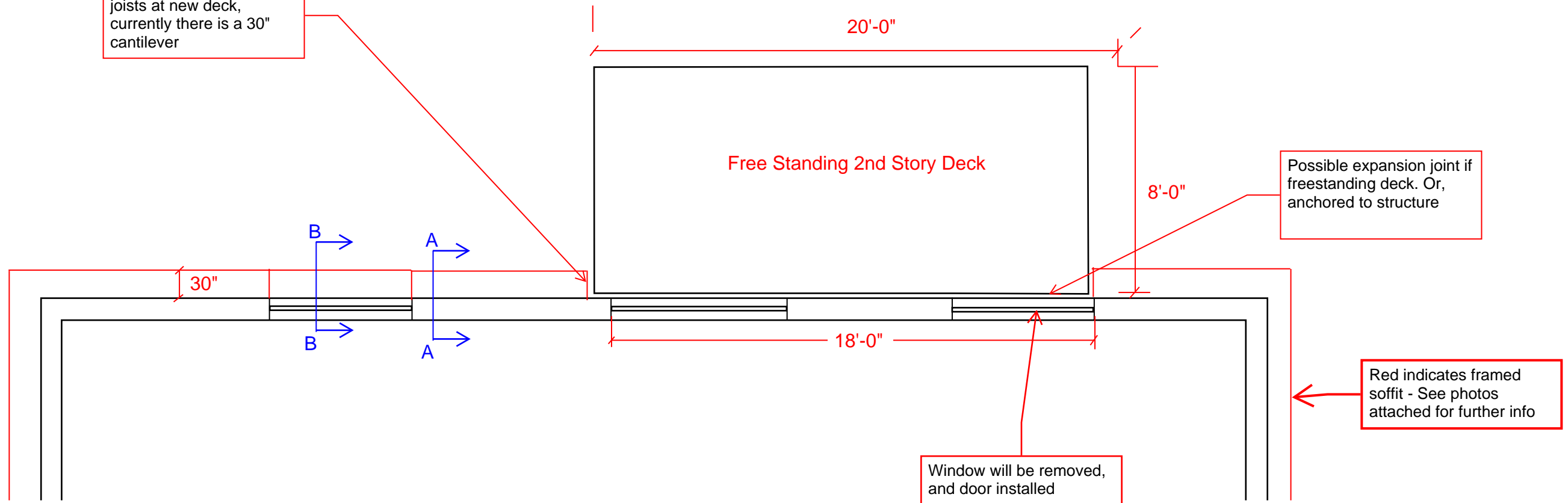

Exterior Deck Plan

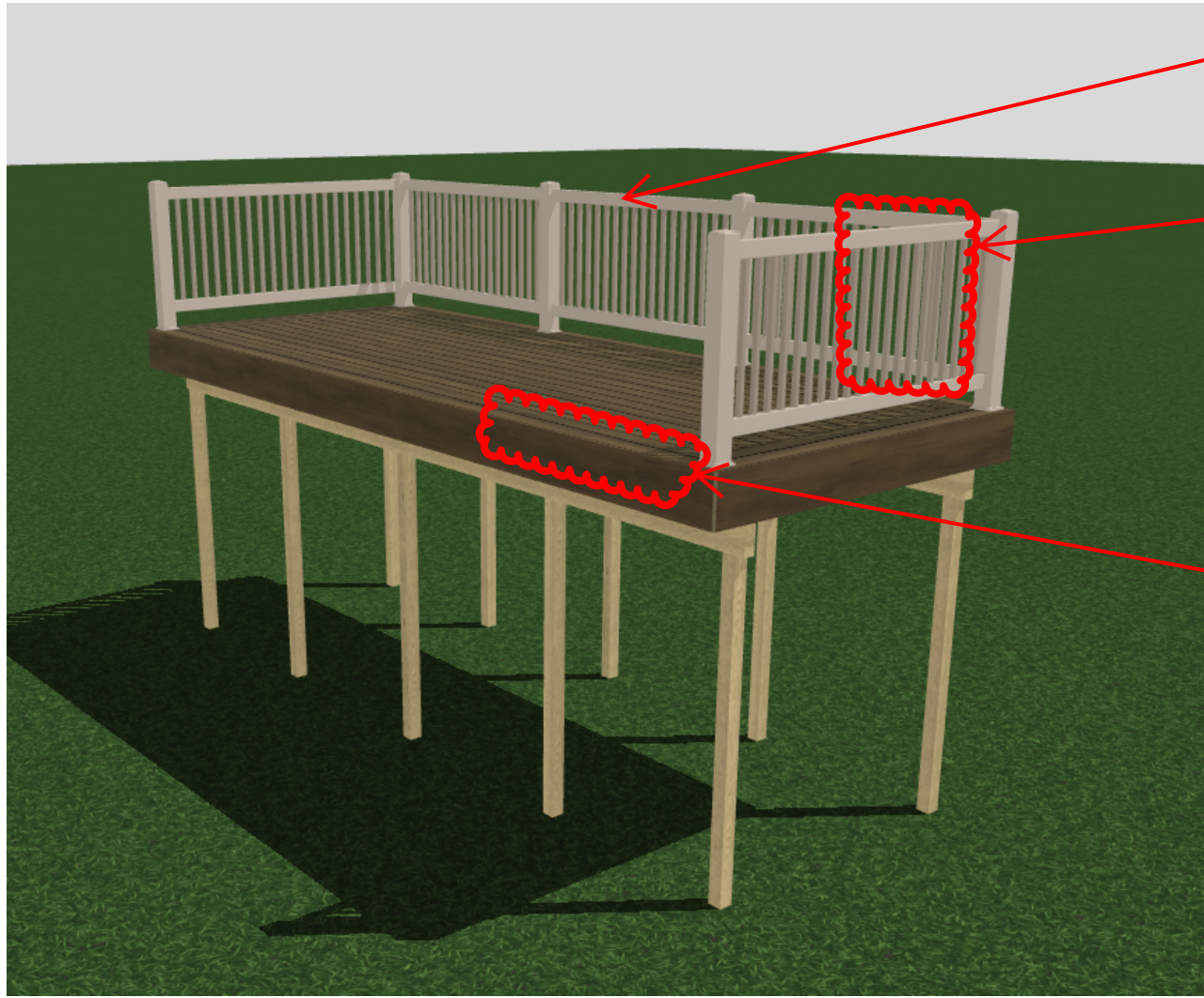

Cable Railing system

Need a fixed ladder for fire escape

Expansion joint at doorway if free standing deck. Or, we anchor to structure without a gap

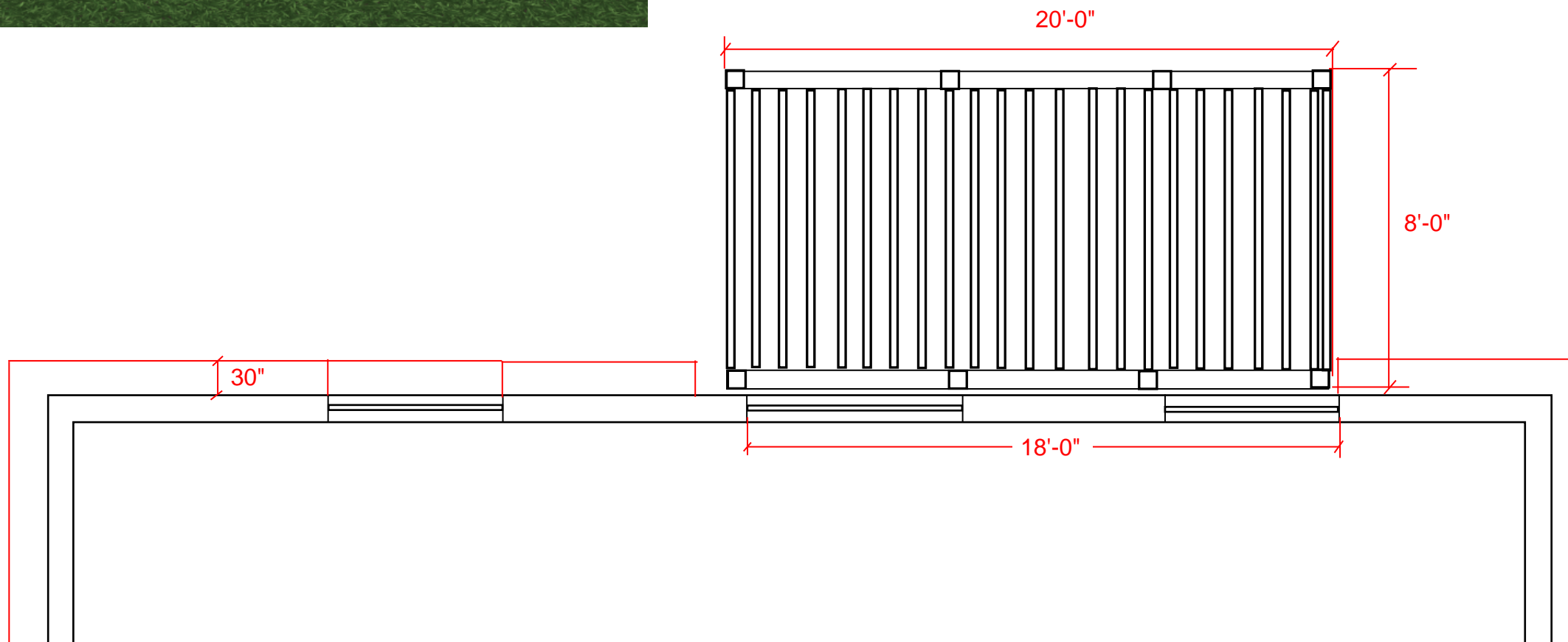

Exterior Deck Plan

**RESOLUTION NO. 2026-31**

**A RESOLUTION OF THE CITY COUNCIL OF THE CITY OF CRESCENT CITY AMENDING THE FISCAL YEAR 2025-26 BUDGET OF THE CITY OF CRESCENT CITY**

**WHEREAS**, the budget for the fiscal year beginning July 1, 2025 and ending June 30, 2026, as submitted by the City Manager, has been reviewed by the City Council and a duly-noticed public hearing held thereon the 16<sup>th</sup> day of June 2025; and

**WHEREAS**, the City Council adopted said budget by way of Resolution No. 2025-24 and has the authority to amend said budget from time to time; and

**WHEREAS**, the City owns and is responsible for maintenance of Lighthouse Cove RV Park; and

**WHEREAS**, the City of Crescent City relies on the RV Park being a self-sustaining facility; and

**WHEREAS**, the City received a State Coastal Conservancy grant for improvements at Lighthouse Cove RV Park, including the installation of two ADA cabins, refurbishment of the two park restrooms, and updating the upstairs apartment so it can be utilized as a short-term rental unit; and

**WHEREAS**, the City needs to perform unforeseen health and safety improvements to the apartment beyond the grant award budget, which will also increase the units amenities by providing an exterior deck with an emergency exit, improved electrical, heating, and cooling systems, and the complete abatement of any remaining asbestos found within the apartment; and

**WHEREAS**, staff propose to utilize \$200,000 of the RV Park’s working capital balance to fund this increased scope of work; and

**WHEREAS**, fulfillment of these priorities requires an amendment to the City’s Fiscal Year 2025-26 budget.

**NOW, THEREFORE, BE IT RESOLVED BY THE CITY COUNCIL OF THE CITY OF CRESCENT CITY AS FOLLOWS:**

1. That the Fiscal Year 2025-26 City of Crescent City Annual Budget is hereby amended and appropriated in the amounts identified below:

	Revenue Increase (Decrease)	Expenditure Increase (Decrease)
<b>RV Park Fund</b>		\$200,000

2. That the unspent portion of this capital improvement budget will be carried forward to the next fiscal year until the project is completed.

**APPROVED and ADOPTED** and made effective the same day at a meeting of the City Council of the City of Crescent City held on the 20<sup>th</sup> day of April 2026 by the following polled vote:

AYES:  
NOES:  
ABSTAIN:  
ABSENT:

\_\_\_\_\_  
Isaiah Wright, Mayor

ATTEST:

\_\_\_\_\_  
Robin Altman, City Clerk

# CITY COUNCIL AGENDA REPORT



**TO: MAYOR WRIGHT AND MEMBERS OF THE CITY COUNCIL**

**FROM: ERIC WIER, CITY MANAGER**

**DATE: APRIL 20, 2026**

**SUBJECT: LETTER OF SUPPORT FOR SB 1216 (CABALDON): PLANNING AND ZONING LAW, HOUSING LEADERSHIP DESIGNATION**

---

## **RECOMMENDATION**

- Hear staff report
- Technical questions from the Council
- Receive public comment
- Further Council discussion
- Approve and authorize the Mayor to sign a letter of support for SB 1216 (Cabaldon): Planning and Zoning Law, Housing Leadership Designation

## **BACKGROUND**

On April 9, 2026, Timothy Knox, Legislative Aide for Senator Christopher Cabaldon, wrote asking for the Council to issue a letter of support for SB 1216. This bill would establish a Housing Leadership Designation for jurisdictions that have demonstrated a strong commitment to housing production. Based on our jurisdiction's permitting record, Mr. Knox stated that the City would qualify for this designation. The designation rewards jurisdictions that are already leading, with benefits such as formal State recognition and greater local discretion over community planning decisions.

## **ITEM ANALYSIS**

Jurisdictions that receive the Housing Leadership Designation would be afforded some flexibility when it comes to state-mandated housing laws. In summary, those jurisdictions would have:

1. Authority to modify or exempt themselves from SB 9 lot split requirements, provided they continue to allow ministerial approval of at least two units on qualifying parcels.
2. Authority to modify density bonus parking requirements and the number of incentives or concessions, while maintaining minimum density bonuses.
3. An extended cure period (90 days instead of immediate fines) when notified of potential violations of housing reform laws by the Attorney General or Department of Housing and Community Development.

SB 1216 does not add any additional requirements on the City. However, if the City qualifies for a Housing Leadership Designation, it will gain the ability to exempt or modify the City from some of the state mandates pertaining to housing development (as mentioned above).

## **FISCAL ANALYSIS**

Authorizing a letter of support for SB 1216 will not have a fiscal impact.

**STRATEGIC PLAN ASSESSMENT**

This action supports the following Strategic plan Goals:

- GOAL 1: SUPPORT QUALITY SERVICES, COMMUNITY SAFETY, AND HEALTH TO ENHANCE THE QUALITY OF LIFE AND EXPERIENCE OF OUR RESIDENTS AND VISITORS

**ATTACHMENTS**

1. Draft Letter of support
2. SB 1216 Fact Sheet
3. SB 1216 as amended April 13, 2026



## *City of Crescent City*

*Where the Redwoods Meet the Sea*

377 J Street, Crescent City, CA 95531 • 707.464.7483 • Fax 707.465.4405 • [www.crescentcity.org](http://www.crescentcity.org)



April 20, 2026

The Honorable Jesse Arreguín  
Chair, Senate Housing Committee  
1021 O Street, Suite 3330  
Sacramento, CA 95814

RE: Support for SB 1216 (Cabaldon): Planning and Zoning Law, Housing Leadership Designation.

To The Honorable Jesse Arreguin:

On behalf of the City Council of the City of Crescent City, I write to express our support for SB 1216 (Cabaldon), which establishes a Housing Leadership Designation Program to recognize and reward jurisdictions that demonstrate exceptional housing production outcomes with meaningful regulatory flexibility.

We support SB 1216 because it advances a practical, outcomes-based framework that aligns state objectives with local implementation. For too long, California's housing laws have treated all jurisdictions the same, rewarding compliance on paper while paying little attention to whether homes are actually getting built. SB 1216 changes that by distinguishing jurisdictions that are delivering real results and giving them the trust and discretion they have earned.

SB 1216's performance-based approach is particularly meaningful to us because it provides an incentive structure that reinforces what effective jurisdictions are already working to accomplish: increasing housing supply while maintaining strong planning standards and community outcomes. By tying regulatory flexibility directly to demonstrated production, the bill creates a constructive pathway for local governments to reduce friction and direct resources toward housing delivery.

For these reasons, the City of Crescent City of California, is pleased to support SB 1216. Thank you for your leadership in advancing solutions that recognize performance, encourage housing production, and strengthen the partnership between the State and local jurisdictions.

Sincerely,

Isaiah Wright, Mayor  
City of Crescent City

## SB 1216 – Housing Leadership Designation Program

### IN BRIEF

---

SB 1216 establishes a Housing Leadership Designation Program (HLDP) to recognize and reward cities and counties that demonstrate exceptional housing production outcomes with regulatory flexibility.

The bill establishes performance-based thresholds scaled to local affordability challenges, measuring jurisdictions on a sliding scale tied to their affordability and production levels.

### BACKGROUND

---

Existing law establishes the Prohousing Designation Program (PDP) to recognize cities and counties that adopt prohousing local policies and provide preferential treatment in competitive state funding programs.

The PDP evaluates jurisdictions based on the adoption of specific policies intended to accelerate housing production. Jurisdictions receive the designation by demonstrating they have adopted a threshold number of qualifying policies. The program operates on the principle that good policies will lead to good outcomes.

However, policy adoption alone does not guarantee actual housing production, and the program does not directly measure whether designated jurisdictions are successfully building housing at the scale needed to address California's affordability crisis.

### THE ISSUE

---

California's housing laws do not distinguish between jurisdictions that are solving the problem and those that are not. Jurisdictions with proven track records of building housing at scale are subject to the same rigid requirements as jurisdictions that minimally comply without delivering results.

Regulatory flexibility should go to jurisdictions that demonstrate they can be trusted with it. Jurisdictions that achieve exceptional housing

production outcomes, particularly in the most unaffordable areas, should have authority to tailor state mandates to local conditions. Meanwhile, jurisdictions that fail to deliver meaningful production should remain subject to baseline state requirements.

### THE SOLUTION

---

This bill establishes the HLDP that rewards exceptional housing production with targeted regulatory flexibility.

To qualify for HLDP, jurisdictions must have submitted complete annual progress reports for the past five years and meet production thresholds that vary based on local affordability:

- Affordable jurisdictions (price-to-income ratio below 5:1): 5 housing units per 1,000 residents annually
- Unaffordable jurisdictions (ratio 5:1 to 10:1): 7.5 housing units per 1,000 residents annually
- Extremely unaffordable jurisdictions (ratio above 10:1): 10 housing units per 1,000 residents annually

Jurisdictions with HLDP have demonstrated the record necessary to tailor certain state housing mandates to local conditions, including:

- Authority to modify or exempt themselves from SB 9 lot split requirements, provided they continue to allow ministerial approval of at least two units on qualifying parcels.
- Authority to modify density bonus parking requirements and the number of incentives or concessions, while maintaining minimum density bonuses.
- Extended cure period (90 days instead of immediate fines) when notified of potential violations of housing reform laws by the Attorney General or Department of Housing and Community Development.

### SUPPORT

---

- CA YIMBY (Sponsor)
- City of Pico Rivera
- Greenbelt Alliance

- Neighborhood Partnership Housing Services (NPHS)
- South Pasadena Residents for Responsible Growth
- Student Homes Coalition

**FOR MORE INFORMATION**

---

Timothy Knox  
Timothy.Knox@sen.ca.gov  
916-651-4003



## SB-1216 Planning and Zoning Law: housing leadership designation. (2025-2026)

SHARE THIS:



Date Published: 04/13/2026 09:00 PM

AMENDED IN SENATE APRIL 13, 2026

CALIFORNIA LEGISLATURE— 2025–2026 REGULAR SESSION

**SENATE BILL**

**NO. 1216**

**Introduced by Senator Cabaldon**

**February 19, 2026**

An act to *amend Sections 65583, 65585, and 65585.03 of, and to* add Section 65589.10 ~~to~~ *to*, the Government Code, relating to housing.

### LEGISLATIVE COUNSEL'S DIGEST

SB 1216, as amended, Cabaldon. Planning and Zoning Law: housing leadership designation.

Existing law, the Planning and Zoning Law, requires each county and city to adopt a comprehensive, long-term general plan for the physical development of the county or city, and specified land outside its boundaries, that includes, among other specified mandatory elements, a housing element. Existing law requires the Department of Housing and Community Development to determine whether the housing element is in substantial compliance with those provisions, as provided. Existing law requires the department to designate jurisdictions as prohousing pursuant to emergency regulations adopted by the department, as prescribed, and requires that jurisdictions that are prohousing and that are in substantial compliance with specified provisions be awarded additional points or preference in the scoring of applications for specified state programs.

This bill would require the department, on or before July 1 of each year, to publish a list of housing leadership designated jurisdictions on its internet website. To qualify for a housing leadership designation, the bill would require that the jurisdiction have submitted a complete annual progress report for the preceding 5 years and, as applicable, that it meet specified requirements relating to housing production that vary based on whether the jurisdiction is an affordable jurisdiction, an unaffordable jurisdiction, or an extremely unaffordable jurisdiction, as those terms are defined. The bill would also require the department to publish a list of the affordability designation for each jurisdiction that has submitted a complete annual progress report, as provided. The bill would authorize a jurisdiction with a housing leadership designation to take prescribed actions, including to establish by ordinance an exemption or modification of specified provisions of the Planning and Zoning Law. *The bill would require that a housing element or amendment be considered in substantial compliance when the local agency adopts the housing element or amendment for the current planning period, and a jurisdiction adopts a*

*housing element under these provisions and the department had not issued contrary written findings within 30 days of receiving notice of the legislative body's resolution. The bill would also exempt a jurisdiction with a housing leadership designation from requirements to include specified analyses in the housing element.* The bill would include findings that changes proposed by this bill address a matter of statewide concern rather than a municipal affair and, therefore, apply to all cities, including charter cities.

Vote: majority Appropriation: no Fiscal Committee: yes Local Program: no

THE PEOPLE OF THE STATE OF CALIFORNIA DO ENACT AS FOLLOWS:

**SECTION 1.** *Section 65583 of the Government Code is amended to read:*

**65583.** The housing element shall consist of an identification and analysis of existing and projected housing needs and a statement of goals, policies, quantified objectives, financial resources, and scheduled programs for the preservation, improvement, and development of housing. The housing element shall identify adequate sites for housing, including rental housing, factory-built housing, mobilehomes, and emergency shelters, and shall make adequate provision for the existing and projected needs of all economic segments of the community. The housing element shall contain all of the following:

(a) An assessment of housing needs, and an inventory of resources and constraints that are relevant to the meeting of those needs. The assessment and inventory shall include all of the following:

(1) An analysis of population and employment trends and documentation of projections and a quantification of the locality's existing and projected housing needs for all income levels. These existing and projected needs shall include the locality's share of the regional housing need in accordance with Section 65584.

(2) An analysis and documentation of household characteristics, including level of payment compared to ability to pay, housing characteristics, including overcrowding, and housing stock condition.

(3) An inventory of land suitable and available for residential development, including vacant sites and sites having realistic and demonstrated potential for redevelopment during the planning period to meet the locality's housing need for a designated income level, and an analysis of the relationship of zoning and public facilities and services to these sites, and an analysis of the relationship of the sites identified in the land inventory to the jurisdiction's duty to affirmatively further fair housing.

(4) (A) The identification of one or more zoning designations that allow residential uses, including mixed uses, where emergency shelters are allowed as a permitted use without a conditional use or other discretionary permit and that are suitable for residential uses. The identified zoning designations shall include sufficient sites meeting the requirements of subparagraph (H) with sufficient capacity, as described in subparagraph (I), to accommodate the need for emergency shelter identified in paragraph (7), except that each local government shall identify a zoning designation or designations that can accommodate at least one year-round emergency shelter. If the local government cannot identify a zoning designation or designations with sufficient capacity, the local government shall include a program to amend its zoning ordinance to meet the requirements of this paragraph within one year of the adoption of the housing element. The local government may identify additional zoning designations where emergency shelters are permitted with a conditional use permit. The local government shall also demonstrate that existing or proposed permit processing, development, and management standards that apply to emergency shelters are objective and encourage and facilitate the development of, or conversion to, emergency shelters.

(B) Emergency shelters shall only be subject to the following written, objective standards:

(i) The maximum number of beds or persons permitted to be served nightly by the facility.

(ii) Sufficient parking to accommodate all staff working in the emergency shelter, provided that the standards do not require more parking for emergency shelters than other residential or commercial uses within the same zone.

(iii) The size and location of exterior and interior onsite waiting and client intake areas.

(iv) The provision of onsite management.

(v) The proximity to other emergency shelters, provided that emergency shelters are not required to be more than 300 feet apart.

(vi) The length of stay.

(vii) Lighting.

(viii) Security during hours that the emergency shelter is in operation.

(C) For purposes of this paragraph, "emergency shelter" shall include other interim interventions, including, but not limited to, a navigation center, bridge housing, and respite or recuperative care, and all services provided onsite, including the addition or expansion of services that are consistent with any written, objective standards pursuant to subparagraph (B).

(D) The permit processing, development, and management standards applied under this paragraph shall not be deemed to be discretionary acts within the meaning of the California Environmental Quality Act (Division 13 (commencing with Section 21000) of the Public Resources Code).

(E) If a local government has adopted written, objective standards pursuant to subparagraph (B), the local government shall include an analysis of the standards in the analysis of constraints pursuant to paragraph (5).

(F) A local government that can demonstrate, to the satisfaction of the department, the existence of one or more emergency shelters either within its jurisdiction or pursuant to a multijurisdictional agreement that can accommodate that jurisdiction's need and the needs of the other jurisdictions that are a part of the agreement for emergency shelter identified in paragraph (7) may comply with the zoning requirements of subparagraph (A) by identifying a zoning designation where new emergency shelters are allowed with a conditional use permit.

(G) A local government with an existing ordinance or ordinances that comply with this paragraph shall not be required to take additional action to identify zoning designations for emergency shelters. The housing element must only describe how existing ordinances, policies, and standards are consistent with the requirements of this paragraph.

(H) The zoning designation or designations where emergency shelters are allowed, as described in subparagraph (A), shall include sites that meet at least one of the following standards:

(i) Vacant sites zoned for residential use.

(ii) Vacant sites zoned for nonresidential use that allow residential development, if the local government can demonstrate how the sites with this zoning designation that are being used to satisfy the requirements of paragraph (1) are located near amenities and services that serve people experiencing homelessness, which may include health care, transportation, retail, employment, and social services, or that the local government will provide free transportation to services or offer services onsite.

(iii) Nonvacant sites zoned for residential use or for nonresidential use that allow residential development that are suitable for use as a shelter in the current planning period, or which can be redeveloped for use as a shelter in the current planning period. A nonvacant site with an existing use shall be presumed to impede emergency shelter development absent an analysis based on substantial evidence that the use is likely to be discontinued during the planning period. The analysis shall consider current market demand for the current uses, market conditions, and incentives or standards to encourage shelter development.

(I) The zoning designation or designations shall have sufficient sites meeting the requirements of subparagraph (H) to accommodate the need for shelters identified pursuant to paragraph (7). The number of people experiencing homelessness that can be accommodated on any site shall be demonstrated by dividing the square footage of the site by a minimum of 200 square feet per person, unless the locality can demonstrate that one or more shelters were developed on sites that have fewer square feet per person during the prior planning period or the locality provides similar evidence to the department demonstrating that the site can accommodate more people experiencing homelessness. Any standard applied pursuant to this subparagraph is intended only for calculating site capacity pursuant to this section, and shall not be construed as establishing a development standard applicable to the siting, development, or approval of a shelter.

(J) Notwithstanding subparagraph (H), a local government may accommodate the need for emergency shelters identified pursuant to paragraph (7) on sites owned by the local government if it demonstrates with substantial evidence that the sites will be made available for emergency shelter during the planning period, they are suitable for residential use, and the sites are located near amenities and services that serve people

experiencing homelessness, which may include health care, transportation, retail, employment, and social services, or that the local government will provide free transportation to services or offer services onsite.

(5) An analysis of potential and actual governmental constraints upon the maintenance, improvement, or development of housing for all income levels, including the types of housing identified in paragraph (1) of subdivision (c), and for persons with disabilities as identified in the analysis pursuant to paragraph (7), including land use controls, building codes and their enforcement, site improvements, fees, and other exactions required of developers, local processing and permit procedures, historic preservation practices and policies and an assessment of how existing and proposed historic designations affect the locality's ability to meet its share of the housing need pursuant to paragraph (1), and any locally adopted ordinances that directly impact the cost and supply of residential development.

(A) The analysis shall also demonstrate local efforts to remove governmental constraints that hinder the locality from meeting its share of the regional housing need in accordance with Section 65584 and from meeting the need for housing for persons with disabilities, supportive housing, transitional housing, and emergency shelters identified pursuant to paragraph (7).

(B) (i) For adoption of the seventh and all subsequent revisions of the housing element, the analysis shall also include a potential and actual governmental constraints disclosure statement containing both of the following:

(I) An identification of each new or amended potential or actual governmental constraint, or revision increasing the stringency of a governmental constraint, adopted after the due date of the previous housing element and before submittal of the current draft housing element to the department.

(II) An identification of any new or amended potential or actual governmental constraint, or revision increasing the stringency of a governmental constraint, that the governing body of the local government can anticipate adopting during the first three years of the planning period commencing on the date that a local agency's housing element is considered to be in substantial compliance pursuant to Section 65585.03.

(ii) For the purposes of this subparagraph, "anticipate adopting" means a legislative body of the local government had, after the due date of the previous housing element and before submittal of the current draft housing element, identified in an agenda published by a legislative body of the local government pursuant to the Ralph M. Brown Act (Chapter 9 (commencing with Section 54950) of Part 1 of Division 2 of Title 5) an action to consider the adoption, amendment, or increase in the stringency of a potential or actual governmental constraint.

(iii) This subparagraph shall not be construed to prohibit a local government from adopting, amending, or increasing the stringency of a potential or actual governmental constraint regardless of whether it was included in a potential and actual governmental constraints disclosure statement pursuant to this subparagraph.

*(C) This paragraph shall not apply to a city, county, or city and county designated as a housing leadership jurisdiction pursuant to Section 65589.10.*

(6) An analysis of potential and actual nongovernmental constraints upon the maintenance, improvement, or development of housing for all income levels, including the availability of financing, the price of land, the cost of construction, the requests to develop housing at densities below those anticipated in the analysis required by subdivision (c) of Section 65583.2, and the length of time between receiving approval for a housing development and submittal of an application for building permits for that housing development that hinder the construction of a locality's share of the regional housing need in accordance with Section 65584. The analysis shall also demonstrate local efforts to remove nongovernmental constraints that create a gap between the locality's planning for the development of housing for all income levels and the construction of that housing. *This paragraph shall not apply to a city, county, or city and county designated as a housing leadership jurisdiction pursuant to Section 65589.10.*

(7) (A) An analysis of any special housing needs, such as those of the elderly; persons with disabilities, including a developmental disability, as defined in Section 4512 of the Welfare and Institutions Code; extremely low income households; large families; farmworkers; families with female heads of households; and families and persons in need of emergency shelter. The need for emergency shelter shall be assessed based on the capacity necessary to accommodate the most recent homeless point-in-time count conducted before the start of the planning period, the need for emergency shelter based on number of beds available on a year-

round and seasonal basis, the number of shelter beds that go unused on an average monthly basis within a one-year period, and the percentage of those in emergency shelters that move to permanent housing solutions. The need for emergency shelter may be reduced by the number of supportive housing units that are identified in an adopted 10-year plan to end chronic homelessness and that are either vacant or for which funding has been identified to allow construction during the planning period. An analysis of special housing needs by a city or county may include an analysis of the need for frequent user coordinated care housing services.

(B) For the seventh and subsequent revisions of the housing element, the analysis required in subparagraph (A) shall also include an analysis of the housing needs of acutely and extremely low income households.

(8) An analysis of opportunities for energy conservation with respect to residential development. Cities and counties are encouraged to include weatherization and energy efficiency improvements as part of publicly subsidized housing rehabilitation projects. This may include energy efficiency measures that encompass the building envelope, its heating and cooling systems, and its electrical system.

(9) An analysis of existing assisted housing developments that are eligible to change from low-income housing uses during the next 10 years due to termination of subsidy contracts, mortgage prepayment, or expiration of restrictions on use. "Assisted housing developments," for the purpose of this section, shall mean multifamily rental housing that receives governmental assistance under federal programs listed in subdivision (a) of Section 65863.10, state and local multifamily revenue bond programs, local redevelopment programs, the federal Community Development Block Grant Program, or local in-lieu fees. "Assisted housing developments" shall also include multifamily rental units that were developed pursuant to a local inclusionary housing program or used to qualify for a density bonus pursuant to Section 65916.

(A) The analysis shall include a listing of each development by project name and address, the type of governmental assistance received, the earliest possible date of change from low-income use, and the total number of elderly and nonelderly units that could be lost from the locality's low-income housing stock in each year during the 10-year period. For purposes of state and federally funded projects, the analysis required by this subparagraph need only contain information available on a statewide basis.

(B) The analysis shall estimate the total cost of producing new rental housing that is comparable in size and rent levels, to replace the units that could change from low-income use, and an estimated cost of preserving the assisted housing developments. This cost analysis for replacement housing may be done aggregately for each five-year period and does not have to contain a project-by-project cost estimate.

(C) The analysis shall identify public and private nonprofit corporations known to the local government that have legal and managerial capacity to acquire and manage these housing developments.

(D) The analysis shall identify and consider the use of all federal, state, and local financing and subsidy programs that can be used to preserve, for lower income households, the assisted housing developments, identified in this paragraph, including, but not limited to, federal Community Development Block Grant Program funds, tax increment funds received by a redevelopment agency of the community, and administrative fees received by a housing authority operating within the community. In considering the use of these financing and subsidy programs, the analysis shall identify the amounts of funds under each available program that have not been legally obligated for other purposes and that could be available for use in preserving assisted housing developments.

(b) (1) A statement of the community's goals, quantified objectives, and policies relative to affirmatively furthering fair housing and to the maintenance, preservation, improvement, and development of housing.

(2) It is recognized that the total housing needs identified pursuant to subdivision (a) may exceed available resources and the community's ability to satisfy this need within the content of the general plan requirements outlined in Article 5 (commencing with Section 65300). Under these circumstances, the quantified objectives need not be identical to the total housing needs. The quantified objectives shall establish the maximum number of housing units by income category that can be constructed, rehabilitated, and conserved over a five-year time period.

(c) A program that sets forth a schedule of actions during the planning period, each with a timeline for implementation, that may recognize that certain programs are ongoing, such that there will be beneficial impacts of the programs within the planning period, that the local government is undertaking or intends to undertake to implement the policies and achieve the goals and objectives of the housing element through the administration of land use and development controls, the provision of regulatory concessions and incentives, the utilization of

appropriate federal and state financing and subsidy programs when available, and the utilization of moneys in a low- and moderate-income housing fund of an agency if the locality has established a redevelopment project area pursuant to the Community Redevelopment Law (Division 24 (commencing with Section 33000) of the Health and Safety Code). In order to make adequate provision for the housing needs of all economic segments of the community, the program shall do all of the following:

(1) Identify actions that will be taken to make sites available during the planning period with appropriate zoning and development standards and with services and facilities to accommodate that portion of the city's or county's share of the regional housing need for all income levels that could not be accommodated on sites identified in the inventory completed pursuant to paragraph (3) of subdivision (a) without rezoning, and to comply with the requirements of Section 65584.09. Sites shall be identified as needed to affirmatively further fair housing and to facilitate and encourage the development of a variety of types of housing for all income levels, including multifamily rental housing, factory-built housing, mobilehomes, housing for agricultural employees, supportive housing, single-room occupancy units, emergency shelters, and transitional housing.

(A) Where the inventory of sites, pursuant to paragraph (3) of subdivision (a), does not identify adequate sites to accommodate the need for groups of all household income levels pursuant to Section 65584, a program for rezoning of those sites, subject to the following deadlines:

(i) For the adoption of the sixth revision of the housing element, jurisdictions with an eight-year housing element planning period pursuant to Section 65588, including adoption of minimum density and development standards or, for a jurisdiction in the coastal zone, any necessary local coastal program amendments related to land use designations, changes in intensity of land use, zoning ordinances, or zoning district maps, consistent with Sections 30512, 30512.2, 30513, and 30514 of the Public Resources Code, shall be completed no later than three years after either the date the housing element is adopted pursuant to subdivision (f) of Section 65585 or the date that is 90 days after receipt of comments from the department pursuant to subdivision (b) of Section 65585, whichever is earlier, unless the deadline is extended pursuant to subdivision (f). Notwithstanding the foregoing, for a local government that fails to adopt a housing element that the department has found to be in substantial compliance with this article within 120 days of the statutory deadline in Section 65588 for adoption of the housing element, rezoning of those sites, including adoption of minimum density and development standards or, for a jurisdiction in the coastal zone, any necessary local coastal program amendments related to land use designations, changes in intensity of land use, zoning ordinances, or zoning district maps, consistent with Sections 30512, 30512.2, 30513, and 30514 of the Public Resources Code, shall be completed no later than one year from the statutory deadline in Section 65588 for adoption of the housing element.

(ii) For adoption of the seventh and all subsequent revisions of the housing element, rezonings shall be completed no later than one year from the statutory deadline in Section 65588 for adoption of the housing element.

(iii) Notwithstanding clause (ii), for the adoption of the seventh and all subsequent revisions of the housing element, rezonings shall be completed no later than three years and 90 days after the statutory deadline in Section 65588 for adoption of the housing element, unless the deadline is extended pursuant to subdivision (f). This clause shall apply only if the local government complies with all of the following:

(I) The local government submits a draft element or draft amendment to the department for review pursuant to paragraph (1) of subdivision (b) of Section 65585 at least 90 days before the statutory deadline established in Section 65588 for adoption of the housing element.

(II) The local government receives from the department findings that the draft element or draft amendment substantially complies with this article pursuant to paragraph (3) of subdivision (b) of Section 65585 on or before the statutory deadline set forth in Section 65588 for adoption of the housing element.

(III) The local government adopts the draft element or draft amendment that the department found to substantially comply with this article no later than 120 days after the statutory deadline set forth in Section 65588.

(B) Where the inventory of sites, pursuant to paragraph (3) of subdivision (a), does not identify adequate sites to accommodate the need for groups of all household income levels pursuant to Section 65584, the program shall identify sites that can be developed for housing within the planning period pursuant to

subdivision (h) of Section 65583.2. The identification of sites shall include all components specified in Section 65583.2.

(C) Where the inventory of sites pursuant to paragraph (3) of subdivision (a) does not identify adequate sites to accommodate the need for farmworker housing, the program shall provide for sufficient sites to meet the need with zoning that permits farmworker housing use by right, including density and development standards that could accommodate and facilitate the feasibility of the development of farmworker housing for low- and very low income households.

(2) (A) Assist in the development of adequate housing to meet the needs of extremely low, very low, low-, and moderate-income households.

(B) For the seventh and subsequent revisions of the housing element, the program shall also assist in the development of adequate housing to meet the needs of acutely low income households.

(3) Address and, where appropriate and legally possible, remove governmental and nongovernmental constraints to the maintenance, improvement, and development of housing, including housing for all income levels and housing for persons with disabilities. The program shall remove constraints to, and provide reasonable accommodations for housing designed for, intended for occupancy by, or with supportive services for, persons with disabilities. Transitional housing and supportive housing shall be considered a residential use of property and shall be subject only to those restrictions that apply to other residential dwellings of the same type in the same zone. Supportive housing, as defined in Section 65650, shall be a use by right in all zones where multifamily and mixed uses are permitted, as provided in Article 11 (commencing with Section 65650).

(4) Conserve and improve the condition of the existing affordable housing stock, which may include addressing ways to mitigate the loss of dwelling units demolished by public or private action.

(5) Promote and affirmatively further fair housing opportunities and promote housing throughout the community or communities for all persons regardless of race, religion, sex, marital status, ancestry, national origin, color, familial status, or disability, and other characteristics protected by the California Fair Employment and Housing Act (Part 2.8 (commencing with Section 12900) of Division 3 of Title 2), Section 65008, and any other state and federal fair housing and planning law.

(6) Preserve for lower income households the assisted housing developments identified pursuant to paragraph (9) of subdivision (a). The program for preservation of the assisted housing developments shall utilize, to the extent necessary, all available federal, state, and local financing and subsidy programs identified in paragraph (9) of subdivision (a), except where a community has other urgent needs for which alternative funding sources are not available. The program may include strategies that involve local regulation and technical assistance.

(7) Develop a plan that incentivizes and promotes the creation of accessory dwelling units that can be offered at affordable rent, as defined in Section 50053 of the Health and Safety Code, for very low, low-, or moderate-income households. For purposes of this paragraph, "accessory dwelling units" has the same meaning as "accessory dwelling unit" as defined in subdivision (a) of Section 66313.

(8) Include an identification of the agencies and officials responsible for the implementation of the various actions and the means by which consistency will be achieved with other general plan elements and community goals.

(9) Include a diligent effort by the local government to achieve public participation of all economic segments of the community in the development of the housing element, and the program shall describe this effort.

(10) (A) Affirmatively further fair housing in accordance with Chapter 15 (commencing with Section 8899.50) of Division 1 of Title 2. The program shall include an assessment of fair housing in the jurisdiction that shall include all of the following components:

(i) A summary of fair housing issues in the jurisdiction and an assessment of the jurisdiction's fair housing enforcement and fair housing outreach capacity.

(ii) An analysis of available federal, state, and local data and knowledge to identify integration and segregation patterns and trends, racially or ethnically concentrated areas of poverty and affluence, disparities in access to opportunity, and disproportionate housing needs, including displacement risk. The analysis shall identify and examine such patterns, trends, areas, disparities, and needs, both within the jurisdiction and comparing the jurisdiction to the region in which it is located, based on race and other

characteristics protected by the California Fair Employment and Housing Act (Part 2.8 (commencing with Section 12900) of Division 3 of Title 2) and Section 65008.

(iii) An assessment of the contributing factors, including the local and regional historical origins and current policies and practices, for the fair housing issues identified under clauses (i) and (ii).

(iv) An identification of the jurisdiction's fair housing priorities and goals, giving highest priority to those factors identified in clause (iii) that limit or deny fair housing choice or access to opportunity, or negatively impact fair housing or civil rights compliance, and identifying the metrics and milestones for determining what fair housing results will be achieved.

(v) Strategies and actions to implement those priorities and goals, which may include, but are not limited to, enhancing mobility strategies and encouraging development of new affordable housing in areas of opportunity, as well as place-based strategies to encourage community revitalization, including preservation of existing affordable housing, and protecting existing residents from displacement.

(B) A jurisdiction that completes or revises an assessment of fair housing pursuant to Subpart A (commencing with Section 5.150) of Part 5 of Subtitle A of Title 24 of the Code of Federal Regulations, as published in Volume 80 of the Federal Register, Number 136, page 42272, dated July 16, 2015, or an analysis of impediments to fair housing choice in accordance with the requirements of Section 91.225 of Title 24 of the Code of Federal Regulations in effect before August 17, 2015, may incorporate relevant portions of that assessment or revised assessment of fair housing or analysis or revised analysis of impediments to fair housing into its housing element.

(C) (i) The requirements of this paragraph shall apply to housing elements due to be revised pursuant to Section 65588 on or after January 1, 2021.

(ii) The assessment required pursuant to this paragraph shall be completed before the planning agency makes its first draft revision of a housing element available for public comment pursuant to subdivision (b) of Section 65585.

(D) (i) The department shall develop a standardized reporting format for programs and actions taken pursuant to this paragraph. The standardized reporting format shall enable the reporting of all of the assessment components listed in subparagraph (A) and, at a minimum, include all of the following fields:

(I) Timelines for implementation.

(II) Responsible party or parties.

(III) Resources committed from the local budget to affirmatively further fair housing.

(IV) Action areas.

(V) Potential impacts of the program.

(ii) A local government shall utilize the standardized report format developed pursuant to this subparagraph for the seventh and each subsequent revision of the housing element.

(d) (1) A local government may satisfy all or part of its requirement to identify a zone or zones suitable for the development of emergency shelters pursuant to paragraph (4) of subdivision (a) by adopting and implementing a multijurisdictional agreement, with a maximum of two other adjacent communities, that requires the participating jurisdictions to develop at least one year-round emergency shelter within two years of the beginning of the planning period.

(2) The agreement shall allocate a portion of the new shelter capacity to each jurisdiction as credit toward its emergency shelter need, and each jurisdiction shall describe how the capacity was allocated as part of its housing element.

(3) Each member jurisdiction of a multijurisdictional agreement shall describe in its housing element all of the following:

(A) How the joint facility will meet the jurisdiction's emergency shelter need.

(B) The jurisdiction's contribution to the facility for both the development and ongoing operation and management of the facility.

(C) The amount and source of the funding that the jurisdiction contributes to the facility.

(4) The aggregate capacity claimed by the participating jurisdictions in their housing elements shall not exceed the actual capacity of the shelter.

(e) Except as otherwise provided in this article, amendments to this article that alter the required content of a housing element shall apply to both of the following:

(1) A housing element or housing element amendment prepared pursuant to subdivision (e) of Section 65588 or Section 65584.02, when a city, county, or city and county submits a draft to the department for review pursuant to Section 65585 more than 90 days after the effective date of the amendment to this section.

(2) Any housing element or housing element amendment prepared pursuant to subdivision (e) of Section 65588 or Section 65584.02, when the city, county, or city and county fails to submit the first draft to the department before the due date specified in Section 65588 or 65584.02.

(f) The deadline for completing required rezoning pursuant to subparagraph (A) of paragraph (1) of subdivision (c) shall be extended by one year if the local government has completed the rezoning at densities sufficient to accommodate at least 75 percent of the units for lower income households and if the legislative body at the conclusion of a public hearing determines, based upon substantial evidence, that any of the following circumstances exists:

(1) The local government has been unable to complete the rezoning because of the action or inaction beyond the control of the local government of any other state, federal, or local agency.

(2) The local government is unable to complete the rezoning because of infrastructure deficiencies due to fiscal or regulatory constraints.

(3) The local government must undertake a major revision to its general plan in order to accommodate the housing-related policies of a sustainable communities strategy or an alternative planning strategy adopted pursuant to Section 65080.

The resolution and the findings shall be transmitted to the department together with a detailed budget and schedule for preparation and adoption of the required rezonings, including plans for citizen participation and expected interim action. The schedule shall provide for adoption of the required rezoning within one year of the adoption of the resolution.

(g) (1) If a local government fails to complete the rezoning by the deadline provided in subparagraph (A) of paragraph (1) of subdivision (c), as it may be extended pursuant to subdivision (f), except as provided in paragraph (2), a local government may not disapprove a housing development project, nor require a conditional use permit, planned unit development permit, or other locally imposed discretionary permit, or impose a condition that would render the project infeasible, if the housing development project, (A) is proposed to be located on a site required to be rezoned pursuant to the program action required by that subparagraph and, (B) complies with applicable, objective general plan and zoning standards and criteria, including design review standards, described in the program action required by that subparagraph. Any subdivision of sites shall be subject to the Subdivision Map Act (Division 2 (commencing with Section 66410)). Design review shall not constitute a "project" for purposes of Division 13 (commencing with Section 21000) of the Public Resources Code.

(2) A local government may disapprove a housing development described in paragraph (1) if it makes written findings supported by substantial evidence on the record that both of the following conditions exist:

(A) The housing development project would have a specific, adverse impact upon the public health or safety unless the project is disapproved or approved upon the condition that the project be developed at a lower density. As used in this paragraph, a "specific, adverse impact" means a significant, quantifiable, direct, and unavoidable impact, based on objective, identified written public health or safety standards, policies, or conditions as they existed on the date the application was deemed complete.

(B) There is no feasible method to satisfactorily mitigate or avoid the adverse impact identified pursuant to paragraph (1), other than the disapproval of the housing development project or the approval of the project upon the condition that it be developed at a lower density.

(3) The applicant or any interested person may bring an action to enforce this subdivision. If a court finds that the local agency disapproved a project or conditioned its approval in violation of this subdivision, the court

shall issue an order or judgment compelling compliance within 60 days. The court shall retain jurisdiction to ensure that its order or judgment is carried out. If the court determines that its order or judgment has not been carried out within 60 days, the court may issue further orders to ensure that the purposes and policies of this subdivision are fulfilled. In any such action, the city, county, or city and county shall bear the burden of proof.

(4) For purposes of this subdivision, "housing development project" means a project to construct residential units for which the project developer provides sufficient legal commitments to the appropriate local agency to ensure the continued availability and use of at least 49 percent of the housing units for very low, low-, and moderate-income households with an affordable housing cost or affordable rent, as defined in Section 50052.5 or 50053 of the Health and Safety Code, respectively, for the period required by the applicable financing.

(h) An action to enforce the program actions of the housing element shall be brought pursuant to Section 1085 of the Code of Civil Procedure.

(i) Notwithstanding any other law, the otherwise applicable timeframe set forth in paragraph (2) of subdivision (b) and subdivision (d) of Section 21080.3.1 of the Public Resources Code, and paragraph (3) of subdivision (d) of Section 21082.3 of the Public Resources Code, for a Native American tribe to respond to a lead agency and request consultation in writing is extended by 30 days for any housing development project application determined or deemed to be complete on or after March 4, 2020, and prior to December 31, 2021.

(j) On or after January 1, 2024, at the discretion of the department, the analysis of government constraints pursuant to paragraph (5) of subdivision (a) may include an analysis of constraints upon the maintenance, improvement, or development of housing for persons with a characteristic identified in subdivision (b) of Section 51 of the Civil Code. The implementation of this subdivision is contingent upon an appropriation by the Legislature in the annual Budget Act or another statute for this purpose.

***SEC. 2. Section 65585 of the Government Code is amended to read:***

**65585.** (a) In the preparation of its housing element, each city and county shall consider the guidelines adopted by the department pursuant to Section 50459 of the Health and Safety Code. Those guidelines shall be advisory to each city or county in the preparation of its housing element.

(b) (1) (A) At least 90 days prior to adoption of a revision of its housing element pursuant to subdivision (e) of Section 65588, or at least 60 days prior to the adoption of a subsequent amendment to this element, the planning agency shall submit a draft element revision or draft amendment to the department. The local government of the planning agency shall make the first draft revision of a housing element available for public comment for at least 30 days and, if any comments are received, the local government shall take at least 10 business days after the 30-day public comment period to consider and incorporate public comments into the draft revision prior to submitting it to the department. For any subsequent draft revision, the local government shall post the draft revision on its internet website and shall email a link to the draft revision to all individuals and organizations that have previously requested notices relating to the local government's housing element at least seven days before submitting the draft revision to the department.

(B) The planning agency staff shall collect and compile the public comments regarding the housing element received by the city, county, or city and county and provide these comments to each member of the legislative body before it adopts the housing element.

(C) The department shall review the draft and report its written findings to the planning agency within 90 days of its receipt of the first draft submittal for each housing element revision pursuant to subdivision (e) of Section 65588 or within 60 days of its receipt of a subsequent draft amendment or an adopted revision or adopted amendment to an element. The department shall not review the first draft submitted for each housing element revision pursuant to subdivision (e) of Section 65588 until the local government has made the draft available for public comment for at least 30 days and, if comments were received, has taken at least 10 business days to consider and incorporate public comments pursuant to paragraph (1).

(2) (A) At least 90 days prior to the initial adoption of a revision of its housing element pursuant to subdivision (e) of Section 65588, and at least 7 days prior to any subsequent adoption submittal if changes have occurred to the inventory of sites, a local government shall do both of the following:

(i) Make a draft of its inventory of sites required pursuant to paragraph (3) of subdivision (a) of Section 65583 available to the department and the public and post the draft inventory on its internet website.

(ii) Send an email to all individuals and organizations that have previously requested notices notifying them that the inventory has been updated that includes a link to the draft inventory on its website.

(B) The requirements of this paragraph shall apply to the seventh and each subsequent revision of the housing element.

(c) In the preparation of its findings, the department may consult with any public agency, group, or person. The department shall receive and consider any written comments from any public agency, group, or person regarding the draft or adopted element or amendment under review.

(d) In its written findings, the department shall determine whether the draft element or draft amendment substantially complies with this article.

(e) Prior to the adoption of its draft element or draft amendment, the legislative body shall consider the findings made by the department. If the department's findings are not available within the time limits set by this section, the legislative body may act without them.

(f) If the department finds that the draft element or draft amendment does not substantially comply with this article, the legislative body shall take one of the following actions:

(1) (A) Change the draft element or draft amendment to substantially comply with this article.

(B) Any change to a draft element or draft amendment pursuant to subparagraph (A) shall be completed in accordance with subdivision (b). This subparagraph does not constitute a change in, but is declaratory of, existing law.

(2) Adopt the draft element or draft amendment without changes. The legislative body shall include in its resolution of adoption written findings that explain the reasons the legislative body believes that the draft element or draft amendment substantially complies with this article despite the findings of the department.

*(3) Notwithstanding paragraph (2), if the city, county, or city and county has been designated as a housing leadership jurisdiction pursuant to Section 65589.10 for four of the past eight years and if the department has issued written findings pursuant to subparagraph (C) of paragraph (1) of subdivision (b), then, notwithstanding subdivision (b), the legislative body may, by resolution, adopt a draft element or draft amendment that has been revised to bring the jurisdiction's housing element into substantial compliance with this article. The resolution adopting the revised draft or draft amendment shall be adopted at a noticed public hearing, pursuant to subparagraph (A) of paragraph (2) of subdivision (b), and do both of the following:*

*(A) Include findings that identify each deficiency noted in the department's prior findings and describe how the revised element addresses each deficiency.*

*(B) Be supported by written findings prepared by the planning agency that demonstrate, with specific references to the revised element, that each statutory requirement identified by the department has been brought into substantial compliance with this article.*

*(4) A finding of substantial compliance made pursuant to paragraph (3) shall have the same force and effect as a finding of substantial compliance by the department under subdivision (h), unless the department issues contrary written findings within 30 days of receiving notice of the legislative body's resolution.*

(g) (1) Promptly following the adoption of its element or amendment, the planning agency shall submit a copy of the adopted element or amendment and any findings made pursuant to paragraph (2) of subdivision (f) to the department.

(2) This subdivision shall not be construed to excuse a legislative body from complying with subdivision (f). This paragraph does not constitute a change in, but is declaratory of, existing law.

(h) The department shall, within 60 days, review adopted housing elements or amendments and any findings pursuant to paragraph (2) *or (3)* of subdivision (f), make a finding as to whether the adopted element or amendment is in substantial compliance with this article, and report its findings to the planning agency.

(i) (1) (A) The department shall review any action or failure to act by the city, county, or city and county that it determines is inconsistent with an adopted housing element or Section 65583, including any failure to implement any program actions included in the housing element pursuant to Section 65583. The department shall issue written findings to the city, county, or city and county as to whether the action or failure to act substantially complies with this article, and provide a reasonable time no longer than 30 days for the city, county, or city and

county to respond to the findings before taking any other action authorized by this section, including the action authorized by subparagraph (C).

(B) If the department finds that the city's, county's, or city and county's action or failure to act does not substantially comply with its adopted housing element or its obligations pursuant to Section 65583, there shall be a rebuttable presumption of invalidity in any legal action challenging that action or failure to act.

(C) If the department finds that the action or failure to act by the city, county, or city and county does not substantially comply with this article, and if it has issued findings pursuant to this section that an amendment to the housing element substantially complies with this article, the department may revoke its findings until it determines that the city, county, or city and county has come into compliance with this article.

(2) The department may consult with any local government, public agency, group, or person, and shall receive and consider any written comments from any public agency, group, or person, regarding the action or failure to act by the city, county, or city and county described in paragraph (1), in determining whether the housing element substantially complies with this article.

(j) The department shall notify the city, county, or city and county and may notify the office of the Attorney General that the city, county, or city and county is in violation of state law if the department finds that the housing element or an amendment to this element, or any action or failure to act described in subdivision (i), does not substantially comply with this article or that any local government has taken an action in violation of the following:

- (1) Housing Accountability Act (Section 65589.5).
- (2) Section 65863.
- (3) Chapter 4.3 (commencing with Section 65915).
- (4) Section 65008.
- (5) Housing Crisis Act of 2019 (Chapter 654, Statutes of 2019, Sections 65941.1, 65943, and 66300).
- (6) Section 8899.50.
- (7) Section 65913.4.
- (8) Article 11 (commencing with Section 65650).
- (9) Article 12 (commencing with Section 65660).
- (10) Section 65913.11.
- (11) Section 65400.
- (12) Section 65863.2.
- (13) Chapter 4.1 (commencing with Section 65912.100).
- (14) Section 65905.5.
- (15) Chapter 13 (commencing with Section 66310).
- (16) Section 65852.21.
- (17) Section 65852.24.
- (18) Section 66411.7.
- (19) Section 65913.16.
- (20) Article 2 (commencing with Section 66300.5) of Chapter 12.
- (21) Section 65852.28.
- (22) Section 65913.4.5.

(23) Section 66499.41.

(24) Homeless Housing, Assistance, and Prevention program (Chapter 6 (commencing with Section 50216) and Chapter 6.5 (commencing with Section 50230) of Part 1 of Division 31 of the Health and Safety Code).

(25) Encampment Resolution Funding program (Chapter 7 (commencing with Section 50250) of Part 1 of Division 31 of the Health and Safety Code).

(26) Family Homelessness Challenge Grants and Technical Assistance Program (Chapter 8 (commencing with Section 50255) of Part 1 of Division 31 of the Health and Safety Code).

(27) Article 11.5 (commencing with Section 65658).

(k) Commencing July 1, 2019, prior to the Attorney General bringing any suit for a violation of the provisions identified in subdivision (j) related to housing element compliance and seeking remedies available pursuant to this subdivision, the department shall offer the jurisdiction the opportunity for two meetings in person or via telephone to discuss the violation, and shall provide the jurisdiction written findings regarding the violation. This paragraph does not affect any action filed prior to the effective date of this section. The requirements set forth in this subdivision do not apply to any suits brought for a violation or violations of paragraphs (1) and (3) to (9), inclusive, of subdivision (j).

(l) In any action or special proceeding brought by the Attorney General relating to housing element compliance pursuant to a notice or referral under subdivision (j), the Attorney General may request, upon a finding of the court that the housing element does not substantially comply with the requirements of this article pursuant to this section, that the court issue an order or judgment directing the jurisdiction to bring its housing element into substantial compliance with the requirements of this article. The court shall retain jurisdiction to ensure that its order or judgment is carried out. If a court determines that the housing element of the jurisdiction substantially complies with this article, it shall have the same force and effect, for purposes of eligibility for any financial assistance that requires a housing element in substantial compliance and for purposes of any incentives provided under Section 65589.9, as a determination by the department that the housing element substantially complies with this article.

(1) If the jurisdiction has not complied with the order or judgment after 12 months, the court shall conduct a status conference. Following the status conference, upon a determination that the jurisdiction failed to comply with the order or judgment compelling substantial compliance with the requirements of this article, the court shall impose fines on the jurisdiction, which shall be deposited into the Building Homes and Jobs Trust Fund. Any fine levied pursuant to this paragraph shall be in a minimum amount of ten thousand dollars (\$10,000) per month, but shall not exceed one hundred thousand dollars (\$100,000) per month, except as provided in paragraphs (2) and (3). In the event that the jurisdiction fails to pay fines imposed by the court in full and on time, the court may require the Controller to intercept any available state and local funds and direct such funds to the Building Homes and Jobs Trust Fund to correct the jurisdiction's failure to pay. The intercept of the funds by the Controller for this purpose shall not violate any provision of the California Constitution.

(2) If the jurisdiction has not complied with the order or judgment after three months following the imposition of fees described in paragraph (1), the court shall conduct a status conference. Following the status conference, if the court finds that the fees imposed pursuant to paragraph (1) are insufficient to bring the jurisdiction into compliance with the order or judgment, the court may multiply the fine determined pursuant to paragraph (1) by a factor of three. In the event that the jurisdiction fails to pay fines imposed by the court in full and on time, the court may require the Controller to intercept any available state and local funds and direct such funds to the Building Homes and Jobs Trust Fund to correct the jurisdiction's failure to pay. The intercept of the funds by the Controller for this purpose shall not violate any provision of the California Constitution.

(3) If the jurisdiction has not complied with the order or judgment six months following the imposition of fees described in paragraph (1), the court shall conduct a status conference. Upon a determination that the jurisdiction failed to comply with the order or judgment, the court may impose the following:

(A) If the court finds that the fees imposed pursuant to paragraphs (1) and (2) are insufficient to bring the jurisdiction into compliance with the order or judgment, the court may multiply the fine determined pursuant to paragraph (1) by a factor of six. In the event that the jurisdiction fails to pay fines imposed by the court in full and on time, the court may require the Controller to intercept any available state and local funds and direct such funds to the Building Homes and Jobs Trust Fund to correct the jurisdiction's failure to

pay. The intercept of the funds by the Controller for this purpose shall not violate any provision of the California Constitution.

(B) The court may order remedies available pursuant to Section 564 of the Code of Civil Procedure, under which the agent of the court may take all governmental actions necessary to bring the jurisdiction's housing element into substantial compliance pursuant to this article in order to remedy identified deficiencies. The court shall determine whether the housing element of the jurisdiction substantially complies with this article and, once the court makes that determination, it shall have the same force and effect, for all purposes, as the department's determination that the housing element substantially complies with this article. An agent appointed pursuant to this paragraph shall have expertise in planning in California.

(4) This subdivision does not limit a court's discretion to apply any and all remedies in an action or special proceeding for a violation of any law identified in subdivision (j).

(m) In determining the application of the remedies available under subdivision (l), the court shall consider whether there are any mitigating circumstances delaying the jurisdiction from coming into compliance with state housing law. The court may consider whether a city, county, or city and county is making a good faith effort to come into substantial compliance or is facing substantial undue hardships.

(n) Nothing in this section shall limit the authority of the office of the Attorney General to bring a suit to enforce state law in an independent capacity. The office of the Attorney General may seek all remedies available under law including those set forth in this section.

(o) Notwithstanding Sections 11040 and 11042, if the Attorney General declines to represent the department in any action or special proceeding brought pursuant to a notice or referral under subdivision (j), the department may appoint or contract with other counsel for purposes of representing the department in the action or special proceeding.

(p) Notwithstanding any other provision of law, the statute of limitations set forth in subdivision (a) of Section 338 of the Code of Civil Procedure shall apply to any action or special proceeding brought by the office of the Attorney General or pursuant to a notice or referral under subdivision (j), or by the department pursuant to subdivision (o).

(q) The amendments to this section made by the act adding this subdivision shall not be construed to limit the department's ability to enforce programmatic requirements or remedies against cities, counties, and continuums of care pursuant to the Homeless Housing, Assistance, and Prevention program (Chapter 6 (commencing with Section 50216) and Chapter 6.5 (commencing with Section 50230) of Part 1 of Division 31 of the Health and Safety Code), the Encampment Resolution Funding program (Chapter 7 (commencing with Section 50250) of Part 1 of Division 31 of the Health and Safety Code), and the Family Homelessness Challenge Grants and Technical Assistance Program (Chapter 8 (commencing with Section 50255) of Part 1 of Division 31 of the Health and Safety Code).

**SEC. 3.** *Section 65585.03 of the Government Code is amended to read:*

**65585.03.** A housing element or amendment shall be considered to be in substantial compliance with this article when the local agency adopts the housing element or amendment for the current planning period in accordance with Section 65585 and ~~either~~ *any* of the following apply:

(a) The department finds that the adopted housing element or amendment is in substantial compliance with this article and the department's compliance findings have not been superseded by subsequent contrary findings by the department or by a decision of a court of competent jurisdiction.

(b) A court of competent jurisdiction determines that the adopted housing element or amendment substantially complies with this article and the court's decision has not been overturned or superseded by a subsequent court decision or by statute.

*(c) A jurisdiction adopts a housing element pursuant to paragraph (3) of subdivision (f) of Section 65585, and the department had not issued contrary written findings within 30 days of receiving notice of the legislative body's resolution.*

**SECTION 1-SEC. 4.** Section 65589.10 is added to the Government Code, to read:

**65589.10.** (a) It is the intent of the Legislature to create incentives for jurisdictions that demonstrate exceptional housing production outcomes beyond compliance with housing element requirements and enactment of prohousing local policies. It is the intent of the Legislature that these incentives be in the form of enhanced funding benefits and regulatory relief from state housing mandates. It is the intent of the Legislature that, in adopting regulations related to housing leadership designation criteria, the department shall create production thresholds that consider the differing housing affordability challenges faced by jurisdictions across California and how those challenges may require different performance standards.

(b) A jurisdiction with a housing leadership designation pursuant to this section may do any of the following:

(1) Notwithstanding the requirements of Section 65852.21, establish by ordinance an exemption from the requirements of that section.

(2) Notwithstanding the requirements of Section 66411.7, establish by ordinance an exemption from, or modification of, any of the following:

(A) Minimum lot sizes established by paragraph (2) of subdivision (a) of Section 66411.7, provided that the jurisdiction continues to allow ministerial approval of at least two units on parcels that meet locally established criteria.

(B) Setback requirements, including front, side, and rear setbacks, established by paragraph (3) of subdivision (c) of Section 66411.7.

(C) Objective design review standard requirements, including building height, floor area ratio, and architectural requirements, established by paragraphs (1) and (2) of subdivision (c) of Section 66411.7.

(3) Notwithstanding clause (i) of subparagraph (A) of paragraph (2) of subdivision (b) of Section 65914.2, if the jurisdiction is a local agency that has received written communication from the Attorney General or the department advising that the local agency's decision, action, or inaction would represent a violation of a specific housing reform law, cure the violation within 90 days from the date of receipt of that communication before any fines may be imposed under Section 65914.2. If the jurisdiction cures the violation within the 90-day period, a fine shall not be imposed for that violation.

(4) Notwithstanding Section 65915, establish by ordinance height limitations as a waiver or reduction of development standards under subdivision (e) of Section 65915, provided that the jurisdiction continues to grant a minimum density bonus consistent with the requirements of subdivision (f) of Section 65915 for qualifying housing developments.

(c) (1) On or before July 1 of each year, the department shall do both of the following:

(A) Publish a list specifying the affordability designation for each jurisdiction that has submitted a complete annual progress report under subdivision (d) on its internet website for the applicable year.

(B) Publish a list of housing leadership designated jurisdictions on its internet website.

(2) The department shall not condition housing leadership designation on the receipt of any application or conditions not described in this section.

(3) The department shall report the designations pursuant to subparagraph (A) of paragraph (1) to the Office of Land Use and Climate Innovation, and, upon request, any other applicable agency or department, annually.

(d) To qualify for a housing leadership designation, a jurisdiction shall meet the following requirements:

(1) The jurisdiction has submitted a complete annual progress report for the preceding five years.

(2) The ~~jurisdiction meets the applicable of~~ *jurisdiction's housing production, calculated as permits issued per 1,000 residents net of demolition permits over the preceding five years, meets, as applicable,* the following conditions:

(A) For an affordable jurisdiction, the ~~jurisdiction has permitted an average of at least five housing units per 1,000 residents net of demolition permits issued each year over the preceding five years.~~ *jurisdiction's housing production is within the top 10 percent of jurisdictions designated as affordable jurisdictions.*

(B) For an unaffordable jurisdiction, the ~~jurisdiction has permitted an average of at least 7.5 housing units per 1,000 residents net of demolition permits issued each year over the preceding five years.~~ *jurisdiction's*

*housing production is within the top 5 percent of jurisdictions designated as unaffordable jurisdictions.*

(C) For an extremely unaffordable jurisdiction, the ~~jurisdiction has permitted an average of at least 10 housing units per 1,000 residents net of demolition permits issued each year over the preceding five years.~~ *jurisdiction's housing production is within the top 2.5 percent of jurisdictions designated as extremely unaffordable jurisdictions.*

(e) (1) On or before July 1, 2027, the department, in consultation with stakeholders, shall adopt emergency regulations to implement this section, including procedures for jurisdictions to apply for a housing leadership designation, methods for calculating and verifying production thresholds, and criteria for determining approval rates and approval timelines.

(2) Notwithstanding Section 11346.1, the emergency regulations adopted pursuant to this subdivision shall remain in effect until the date that permanent regulations to implement this section become effective.

(f) For purposes of this section:

(1) "Affordable jurisdiction" means a city, county, or a city and county where the ratio of the median purchase price of a home in the jurisdiction, as the numerator, to the area median household income, as the denominator, is less than five.

(2) "Area median household income" means the median family income for an area, as determined by the United States Department of Housing and Urban Development, with respect to the standard metropolitan statistical area. For a jurisdiction located outside a standard metropolitan statistical area, "median household income" means the countywide median household income.

(3) "Extremely unaffordable jurisdiction" means a city, county, or a city and county where the ratio of the median purchase price of a home in the jurisdiction, as the numerator, to the area median household income, as the denominator, is greater than 10.

(4) "Unaffordable jurisdiction" means a city, county, or a city and county where the ratio of the median purchase price of a home in the jurisdiction, as the numerator, to the area median household income, as the denominator, is greater than or equal to 5 but less than or equal to 10.

~~SEC. 2.~~**SEC. 5.** The Legislature finds and declares that the state faces a housing crisis of availability and affordability, in large part due to a severe shortage of housing, and solving the housing crisis therefore requires a multifaceted, statewide approach, which is a matter of statewide concern and is not a municipal affair as that term is used in Section 5 of Article XI of the California Constitution. Therefore, Section ~~1~~ 5 of this act adding Section 65589.10 to the Government Code applies to all cities, including charter cities.

# CITY COUNCIL AGENDA REPORT



**TO: MAYOR WRIGHT AND MEMBERS OF THE CITY COUNCIL**

**FROM: ERIC WIER, CITY MANAGER**

**BY: BOB BROWN, CONTRACT PLANNING DIRECTOR**

**DATE: APRIL 20, 2026**

**SUBJECT: OPC GRANT AWARD ACCEPTANCE FOR COASTAL RESILIENCY PLAN**

---

## **RECOMMENDATION**

- Hear staff report
- Technical questions from the Council
- Receive public comment
- Further Council discussion
- Approve and adopt Resolution No. 2026-32, A Resolution of the City Council of the City of Crescent City Accepting the Grant Award from the Ocean Protection Council for Development of Sea Level Rise Adaptation Plans in Compliance with SB 272RE OPC Grant application - Crescent City Coastal Resiliency Strategy

## **BACKGROUND**

On November 17, 2025, the City Council authorized City staff to submit a grant application to the Ocean Protection Council for Development of Sea Level Rise Adaptation Plans in Compliance with SB 272. On March 23, 2026, the Ocean Protection Council approved the City's grant submittal of \$320,911 for development of the Crescent City Coastal Resiliency Plan over a two-year period.

SB 272 (Laird 2023) requires local governments to create sea-level rise (SLR) plans based on the best available science which include (1) conducting Vulnerability Assessments of coastal hazards exacerbated by SLR; and (2) developing Adaptation Plans with recommended projects that could result in reduced coastal hazards. SB 272 requires the results of these two plans to be part of the Coastal Commission's approved City Local Coastal Program (LCP) before 2034. State funding for project implementation is currently available to jurisdictions that have completed this process.

## **ITEM ANALYSIS**

SHN, with the City, submitted a grant application to OPC for the City to address climate change resiliency, as is required by SB 272. Coastal Quest is under contract with OPC and has been providing the City with technical assistance for the OPC grant submission. The City of Crescent City proposed to develop a Coastal Resiliency Plan encompassing a SLR, Tsunami Hazards, and Erosion Vulnerability Assessment and Adaptation Plan. With approximately 3.5 miles of coastline, the City faces an exceptional combination of

coastal hazards – including tsunami inundation, storm surge, bluff erosion, and tidal flooding – that will be significantly exacerbated by SLR. The project will use best available science to assess vulnerabilities across the City’s coastal infrastructure, habitats, and community resources, and identify prioritized adaptation strategies and pathways through 2150. As part of the City’s efforts, the City will collaborate closely with the Tolowa Dee-ni’ Nation, which also was awarded SB 1 funding through the Tribal Cultural Resources solicitation to conduct a SLR assessment that includes tribal resources. This will ensure a comprehensive, complementary, and non-duplicative approach for sea level rise planning in this region.

The resulting Adaptation Plan will evaluate protection, accommodation, and retreat strategies with an emphasis on nature-based solutions, and establish adaptation pathways with clear triggers, a monitoring strategy, and a financing framework to guide future implementation. The project will culminate in an Administrative Draft LCP Policy and Implementation Document, including draft policy language and development standards that will position the City for a future LCP amendment and compliance with SB 272.

Through this proposed program, the City will:

- (1) Compile existing reports and research to determine the City’s vulnerability to coastal hazards (flooding, tsunami, wave runup and overtopping, tidal inundation, bluff erosion, etc.) as a result of SLR;
- (2) Identify vulnerable community resources, infrastructure, environmentally sensitive habitat areas, coastal access, and tribal cultural resources; and
- (3) Develop and prioritize resilient adaptation strategies, which, as noted above, would qualify for future funding as long as it is available.

Community engagement will be incorporated throughout the process, providing information, and listening to concerns, needs and suggestions on adaptation strategies. Existing conditions assessment, vulnerability assessment, and adaptation strategies related to SLR, flooding, tsunami hazards, and erosion will ultimately result in an update to the City’s local coastal program (LCP) to begin to address SB 272 requirements.

SHN is committed to engage in this Program in a manner that ensures that it is successfully completed within budget and time schedule. SHN has dedicated staff with necessary technical experience in Planning, Engineering, Geology, GIS public facilitation, etc. to provide guidance to help the City achieve its resiliency goals.

Some SLR scenarios to consider include:

- Increased sea levels will increase the elevation of storm surges. Highway 101 is already overtopped at South Beach. Further overtopping could occur at the S curves on Highway 101 adjacent to Elk Creek, closing roadways during extreme storm events.
- Initially, Highway 101 and the Lighthouse Cove RV Park may be affected by king tides 2-4 times/year, requiring closure of both during those times.

- Raised storm surges/wave cutting at the base of the unprotected western ocean bluffs may increase the vulnerability of the bluffs to recede with possible loss of sections of Pebble Beach Drive, as occurred in 2023.
- SLR could cause tidal influence further up the Elk Creek channel and change habitats in the Elk Creek wetlands east of Highway 101 into salt marsh or mudflats. Riparian vegetation would die back due to increased salt intrusion.
- SLR could cause tidal influence, combined with storm surges and stream flooding, to begin to inundate the eastern portion of the City by accessing the Elk Creek wetlands east of Highway 101. Increasing SLR will begin to inundate the eastern areas of the City and extend to both the north and west.
- Storm drain systems/culverts may back up and be less effective at discharging runoff, affecting drainage in the downtown area.
- Groundwater elevations may rise throughout the City, changing vegetation, drainage patterns and potentially ground stability.
- While the Wastewater Treatment Facility (WWTF) is above current projections of SLR, the collection system may be surcharged by tidal influence and increased groundwater levels, resulting in increased Inflow and Infiltration (I/I) to the WWTF plant.

### **FISCAL ANALYSIS**

There is no direct fiscal impact on the City. There is no match proposed/required for this grant and, while there are funds available to City staff to support this Project, SHN will be responsible for completion of this Project.

### **STRATEGIC PLAN ANALYSIS**

This action supports the following Strategic Plan Goals:

GOAL 1: SUPPORT QUALITY SERVICES, COMMUNITY SAFETY, AND HEALTH TO ENHANCE THE QUALITY OF LIFE AND EXPERIENCE OF OUR RESIDENTS AND VISITORS

(A) Enhance collaboration with other agencies and the community to better aid the public

(B) Ensure that information shared between departments, with other agencies, and with the public is both accurate and timely.

(C) Empower and utilize Police, Fire, and Public Works departments to make Crescent City one of the safest cities in the United States.

GOAL 2: PROMOTE A THRIVING LOCAL ECONOMY

(D) Collaborate with other jurisdictions and non-profits to maximize regional effectiveness and amplify funding opportunities.

(F) Plan and prepare for the growth and future needs of the Crescent City community by: Expanding on the success of grant funding by maximizing utilization of opportunities with corresponding community needs.

**ATTACHMENTS**

1. Draft Resolution No. 2026-32





# CITY COUNCIL AGENDA REPORT

**TO: MAYOR WRIGHT AND MEMBERS OF THE CITY COUNCIL**

**FROM: ERIC WIER, CITY MANAGER**

**BY: RICHARD GRIFFIN, CHIEF OF POLICE  
MARTHA D. RICE, CITY ATTORNEY**

**DATE: APRIL 20, 2026**

**SUBJECT: MILITARY EQUIPMENT USE POLICY**

---

## **RECOMMENDATION**

- Hear staff report
- Technical questions from the Council
- Receive public comment
- Further Council discussion
- Receive the Military Equipment Use 2025 Annual Report
- Waive full reading, read by title only and introduce Ordinance No. 864, An Ordinance of the City Council of the City of Crescent City Confirming Approval of the CCPD Military Equipment Use Policy

## **BACKGROUND**

Assembly Bill 481 (AB 481), codified at Government Code sections 7070 through 7075 requires a law enforcement agency (LEA) to obtain approval from the applicable governing body, via adoption of a “military equipment” use policy (the Policy) by ordinance (the Ordinance), prior to the LEA funding, acquiring, or using military equipment. The term “military equipment” includes a variety of law enforcement tools (including less than lethal weapons) that are a component of overall best practices for law enforcement agencies throughout the country. Items deemed to be “military equipment” include, but are not limited to, unmanned aerial or ground vehicles, armored vehicles, command and control vehicles, pepper balls, less lethal shotguns, less lethal 40mm projectile launchers, long range acoustic devices, and flashbangs. Many of these tools are vital to protecting the safety of citizens and officers as they provide peace officers with the ability to safely resolve volatile situations which otherwise might rise to the level of a lethal force encounter.

A military equipment use policy must address the following matters for each type of military equipment:

- (1) description, quantity, capabilities, lifespan, and manufacturer product descriptions;
- (2) the purposes and authorized uses for each type of military equipment;
- (3) fiscal impact including the initial costs of obtaining the equipment and annual costs of maintenance;
- (4) the legal and procedural rules that govern each authorized use; and
- (5) the training, including any course required by POST, that must be completed before an officer may use each specific type of military equipment.

The policy must also detail the mechanisms to ensure compliance with the policy, including which persons or entities have oversight authority, and, if applicable, what legally enforceable sanctions are put in place for violations of the policy. The policy must also provide procedures by which members of the public may register complaints or concerns or submit questions about the use of each specific type of military equipment, and how the department will ensure that each complaint, concern, or question receives a timely response.

AB 481 also requires an annual report (based on the previous calendar year) detailing the use, costs, and inventory of each type of military equipment listed in the policy as well as the result of any audits and a summary of complaints concerning the military equipment. After submission of the report, the City is required to hold one well-publicized public meeting where the public is invited to ask questions concerning the policy.

Prior to re-authorizing the policy, the City Council must determine that the identified military equipment was used in compliance with the policy.

### **ITEM ANALYSIS**

The Military Equipment Use Policy 2025 Annual report is attached hereto. The specific equipment identified in the policy was utilized for training purposes, and one officer involved shooting incident in calendar year 2025. The ordinance will simply confirm the Council's approval of the policy, which is necessary to be able to use or purchase the equipment.

#### **Timeline:**

- |                         |          |
|-------------------------|----------|
| • Receive Annual Report | April 20 |
| • Introduce Ordinance   | April 20 |
| • Public Meeting        | May 18   |
| • Adopt Ordinance       | June 1   |
| • Effective Date        | July 1   |

## **FISCAL ANALYSIS**

The recommended actions will have no direct fiscal impact other than ordinance publication costs.

## **STRATEGIC PLAN ASSESSMENT**

This action supports the following Strategic Plan goals and objectives:

GOAL 1: Support quality services, community safety, and health to enhance the quality

- A. Empower and utilize Police, Fire, and Public Works departments to make Crescent City one of the safest cities in the United States

GOAL 3: Obtain the highest levels of organizational excellence

- A. Develop a results-based organization which utilizes community involvement, innovation, transparency, and leadership

## **ATTACHMENTS**

1. Military Equipment Use Policy 2025 Annual Report
2. Draft Ordinance No. 864 (Military Equipment Use Policy)



# CRESCENT CITY POLICE DEPARTMENT MILITARY EQUIPMENT USE POLICY 2025 ANNUAL REPORT

## 1. PURPOSE

The purpose of this report is to provide the City Council and the public with information on the use of equipment authorized under the Department’s approved Military Equipment Use Policy for the 2025 calendar year as required by Government Code § 7072. Additional information can be found on the department website or by calling and scheduling a telephone appointment with the military equipment coordinator.

Department website: <https://www.crescentcity.org/departments/Police>

AB 481 Military Equipment Transparency

Department telephone number:

1-707-464-2133

## 2. CALENDAR YEAR 2025 EQUIPMENT USE & COST

Type of Equipment	2025 Use/ Purpose	2025 Cost / Source of Funds	Inventory	2026 New Purchases	2026 Cost / Source of Funds
<b>CARBINE RIFLES AND AMMUNITION</b>					
Colt AR-15/M4	Training/Duty	\$0	4	None	\$500 – 1,000 parts (if needed) General Fund
Daniel Defense MK18	Training/Duty	\$0	6	0	\$500 – 1,000 parts (if needed) General Fund
5.56 mm/ .223 Remington	Training/Duty	\$4,817 General Fund	30,660	\$0-\$5,000	\$0 -- 5,000 General Fund
Daniel Defense .308 caliber rifle (actual models under evaluation)	Training/Duty	\$0	0	2-4	\$4000-\$8000 General Fund
<b>TEAR GAS</b>					
40MM Direct Impact OC	None	\$ 0	10	0-20	\$ 0-2000 General Fund
40MM Direct Impact CS	None	\$ 0	10	0-20	\$0-2000 General Fund
40MM Powder Barricade Round OC	None	\$ 0	0	0-20	\$0-2000 General Fund

40 MM Ferret Liquid Barricade Penetrator Round CS	None	\$ 0	0	0-20	\$0-2,000 General Fund
--	------	------	---	------	---------------------------

Type of Equipment	2025 Use/ Purpose	2025 Cost / Source of Funds	Inventory	2026 New Purchases	2026 Cost / Source of Funds
<b>PEPPERBALL LAUNCHER</b>					
Mission TPR Pepper Ball Gun	Training/Patrol	\$0	1	3	\$1,000-1,500 General Fund
PepperBall Live SD Projectiles	Training/Patrol	\$0 General Fund	250 rounds	500 rounds	\$5,00-1,000 General Fund
<b>PROJECTILE LAUNCH PLATFORMS AND ASSOCIATED MUNITIONS</b>					
Remington Less- Lethal Shotgun	Training/Patrol	\$0	10	None	\$500-1,000 General Fund
CTS Model 2581 Super Sock Bean Bag 12 ga round	Training, Patrol	\$0	95 rounds	50 rounds	\$0-500 General Fund
<b>UNMANNED, REMOTELY PILOTED, POWERED AERIAL DRONE</b>					
None	None	None	None	None	None

### 3. ADDITIONAL REPORTING

- 3.1 No complaints were received in calendar year 2025 regarding the use of equipment authorized by the Military Equipment Use Policy.
- 3.2 One internal audit was conducted in calendar year 2025 regarding the use of equipment authorized by the Military Equipment Use Policy.
- 3.3 No Military Equipment Use Policy violations were identified or reported in calendar year 2025.

### 4. COMMUNITY ENGAGEMENT

Within 30 days of submitting and publicly releasing this annual report, the City must hold at least one well-publicized and conveniently located community engagement meeting, at which the department should discuss the report and respond to public questions regarding the funding, acquisition, or use of military equipment.

\*\*\*END REPORT\*\*\*

**ORDINANCE NO. 864**

**AN ORDINANCE OF THE CITY COUNCIL OF THE CITY OF CRESCENT CITY  
APPROVING THE CCPD MILITARY EQUIPMENT USE POLICY**

**WHEREAS**, the City of Crescent City is a general law city incorporated under the laws of State of California in 1854; and

**WHEREAS**, Assembly Bill 481, signed by the Governor on September 30, 2021, requires the governing bodies of local law enforcement agencies to adopt a military equipment use policy by ordinance; and

**WHEREAS**, Assembly Bill 481 requires that the governing body commence this process prior to May 1, 2022; and

**WHEREAS**, the policy must be reviewed and reauthorized on an annual basis following receipt of a report on the use of military equipment by the law enforcement agency; and

**WHEREAS**, the purpose of the policy is to provide transparency regarding the law enforcement agency's use of "military equipment"; and

**WHEREAS**, the City Council initially approved the Military Equipment Use Policy on June 6, 2022 by way of Ordinance No. 830; and

**WHEREAS**, the City Council has approved and amended the Military Equipment Use Policy on at least an annual basis with the last approval being on June 16, 2025 with Ordinance No. 856; and

**WHEREAS**, the Chief of Police has presented the Military Equipment Use 2025 Annual Report to the City Council and posted the report on its webpage; and

**WHEREAS**, on \_\_\_\_\_, 2026 the City held a well-publicized public meeting where questions and concerns regarding the policy or the equipment authorized thereunder could be heard and addressed by the Chief of Police and the City Council.

**NOW, THEREFORE, the City Council of the City of Crescent City, State of California, hereby ordains:**

**SECTION 1. RECITALS.** The City Council finds the above recitals to be true and correct and are incorporated herein as if set forth in full.

**SECTION 2. UNCODIFIED ORDINANCE.** This ordinance is an uncodified ordinance of the City of Crescent City.

**SECTION 3. FINDINGS.** The City Council makes the following findings and determinations:

- a. The military equipment described in Crescent City Police Department Policy 710 attached hereto is necessary because there is no reasonable alternative that can achieve the same objective of officer and civilian safety.
- b. Crescent City Police Department Policy 710 will safeguard the public's welfare, safety, civil rights, and civil liberties.

- c. The military equipment identified in Crescent City Police Department Policy 710 is reasonably cost effective compared to available alternatives that can achieve the same objective of officer and civilian safety.

**SECTION 4. APPROVAL OF POLICY.** The Crescent City Police Department Policy 710: Military Equipment attached hereto and made a part hereof by this reference, is hereby confirmed as approved by the City Council.

**SECTION 5. SEVERABILITY.** If any part of this Ordinance is held to be invalid or inapplicable to any situation by a court of competent jurisdiction, such decision will not affect the validity of the remaining portions of this Ordinance or the applicability of this Ordinance to other situations.

**SECTION 6. CEQA FINDINGS.** This Ordinance has been reviewed for compliance with the California Environmental Quality Act (CEQA), and the CEQA Guidelines, and has been found to be exempt pursuant to Section 15061(b)(3) (general rule) of the CEQA Guidelines, because the City Council hereby finds with certainty that there is no possibility the passage of this Ordinance will have a significant effect on the environment.

**SECTION 7. EFFECTIVE DATE & PUBLICATION.** This Ordinance will become effective 30 days after the date of its adoption. The City Clerk shall cause this ordinance to be published within 15 days of its adoption in accordance with the requirements of Government Code Section 36933.

**INTRODUCED** at a meeting of the City Council of the City of Crescent City held on \_\_\_\_\_, 2026.

**PASSED AND ADOPTED** by the City Council of the City of Crescent City at a regular meeting of the City Council held this \_\_\_\_ day of \_\_\_\_\_ 2026 by the following polled vote:

- AYES:
- NOES:
- ABSENT:
- ABSTAIN:

\_\_\_\_\_  
Isaiah Wright, Mayor

ATTEST:

\_\_\_\_\_  
Robin Altman, City Clerk

APPROVED AS TO FORM:

\_\_\_\_\_  
Martha D. Rice, City Attorney

# Military Equipment

## 710.1 PURPOSE AND SCOPE

The purpose of this policy is to provide guidelines for the approval, acquisition, and reporting requirements of military equipment (Government Code § 7070; Government Code § 7071; Government Code § 7072). Government Code 7070(d)(7) requires that this policy have procedures by which members of the public may register complaints, or concerns or submit questions about the use of military equipment. This information can be found on the department website or by calling and scheduling a telephone appointment with the military equipment coordinator.

Department website: <https://www.crescentcity.org/departments/Police>

AB 481 Military Equipment Transparency

Department telephone number:

1-707-464-2133

### 710.1.1 DEFINITIONS

Definitions related to this policy include (Government Code § 7070):

**Governing body** – The elected or appointed body that oversees the Department.

**Military equipment** – Includes but is not limited to the following:

- Unmanned, remotely piloted, powered aerial or ground vehicles.
- Mine-resistant ambush-protected (MRAP) vehicles or armored personnel carriers.
- High mobility multipurpose wheeled vehicles (HMMWV), two-and-one-half-ton trucks, five-ton trucks, or wheeled vehicles that have a breaching or entry apparatus attached.
- Tracked armored vehicles that provide ballistic protection to their occupants.
- Command and control vehicles that are either built or modified to facilitate the operational control and direction of public safety units.
- Weaponized aircraft, vessels, or vehicles of any kind.
- Battering rams, slugs, and breaching apparatuses that are explosive in nature. This does not include a handheld, one-person ram.
- Firearms and ammunition of .50 caliber or greater, excluding standard-issue shotguns and standard-issue shotgun ammunition.
- Specialized firearms and ammunition of less than .50 caliber, including firearms and accessories identified as assault weapons in Penal Code § 30510 and Penal Code § 30515, with the exception of standard-issue firearms.
- Any firearm or firearm accessory that is designed to launch explosive projectiles.
- Noise-flash diversionary devices and explosive breaching tools.

# Crescent City Police Department

Crescent City Police Department Manual

## *Military Equipment*

---

- Munitions containing tear gas or OC, excluding standard, service-issued handheld pepper spray.
- Area denial electroshock devices, microwave weapons, water cannons, long-range acoustic devices (LRADs), acoustic hailing devices, and sound cannons.
- Kinetic energy weapons and munitions.
- Any other equipment as determined by a governing body or a state agency to require additional oversight.

### **710.2 POLICY**

It is the policy of the Crescent City Police Department that members of this department comply with the provisions of Government Code § 7071 with respect to military equipment.

### **710.3 MILITARY EQUIPMENT COORDINATOR**

The Chief of Police should designate a member of this department to act as the military equipment coordinator. The responsibilities of the military equipment coordinator include but are not limited to:

- (a) Acting as liaison to the governing body for matters related to the requirements of this policy.
- (b) Identifying department equipment that qualifies as military equipment in the current possession of the department, or the equipment the department intends to acquire that requires approval by the governing body.
- (c) Conducting an inventory of all military equipment at least annually.
- (d) Collaborating with any allied agency that may use military equipment within the jurisdiction of Crescent City Police Department (Government Code § 7071).
- (e) Preparing for, scheduling, and coordinating the annual community engagement meeting to include:
  1. Publicizing the details of the meeting.
  2. Preparing for public questions regarding the department's funding, acquisition, and use of equipment.
- (f) Preparing the annual military equipment report for submission to the Chief of Police and ensuring that the report is made available on the department website (Government Code § 7072).
- (g) Establishing the procedure for a person to register a complaint or concern, or how that person may submit a question about the use of a type of military equipment, and how the department will respond in a timely manner.

### **710.4 MILITARY EQUIPMENT INVENTORY**

The following constitutes a list of qualifying equipment for the department:

- (a) Specialized Firearms and Ammunition (Category 9)
- (a) Description, quantity, capabilities, and purchase cost:

# Crescent City Police Department

Crescent City Police Department Manual

## *Military Equipment*

---

- The Carbine Rifle is a firearm, capable of accurately stopping an armed subject at various distances. The Carbine Rifle is a lightweight, air-cooled, gas operated, magazine fed, shoulder fired weapon, designed for semiautomatic or selective fire. The Carbine Rifle does not have an expiration and will need to be serviced or replaced when the Rifle fails or breaks. The .223/5.56 cartridge, .308/7.62 cartridge, and the .300 blackout cartridge is used as a lethal option designed to stop violent encounters. The projectile is capable of penetrating soft body armor being worn by armed subjects.
- Colt AR-15/M4 cost: \$1,200, quantity: 4, Caliber 5.56MM. Daniel Defense MK18 cost \$2,000, quantity 6, caliber 5.56.
- Authorized Make/Model of rifles for individual officer purchase:
  - .223/5.56 caliber: Daniel Defense - DDM4®V7®, DDM4®V7® PRO GUN METAL GRAY, MK18, M4A1, MK12, DDM4®V7® PRO, DDM4®V9®, DDM4®V7®SLW, DDM4ISR®, DDM4®V4®S, DDM4®V7®S, DDM4 V5S, or similar models approved by Chief of Police.
  - .300 blackout caliber: Daniel Defense - DDM4® PDW SBR or similar models approved by the Chief of Police.
  - .308/7.62 caliber: DPMS - AR-10.308 CALIBER RIFLE, MODEL LR-308, Daniel Defense -DD5®V3® (7.62 X 51MM), DD5®V4® (7.62 X 51MM), or similar models approved by the Chief of Police.
- The Winchester 5.56mm 55 grain full metal jacket is the primary duty cartridge deployed during potential lethal encounters. Cost: \$2,500 to \$3,000 annually, quantity: 3,000-5,000 rounds annually.
- Other brands and calibers also purchased, depending upon market supply/availability:
  - PMC 223A, .223 Remington 55 grain FMJ-BT
  - Federal XM193X 55-grain FMJ 5.56x45mm
  - Similar ammunition as approved by the Chief of Police based on market supply/availability.
- .308/7.62 and .300 blackout ammunition would be utilized in individual officer owned rifles and purchased by the officers. This ammunition would be subject to approval of existing CCPD policy.

(b) Purpose: To be used as a precision weapon to address a threat with more precision and/or greater distances than a handgun if present, safe, and feasible.

(c) Authorized Use: Only officers that are POST certified and authorized to use a rifle. All other applicable CCPD policies remain in effect, to include, but not limited to, CCPD Policy 301 Use of Force, and CCPD Policy 314 Firearms.

(d) Expected Lifespan: No expiration for Carbine Rifles or ammunition.

(e) Fiscal Impact: Carbine Rifle- Annual cost \$2,500 and \$5,000. New rifle purchase in 2026 expected between \$4000 to \$8,000. Rifle Ammunition \$2,500-\$5,000 annually.

## 2. Tear Gas (Category 12)

# Crescent City Police Department

Crescent City Police Department Manual

## *Military Equipment*

---

(a) Description, quantity, capabilities, and purchase cost: Chemical agent munition, which are commonly referred to as "tear gas," are used by the Crescent City Police Department as a non-lethal tool to disperse rioting suspects and on barricaded suspects. The Crescent City Police Department uses chemical agents which are used by law enforcement across the United States: CS (2-Chlorobenzylidenemalononitrile) and OC (Oleoresin Capsicum) CS is an irritating agent and lachrymator (irritates the eyes and causes tears to flow) CS has been medically tested in the UK and US, specifically by the U.S. Army. There are no known allergic reactions to CS. OC was de-regulated in California in 1996, is endorsed by the FBI, and is available to civilians to legally possess (2.5 oz or less). OC is an inflammatory agent which causes involuntary closure of eyes (open in 2-5 minutes) and respiratory inflammation (subsides in approximately 2 minutes).

- DEFENSE TECHNOLOGY, 40MM DIRECT IMPACT OC, #6320, cost: \$35, quantity: 20.

The 40mm Direct Impact® munition is a point-of-aim, point-of-impact direct-fire round. An excellent solution whether you need to incapacitate a single subject or control a crowd. When loaded with OC powder, the Direct Impact combines blunt trauma with the effects of an irritant powder, maximizing the potential for incapacitation. The 40mm Direct Impact® munition travels at an average velocity of 305 feet per second (89.9 mps) with an effective range of 5 ft – 120 ft (1.52m – 36.6m). This lightweight, high-speed projectile consists of a plastic body and a crushable foam nose. The orange foam nose indicates that the round contains an OC powder payload. This munition is a point-of-aim, point-of-impact direct fire round which has passed extensive human effects assessments for blunt impact and penetration.

- DEFENSE TECHNOLOGY, 40MM DIRECT IMPACT CS, #6322, cost: \$35, quantity: 20.

The 40mm Direct Impact® munition is a point-of-aim, point-of-impact direct-fire round. An excellent solution whether you need to incapacitate a single subject or control a crowd. When loaded with CS powder, the Direct Impact combines blunt trauma with the effects of an irritant powder, maximizing the potential for incapacitation.

The 40mm Direct Impact® munition travels at an average velocity of 295 feet per second (89.9 mps) with an effective range of 5 ft – 120 ft (1.52m – 36.6m). This lightweight, high-speed projectile consists of a plastic body and a crushable foam nose. The blue foam nose indicates that the round contains a CS powder payload. This munition is a point-of-aim, point-of-impact direct fire round which has passed extensive human effects assessments for blunt impact and penetration. The 40 mm Direct Impact Round is most commonly used by tactical teams in situations where greater accuracy and deliverable energy is desired for the incapacitation of an aggressive, non-compliant subject at longer distances.

- DEFENSE TECHNOLOGY, 40MM POWDER BARRICADE ROUND, OC, #2290, cost: \$35, quantity: 20.

The Ferret® 40 mm Barricade Penetrating Round is filled with an OC powder chemical agent.

It is a frangible projectile that is spin stabilized utilizing barrel rifling. It is non-burning and

# Crescent City Police Department

Crescent City Police Department Manual

## *Military Equipment*

---

designed to penetrate barriers. Primarily used to dislodge barricaded subjects, it can also be used for area denial. Primarily used by tactical teams, it is designed to penetrate barriers, such as windows, hollow core doors, wallboard and thin plywood. Upon impact the nose ruptures and instantaneously delivers the agent payload inside a structure or vehicle. Effective range of 50 meters.

- DEFENSE TECHNOLOGY, FERRETT 40MM LIQUID BARRICADE PENETRATOR ROUND CS, #2262, cost: \$30, quantity: 20.

A less lethal 40MM round used to penetrate barriers, such as windows, hollow core doors, wallboard and thin plywood. Upon impacting the barrier, the nose cone ruptures and instantaneously delivers a small chemical payload inside of a structure or vehicle. In a tactical deployment situation, the 40mm Ferret is primarily used to dislodge barricaded subjects from confined areas. Its purpose is to minimize the risks to all parties through pain compliance, temporary discomfort and/or incapacitation of potentially violent or dangerous subjects. Effective range of 50 meters.

(b) Purpose: To limit the escalation of conflict where employment of lethal force is prohibited or undesirable. Situation for use of the less lethal weapon systems may include but are not limited to:

- Self-destructive, dangerous and/or combative individuals.
  - Training exercises or approved demonstrations.
  - Potentially vicious animals.
  - Circumstances where a tactical advantage can be obtained.
  - Riot/Crowd control and civil unrest incidents.

(c) Authorized Use: Only officers who have received POST certification in the use of chemical agents are authorized to use chemical agents. All other applicable CCPD policies remain in effect to include, but not limited to CCPD Policy 301- Use of Force, CCPD Policy 309- Control Devices and Techniques.

(d) Expected Lifespan:

- DEFENSE TECHNOLOGY, 40MM DIRECT IMPACT OC, #6320 – 5 years. DEFENSE TECHNOLOGY, 40MM DIRECT IMPACT CS, #6322, – 5 years.
- DEFENSE TECHNOLOGY, 40MM POWDER BARRICADE ROUND, OC, #2290, – 5 years.
- DEFENSE TECHNOLOGY, FERRETT 40MM LIQUID BARRICADE PENETRATOR ROUND CS, #2262 – 5 years.

(e) Fiscal Impact: Total allocated budget \$1,000-\$2,000 annually.

### 3. PepperBall Launcher (Category 12)

(a) Description, quantity, capabilities, and purchase cost:

- FTC Launcher System that uses high pressure air to deliver PAVA powder projectiles (similar to a paint ball delivery system). System capable of launching projectiles

# Crescent City Police Department

Crescent City Police Department Manual

## *Military Equipment*

---

at a subject up to 150'. Non-lethal option to offer law enforcement officers to deliver chemical agents and kinetic energy impacts to subjects in a potentially violent encounter. This is a de-escalation tool used to avoid further injuries or lethal options to a subject. Cost \$500, quantity: 4.

- MISSION TPR ORANGE PEPPER BALL GUN. target accurate up to 60Ft, Area Saturation to 0-175ft. Semi-Automatic 8 rd. magazine, deploys at 300ft. per second. Cost \$350-\$400. Quantity: 6.
- PepperBall Live SD Projectiles,.68 Caliber PAVA Powder. This projectile is best for direct impact or area saturation. Discharged from a PepperBall launcher, the projectile has a velocity of 280-425 FPS. The projectile has a direct impact of 60 ft and an area saturation of 150+ft. The projectile contains 2.0% PAVA powder. Cost: \$250 per 90 rounds

(b) Purpose: To limit the escalation of conflict where employment of lethal force is prohibited or undesirable. Situations for use of the less lethal weapon systems may include, but are not limited to:

- Self-destructive, dangerous and/or combative individuals.
- Riot/Crowd control and civil unrest incidents.
- Circumstances where a tactical advantage can be obtained.
- Potentially vicious animals.
- Training exercises or approved demonstrations.

(c) Authorized Use: Only those officers who have been trained in the use of the PepperBall launchers are authorized to use the PepperBall launchers. All other applicable CCPD policies remain in effect to include, but not limited to CCPD Policy 301- Use of Force, CCPD Policy 309- Control Devices and Techniques.

(d) Expected Lifespan:

- PepperBall Launcher: No Expiration
- Mission TPR Launcher: No expiration
- LIVE-SD Projectile: 1 year

(e) Fiscal Impact:

- PepperBall FTS Launcher: No fiscal impact or recurring cost
- Live SD Projectile: Approximately \$0 - \$1,000 annually
- Mission TPR Launcher: \$0 to \$400 annually

#### 4. Projectile Launch Platforms and Associated munitions (Category 14)

(a) Description, quantity, capabilities, and purchase cost:

PENN ARMS PGL-65 40 PUMP MULTI-LAUNCHER 5" CYL. FIXED STOCK W/ COMBO RAIL.

# Crescent City Police Department

Crescent City Police Department Manual

## *Military Equipment*

---

A 40mm pump-action advance magazine drum launcher with a fixed stock and combo rail. It has a six-shot capacity and rifled barrel. The features include: Double-action trigger, trigger lock push button and hammer lock safeties. It will fire standard 40mm less lethal ammunition, up to 5 inches in cartridge length. It will launch a 40MM less lethal round and is only authorized to be used by trained personnel.

- Remington 870 12 ga Less-Lethal Shotgun: Cost \$500-\$650, quantity 6
- DEFENSE TECHNOLOGY, 40MM DIRECT IMPACT OC, #6320, cost: \$35, quantity: 20.
- DEFENSE TECHNOLOGY, 40MM DIRECT IMPACT CS, #6322, cost: \$35, quantity: 20.
- DEFENSE TECHNOLOGY, 40MM POWDER BARRICADE ROUND, OC, #2290, cost: \$35, quantity: 20.
- DEFENSE TECHNOLOGY, FERRETT 40MM LIQUID BARRICADE PENETRATOR ROUND CS, #2262, cost: \$30, quantity: 20.
- CTS Model 2581 Super Sock Bean Bag 12 ga round - Cost \$6 a round, quantity 50-100 annually

(b) Purpose: To limit the escalation of conflict where employment of lethal force is prohibited or undesirable.

(c) Authorized Use: Situations for use of the less lethal weapon system may include, but not limited to:

- ◦ Self-destructive, dangerous and/or combative individuals.
- ◦ Riot/Crowd control and civil unrest incidents.
- ◦ Circumstances where a tactical advantage can be obtained.
- ◦ Potentially vicious animals.
- ◦ Training exercised or approved demonstrations.

All other applicable CCPD policies remain in effect, to include, but not limited to, CCPD Policy 301- Use of Force, CCPD Policy 309- Control Devices and Techniques.

(d) Expected Lifespan:

- 40 mm Launcher- No expiration
- Remington 870 Bean Bag Less Lethal shotgun- No expiration
- DEFENSE TECHNOLOGY, 40MM DIRECT IMPACT OC, #6320 – 5 years.
- DEFENSE TECHNOLOGY, 40MM DIRECT IMPACT CS, #6322, – 5 years.
- DEFENSE TECHNOLOGY, 40MM POWDER BARRICADE ROUND, OC, #2290, – 5 years.
- DEFENSE TECHNOLOGY, FERRETT 40MM LIQUID BARRICADE PENETRATOR ROUND CS, #2262 – 5 years.

# Crescent City Police Department

Crescent City Police Department Manual

## *Military Equipment*

---

- CTS Model 2581 Super Sock- 5 years

(e) Fiscal Impact:

- 40mm Launcher, estimated between \$0 - \$1000 annually
- Remington 870 less lethal shotgun, estimated between \$0 - \$1000 annually.
- DEFENSE TECHNOLOGY, 40MM DIRECT IMPACT OC, #6320, \$0 - \$250 annually
- DEFENSE TECHNOLOGY, 40MM DIRECT IMPACT CS, #6322, \$0 - \$250 annually
- DEFENSE TECHNOLOGY, 40MM POWDER BARRICADE ROUND, OC, \$0 - \$250 annually
- DEFENSE TECHNOLOGY, FERRETT 40MM LIQUID BARRICADE PENETRATOR ROUND CS, \$0 - \$250 annually
- CTS Model 2581, estimated between \$0 - \$500 annually

### **710.5 APPROVAL**

The Chief of Police or the authorized designee shall obtain approval from the governing body by way of an ordinance adopting the military equipment policy. As part of the approval process, the Chief of Police or the authorized designee shall ensure the proposed military equipment policy is submitted to the governing body and is available on the department website at least 30 days prior to any public hearing concerning the military equipment at issue (Government Code § 7071). The military equipment policy must be approved by the governing body prior to engaging in any of the following (Government Code § 7071):

- (a) Requesting military equipment made available pursuant to 10 USC § 2576a.
- (b) Seeking funds for military equipment, including but not limited to applying for a grant, soliciting or accepting private, local, state, or federal funds, in-kind donations, or other donations or transfers.
- (c) Acquiring military equipment either permanently or temporarily, including by borrowing or leasing.
- (d) Collaborating with another law enforcement agency in the deployment or other use of military equipment within the jurisdiction of this Crescent City Police Department.
- (e) Using any new or existing military equipment for a purpose, in a manner, or by a person not previously approved by the governing body.
- (f) Soliciting or responding to a proposal for, or entering into an agreement with, any other person or entity to seek funds for, apply to receive, acquire, use, or collaborate in the use of military equipment.
- (g) Acquiring military equipment through any means not provided above.

### **710.6 COORDINATION WITH OTHER JURISDICTIONS**

Military equipment being used in this jurisdiction by members of the Crescent City Police Department shall comply with the City of Crescent City's approved military equipment policy.

# Crescent City Police Department

Crescent City Police Department Manual

## *Military Equipment*

---

During times of mutual aid or when utilizing a Regional SWAT Team, allied agencies and their personnel should only use military equipment which is approved for use in the allied agencies' own military equipment policy. This shall not prevent Crescent City Police Officers who may become members of a Regional SWAT Team from deploying military equipment approved by the Regional SWAT Team for use by Crescent City Police Officers who are assigned to the SWAT Team. Nothing in this policy shall prohibit the use of unapproved military equipment by members of the Crescent City Police Department or its allied agencies during times of exigent circumstances.

### **710.7 ANNUAL REPORT**

Upon approval of a military equipment policy, the Chief of Police or the authorized designee should submit a military equipment report to the governing body for each type of military equipment approved within one year of approval, and annually thereafter for as long as the military equipment is available for use (Government Code § 7072).

The Chief of Police or the authorized designee should also make each annual military equipment report publicly available on the department website for as long as the military equipment is available for use. The report shall include all information required by Government Code § 7072 for the preceding calendar year for each type of military equipment in department inventory.

### **710.8 COMMUNITY ENGAGEMENT**

Within 30 days of submitting and publicly releasing the annual report, the department shall hold at least one well-publicized and conveniently located community engagement meeting, at which the department should discuss the report and respond to public questions regarding the funding, acquisition, or use of military equipment.