

CITY OF DERBY

Plans For
LOCAL TRANSPORTATION CAPITAL IMPROVEMENT PROGRAM
STATE PROJECT NUMBER L036-0002

DIVISION STREET & SEYMOUR AVENUE SAFETY IMPROVEMENTS PUBLIC INFORMATION MEETING

City of
DERBY
 THE HONORABLE
JOSEPH L. DiMARTINO
 MAYOR

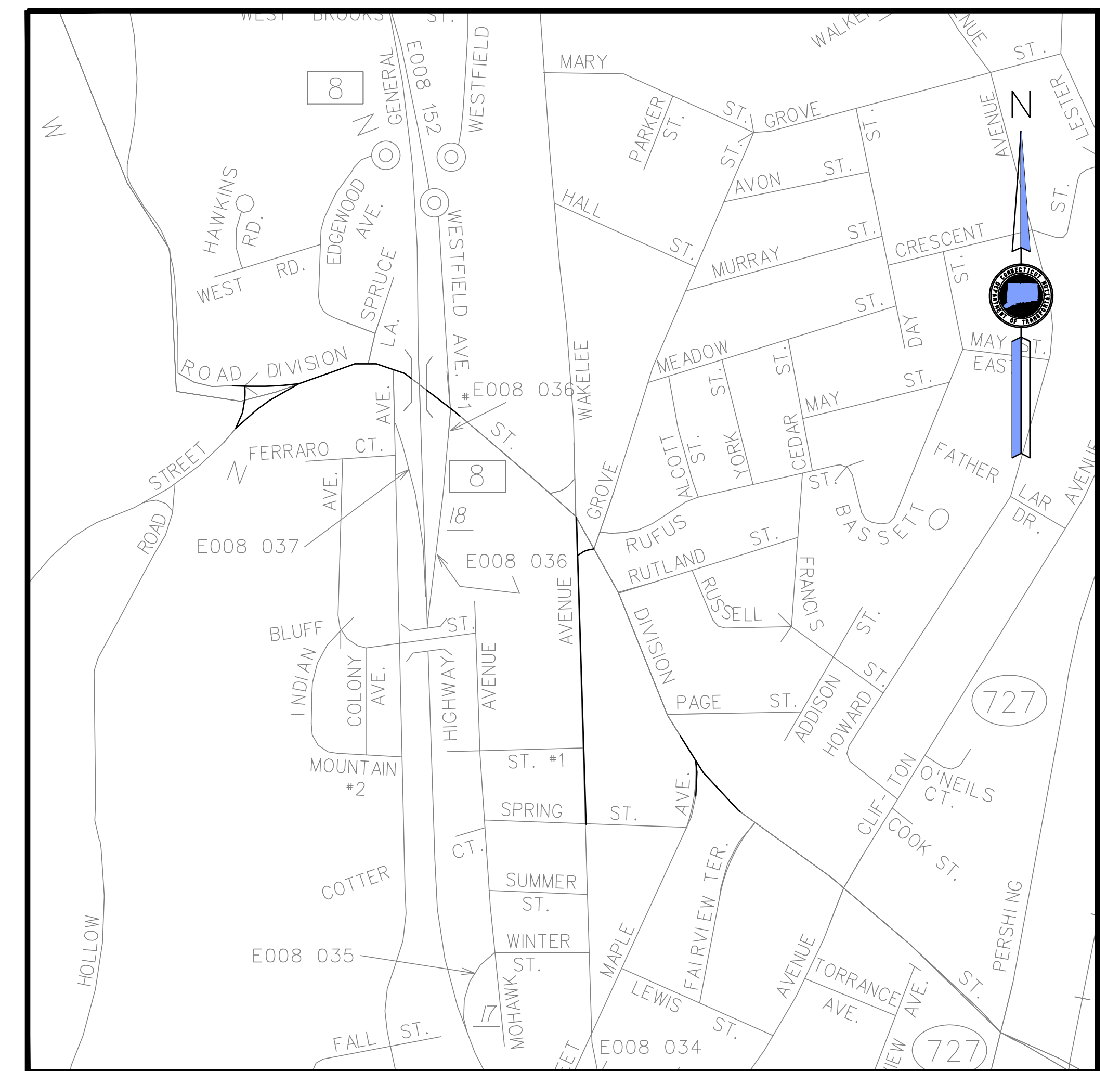
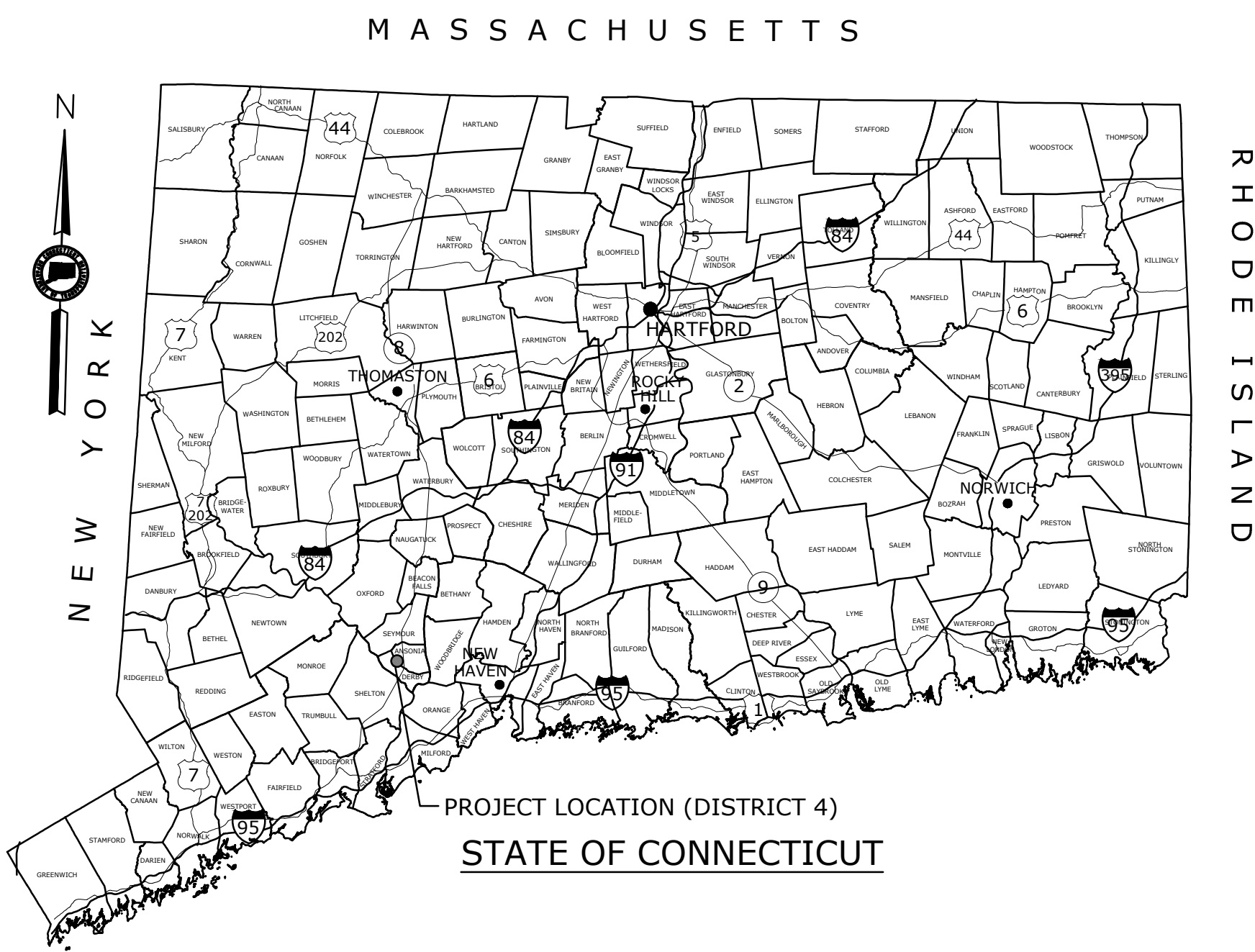

GENERAL NOTES:

1. CONSTRUCTION SPECIFICATIONS:
 Connecticut Department of Transportation, Standard Specifications for Roads, Bridges and Incidental Construction, Form 819, dated 2024; Supplemental Specifications, dated January 2025; as supplemented and/or amended by City Project Technical Specifications
2. 400 FOOT GRID BASED ON CONNECTICUT COORDINATE SYSTEM N.A.D. 1983
3. VERTICAL DATUM BASED ON NGVD 1988

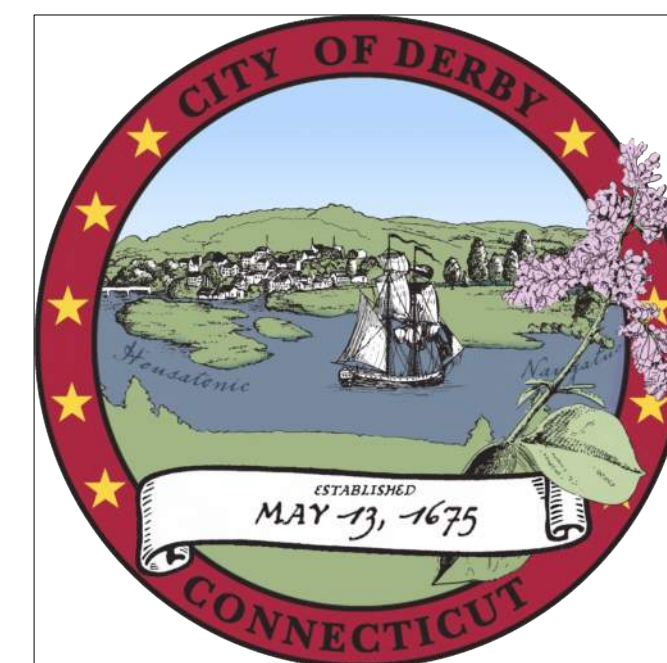

JULY 2025



LOCATION PLAN
 NOT TO SCALE

PUBLIC INFORMATION MEETING

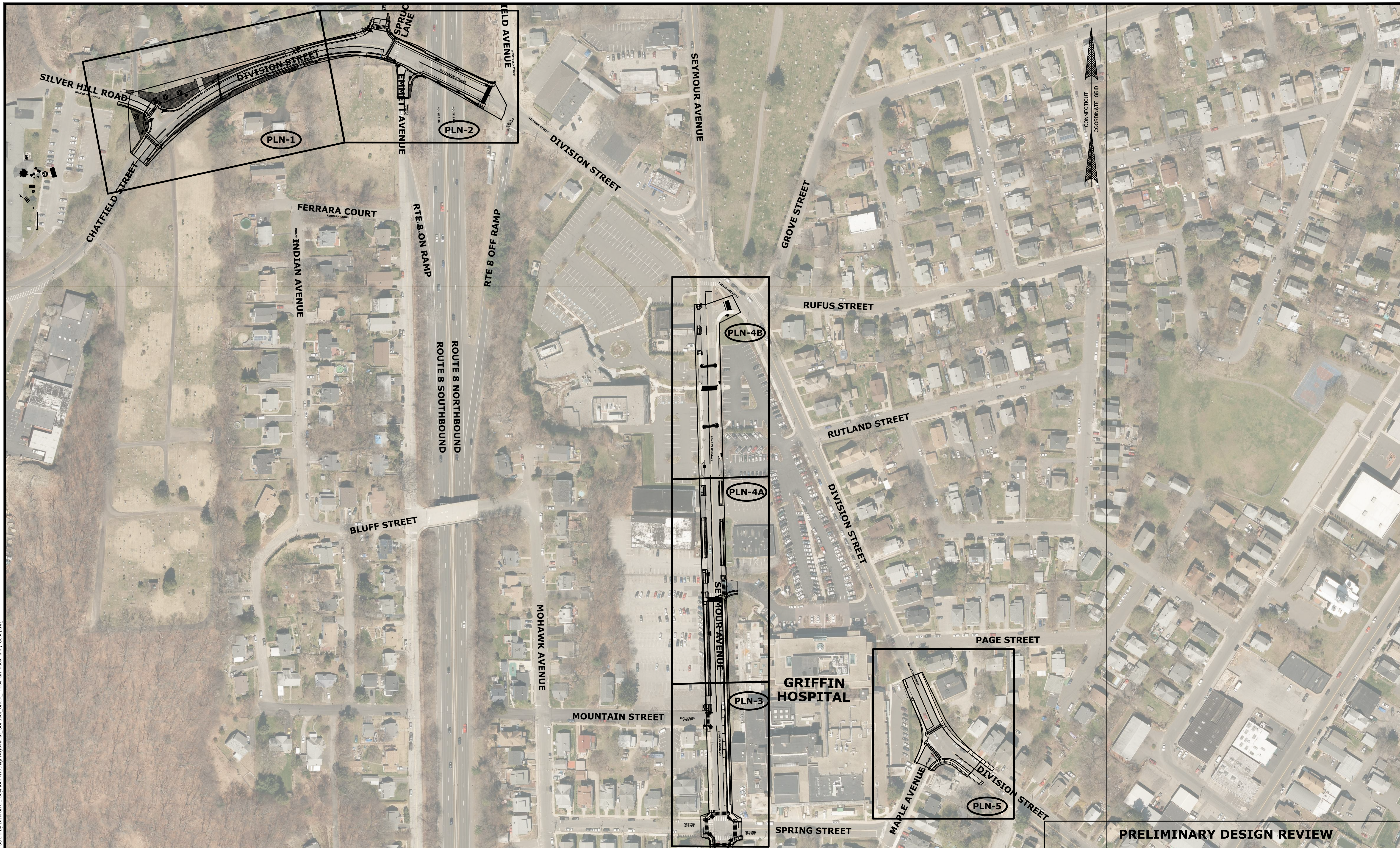

PRELIMINARY DESIGN REVIEW

REV.	DATE	REVISION DESCRIPTION	SHEET NO.

THE INFORMATION, INCLUDING ESTIMATED QUANTITIES OF WORK, SHOWN ON THESE SHEETS IS BASED ON LIMITED INVESTIGATIONS BY THE STATE AND IS IN NO WAY WARRANTED TO INDICATE THE CONDITIONS OF ACTUAL QUANTITIES OF WORK WHICH WILL BE REQUIRED.

DATE PLOTTED: 7/02/2025

DESIGNER/DRAFTER:
 CHECKED BY:
 SCALE IN FEET
 0 100 200
 SCALE 1"=100'

FILENAME:



Luchs
 CONSULTING ENGINEERS
 89 COLONY STREET MERIDEN, CT 06451
 TELEPHONE: 203-379-0320

SIGNATURE/
 BLOCK:

PROJECT TITLE:
**DIVISION STREET AND SEYMOUR AVENUE
 SAFETY IMPROVEMENTS**

TOWN: **DERBY**
 DRAWING TITLE:
INDEX PLAN

PROJECT NO.: **XXX-XXX**
 DRAWING NO.: **INP-1**
 SHEET NO.:

C:\Projects\Luchs\Projects\20199_Derby_Division St. Seymour Ave\Highways\MSA_Contract_Sheet_Files\Plan\IndexPlan (100sc).dwg

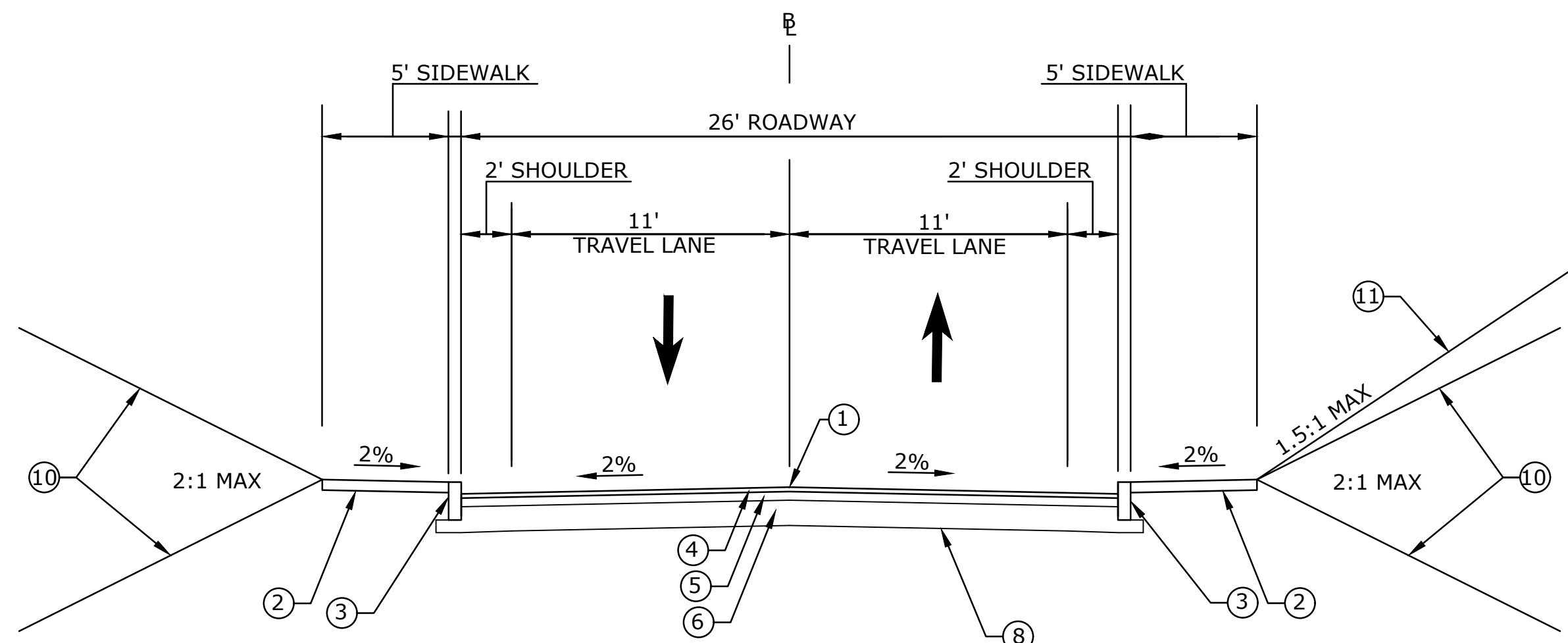

DIVISION STREET NORMAL ROADWAY SECTION
(NOT TO SCALE)

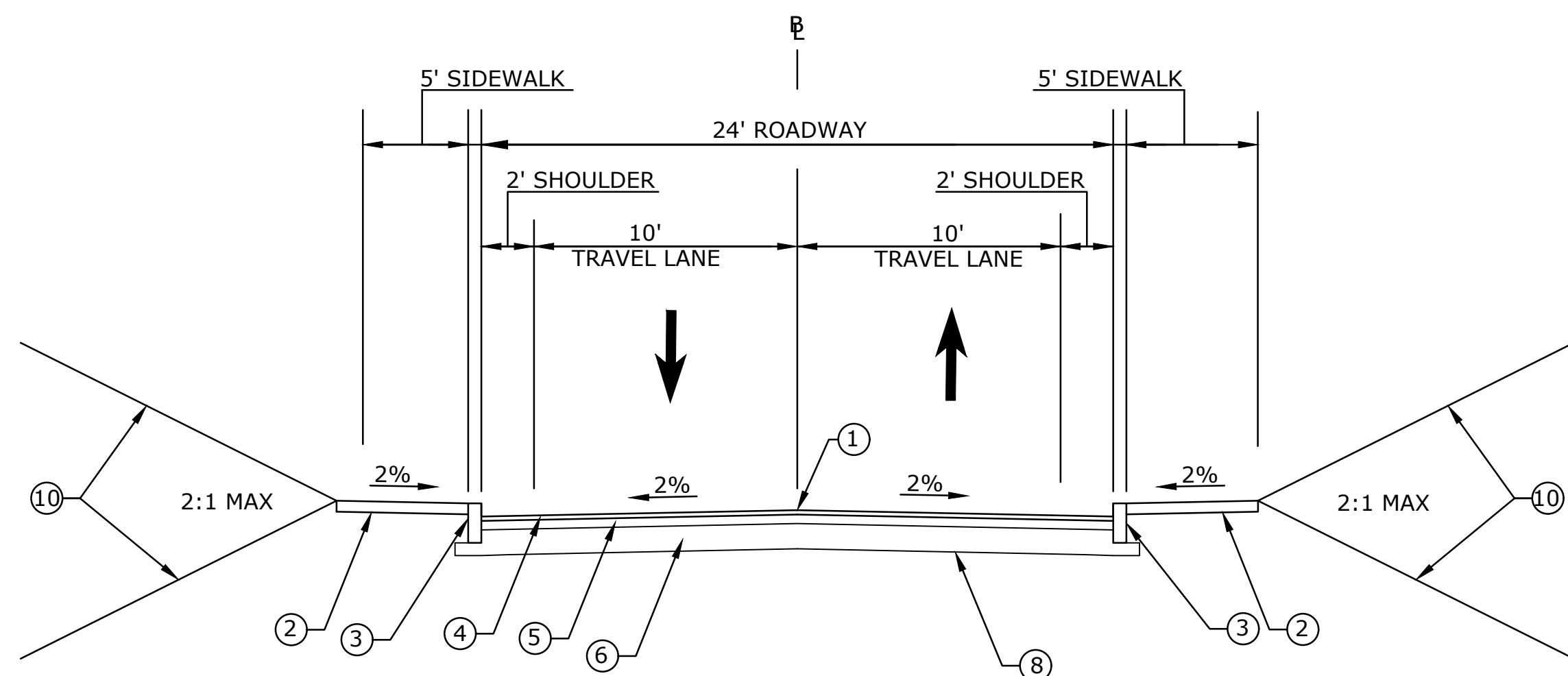

SILVER HILL ROAD NORMAL ROADWAY SECTION
(NOT TO SCALE)

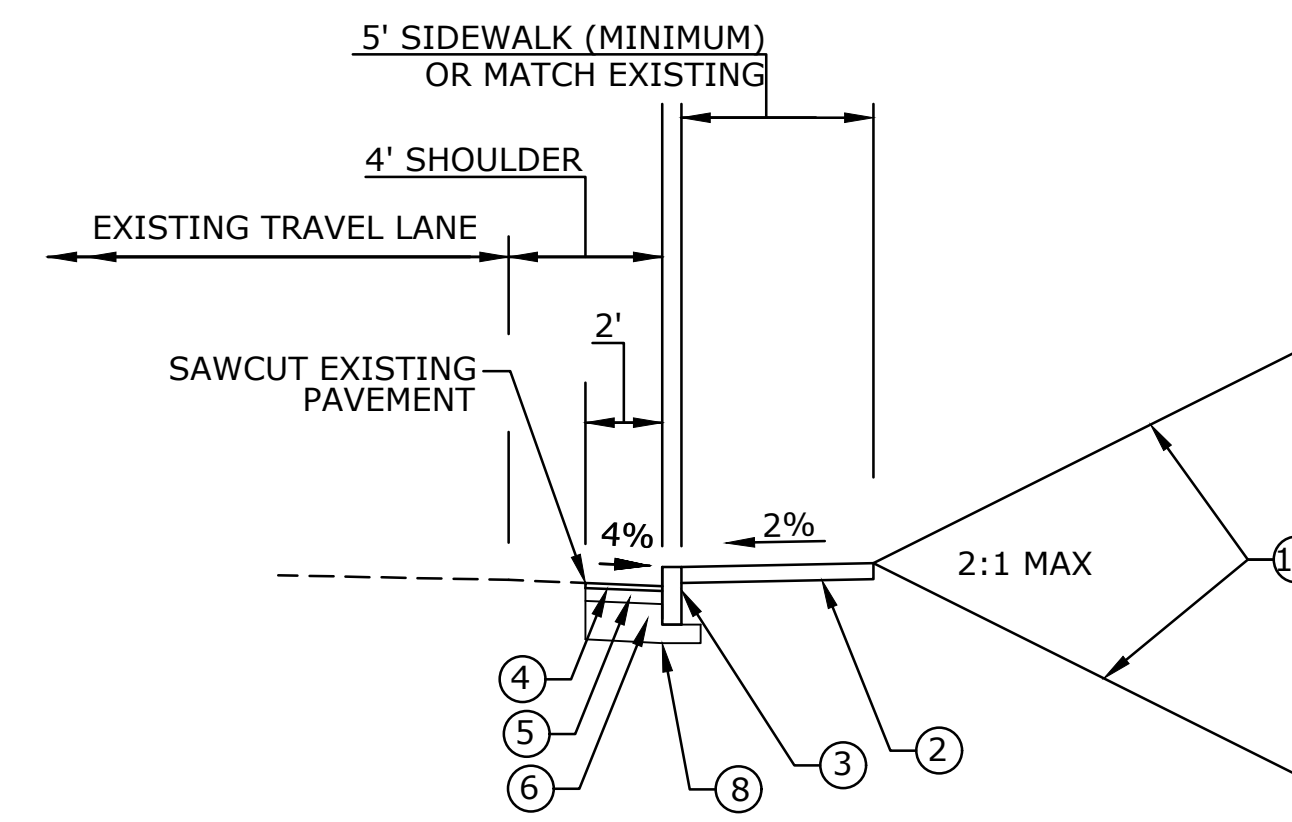

DIVISION ST, SEYMOUR AVE, MAPLE AVE PARTIAL SECTION
CONCRETE CURBING AND SIDEWALK
(NOT TO SCALE)

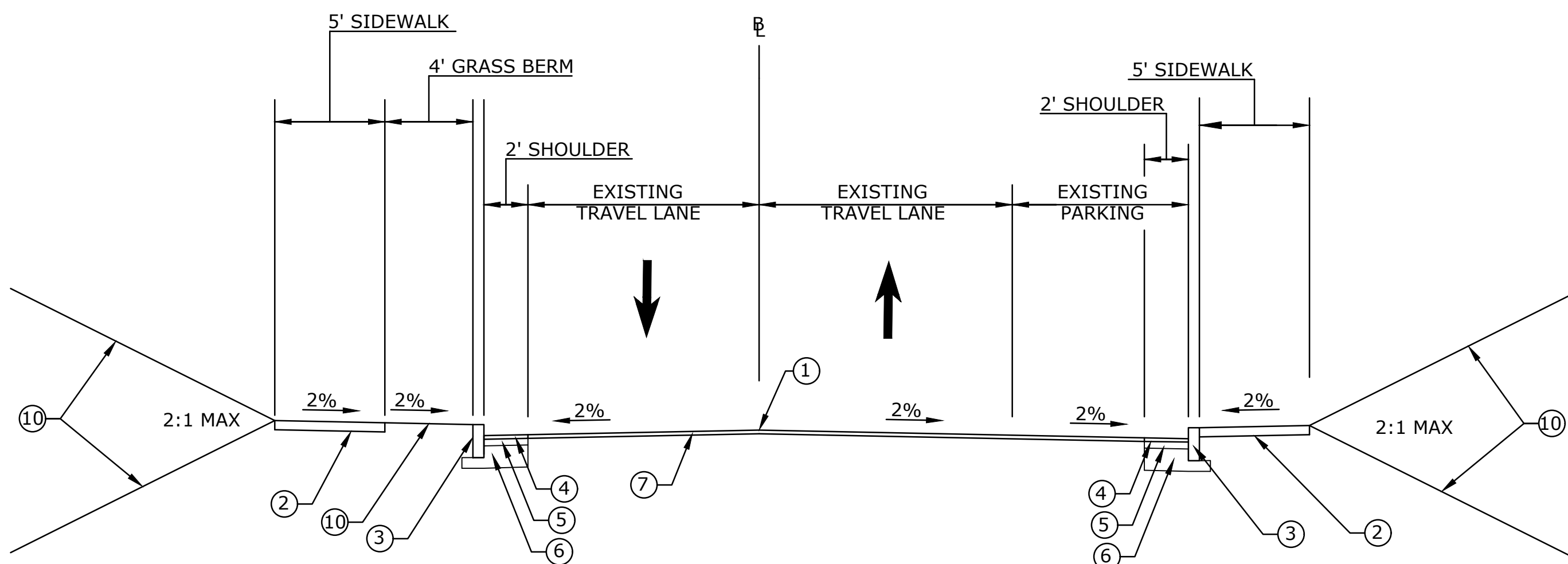

SEYMOUR AVENUE NORMAL ROADWAY SECTION
(NOT TO SCALE)

LEGEND

- ① POINT OF APPLICATION OF GRADE
- ② CONCRETE SIDEWALK
- ③ CONCRETE CURBING
- ④ 2" HMA S0.5 (TRAFFIC LEVEL 2)
- ⑤ 4" HMA S1 (TRAFFIC LEVEL 2) (PLACE IN TWO EQUAL LIFTS)
- ⑥ 12" PROCESSED AGGREGATE BASE (PLACE IN THREE EQUAL LIFTS)
- ⑦ 2" MILLING AND OVERLAY HMA S0.5 (TRAFFIC LEVEL 2)
- ⑧ FORMATION OF SUBGRADE
- ⑨ EMBANKMENT WALL (HEIGHT VARIES)
- ⑩ TOPSOIL AND TURF ESTABLISHMENT
- ⑪ MODIFIED RIPRAP

PRELIMINARY DESIGN REVIEW

C:\Projects\Luchs\Projects\20199_Derby Division St, Seymour Ave\Highways\MSA_Contract_Sheet_Files\Plan\Highway plan.dwg

REV.	DATE	REVISION DESCRIPTION	SHEET NO.	DATE PLOTTED:
				7/02/2025

THE INFORMATION, INCLUDING ESTIMATED QUANTITIES OF WORK, SHOWN ON THESE SHEETS IS BASED ON LIMITED INVESTIGATIONS BY THE STATE AND IS IN NO WAY WARRANTED TO INDICATE THE CONDITIONS OF ACTUAL QUANTITIES OF WORK WHICH WILL BE REQUIRED.

DESIGNER/DRAFTER:
CHECKED BY:
SCALE AS NOTED

FILENAME:



89 COLONY STREET MERIDEN, CT 06451
TELEPHONE: 203-379-0320

SIGNATURE/
BLOCK:

PROJECT TITLE:
**DIVISION STREET & SEYMOUR AVENUE
SAFETY IMPROVEMENTS**

TOWN:
DERBY & ANSONIA
DRAWING TITLE:
TYPICAL SECTIONS

PROJECT NO.:
20-199
DRAWING NO.:
TYP-1
SHEET NO.:

GENERAL NOTES

1. PLACE SEDIMENTATION CONTROL SYSTEM AT ALL CATCH BASINS WITHIN THE PROJECT LIMITS. (SEE DETAILS ON DRAWING MDS-1)
2. CONTRACTOR SHALL RESET ALL WATER AND GAS UTILITY GATE VALVES WITHIN THE PROJECT LIMITS. TO BE PAID FOR UNDER ITEM 1302061 - ADJUST GATE BOX (WATER) AND ITEM 1302062 - ADJUST GATE BOX (GAS).
3. CONTRACTOR SHALL PROTECT OR RESET ALL PROPERTY MARKERS, CONTROL POINTS, AND BENCH MARKS WITHIN THE PROJECT LIMITS.

GENERAL NOTES (CONT.)

4. ALL DRIVEWAY APRONS SHALL BE CONSTRUCTED WITH A MINIMUM 3 FT CURB RETURN RADIUS. (SEE CT STANDARD DETAIL SHEET HW-921_01)
5. ALL EXISTING SIDEWALK RAMPS NOT IN CONFORMANCE WITH CURRENT ADA STANDARDS SHALL BE REMOVED WITHIN THE PROJECT LIMITS.
6. THIS PROJECT SHALL INCLUDE THE REMOVAL OF ALL TREES WITHIN THE TOWN RIGHT OF WAY UNLESS SPECIFIED OTHERWISE. THIS WORK SHALL BE PAID FOR UNDER ITEM 0201001 - CLEARING AND GRUBBING.
7. THE CONTRACTOR SHALL BACKFILL ALL OPEN TRENCHES PRIOR TO THE END OF EACH WORK DAY.

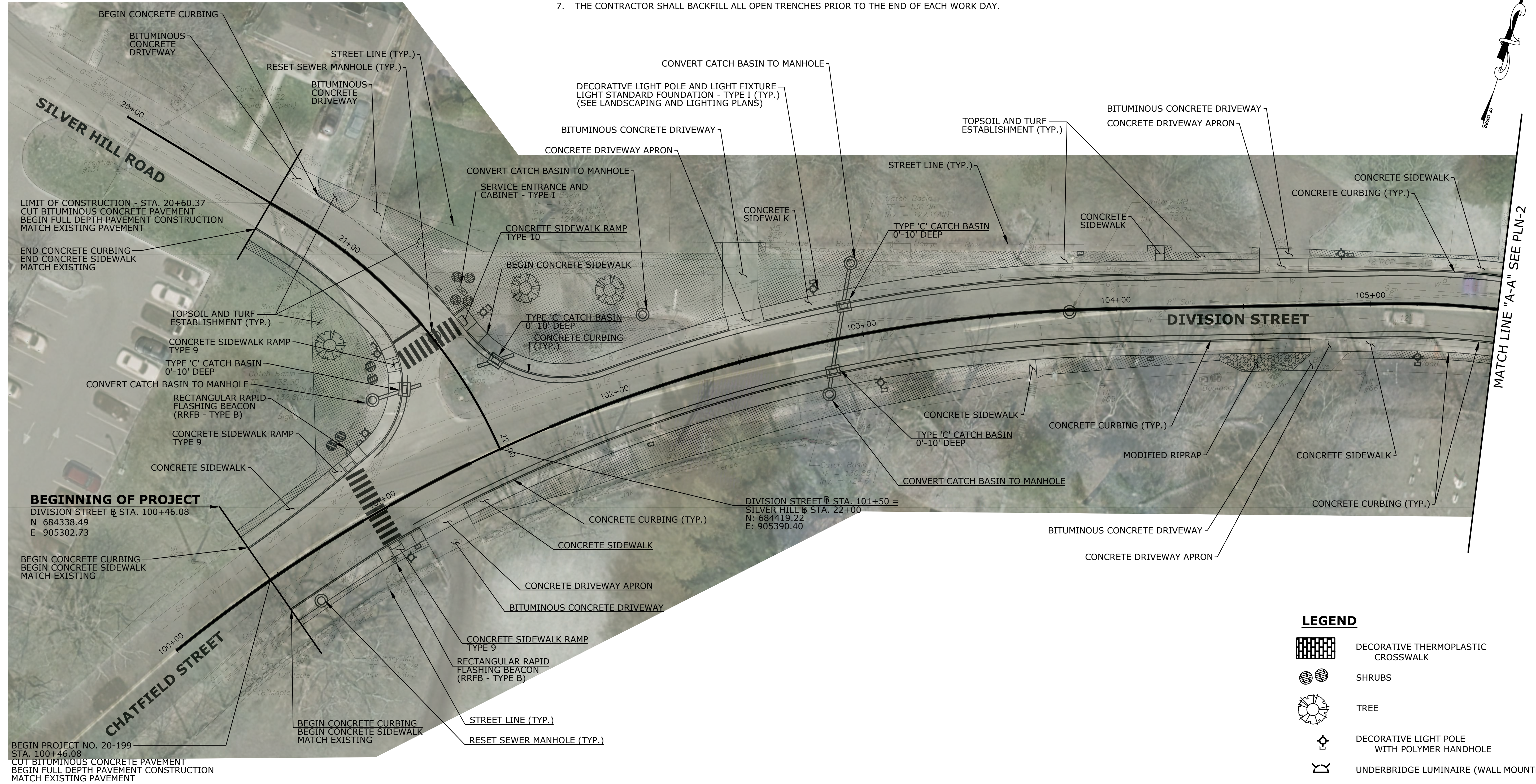







BEGINNING OF PROJECT
 DIVISION STREET @ STA. 100+46.08
 N 684338.49
 E 905302.73

DIVISION STREET @ STA. 101+50 =
 SILVER HILL @ STA. 22+00
 N: 684419.22
 E: 905390.40

BEGIN PROJECT NO. 20-199
 STA. 100+46.08
 CUT BITUMINOUS CONCRETE PAVEMENT
 BEGIN FULL DEPTH PAVEMENT CONSTRUCTION
 MATCH EXISTING PAVEMENT

LEGEND

-  DECORATIVE THERMOPLASTIC CROSSWALK
-  SHRUBS
-  TREE
-  DECORATIVE LIGHT POLE WITH POLYMER HANDHOLE
-  UNDERBRIDGE LUMINAIRE (WALL MOUNTED)
-  SERVICE ENTRANCE AND CABINET - TYPE 1





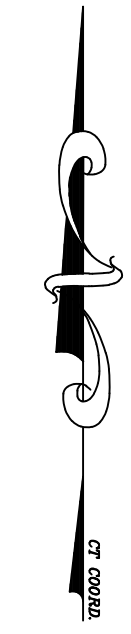
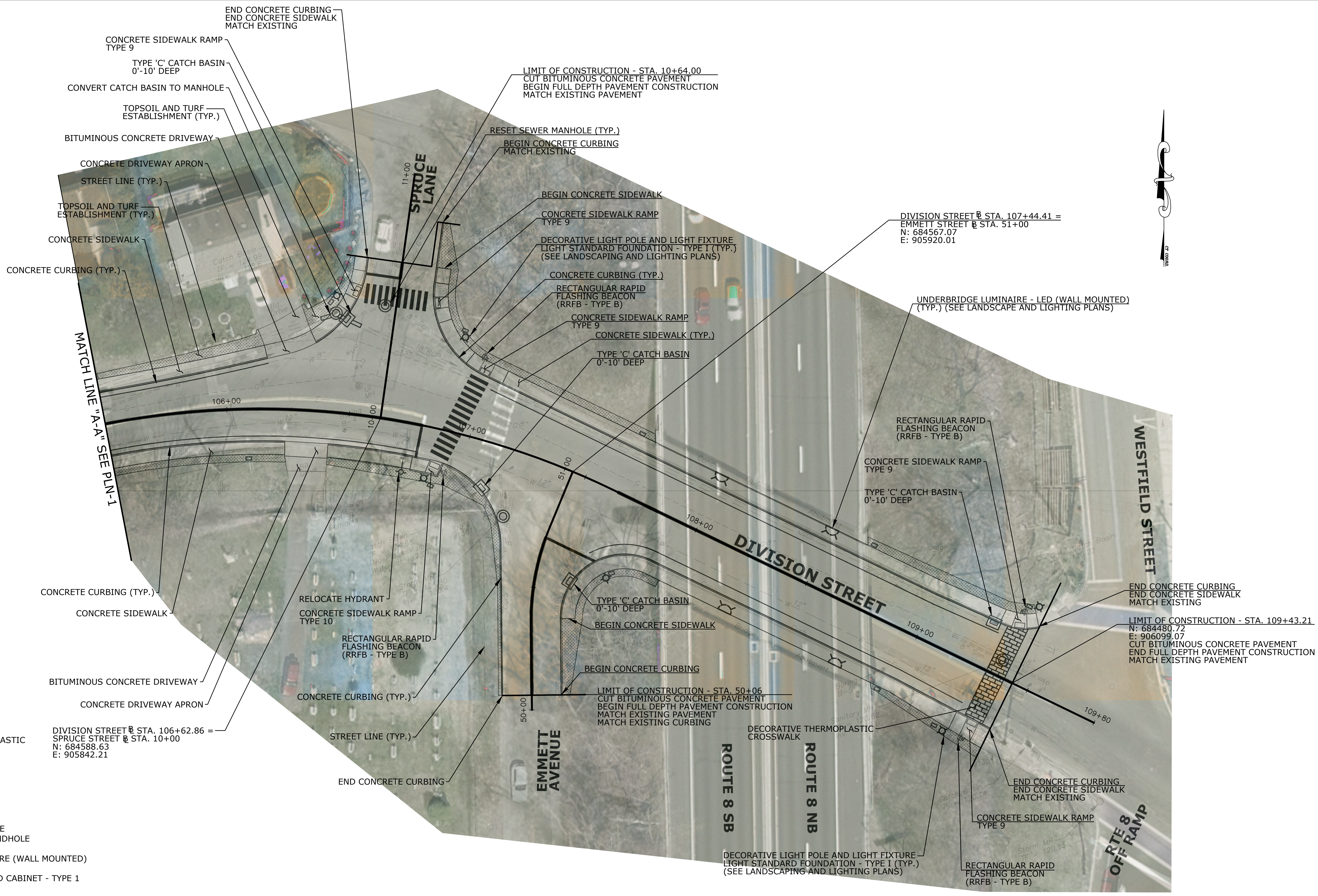

PRELIMINARY DESIGN REVIEW

THE INFORMATION, INCLUDING ESTIMATED QUANTITIES OF WORK, SHOWN ON THESE SHEETS IS BASED ON LIMITED INVESTIGATIONS BY THE STATE AND IS IN NO WAY WARRANTED TO INDICATE THE CONDITIONS OF ACTUAL QUANTITIES OF WORK WHICH WILL BE REQUIRED.		DESIGNER/DRAFTER: CHECKED BY: SCALE IN FEET SCALE 1"=20' DATE PLOTTED: 7/02/2025	 Luchs CONSULTING ENGINEERS 89 COLONY STREET MERIDEN, CT 06451 TELEPHONE: 203-379-0320	SIGNATURE/ BLOCK:	PROJECT TITLE: DIVISION STREET & SEYMOUR AVENUE SAFETY IMPROVEMENTS	TOWN: DERBY & ANSONIA	PROJECT NO.: 20-199 DRAWING NO.: PLN-1 SHEET NO.:
REV.	DATE	REVISION DESCRIPTION	SHEET NO.				

G:\Projects\Luchs\Projects\20199 Derby Division St. Seymour Ave\Highways\MSA - Contract_Sheet_Files\Plan\Highway plan.dwg



LEGEND

-  DECORATIVE THERMOPLASTIC CROSSWALK
-  SHRUBS
-  TREE
-  DECORATIVE LIGHT POLE WITH POLYMER HANDHOLE
-  UNDERBRIDGE LUMINAIRE (WALL MOUNTED)
-  SERVICE ENTRANCE AND CABINET - TYPE 1

DIVISION STREET @ STA. 106+62.86 =
 SPRUCE STREET @ STA. 10+00
 N: 684588.63
 E: 905842.21

END CONCRETE CURBING
 END CONCRETE SIDEWALK
 MATCH EXISTING
 LIMIT OF CONSTRUCTION - STA. 109+43.21
 N: 684480.72
 E: 906099.07
 CUT BITUMINOUS CONCRETE PAVEMENT
 END FULL DEPTH PAVEMENT CONSTRUCTION
 MATCH EXISTING PAVEMENT

C:\Projects\Luchs\Projects\20199_Derby_Division St. Seymour Ave\Highways\MSA - Contract_Sheet_Files\Plan\Highway plan.dwg

PRELIMINARY DESIGN REVIEW

REV.	DATE	REVISION DESCRIPTION	SHEET NO.

THE INFORMATION, INCLUDING ESTIMATED QUANTITIES OF WORK, SHOWN ON THESE SHEETS IS BASED ON LIMITED INVESTIGATIONS BY THE STATE AND IS IN NO WAY WARRANTED TO INDICATE THE CONDITIONS OF ACTUAL QUANTITIES OF WORK WHICH WILL BE REQUIRED.

DESIGNER/DRAFTER:
 CHECKED BY:
 SCALE IN FEET
 0 20 40
 SCALE 1"=20'

Luchs
 CONSULTING ENGINEERS
89 COLONY STREET MERIDEN, CT 06451
 TELEPHONE: 203-379-0320

SIGNATURE/
 BLOCK:

PROJECT TITLE:
**DIVISION STREET & SEYMOUR AVENUE
 SAFETY IMPROVEMENTS**

TOWN:
DERBY & ANSONIA

DRAWING TITLE:
ROADWAY PLAN

PROJECT NO.:
20-199

DRAWING NO.:
PLN-2



SHEET NO.:

GENERAL NOTES

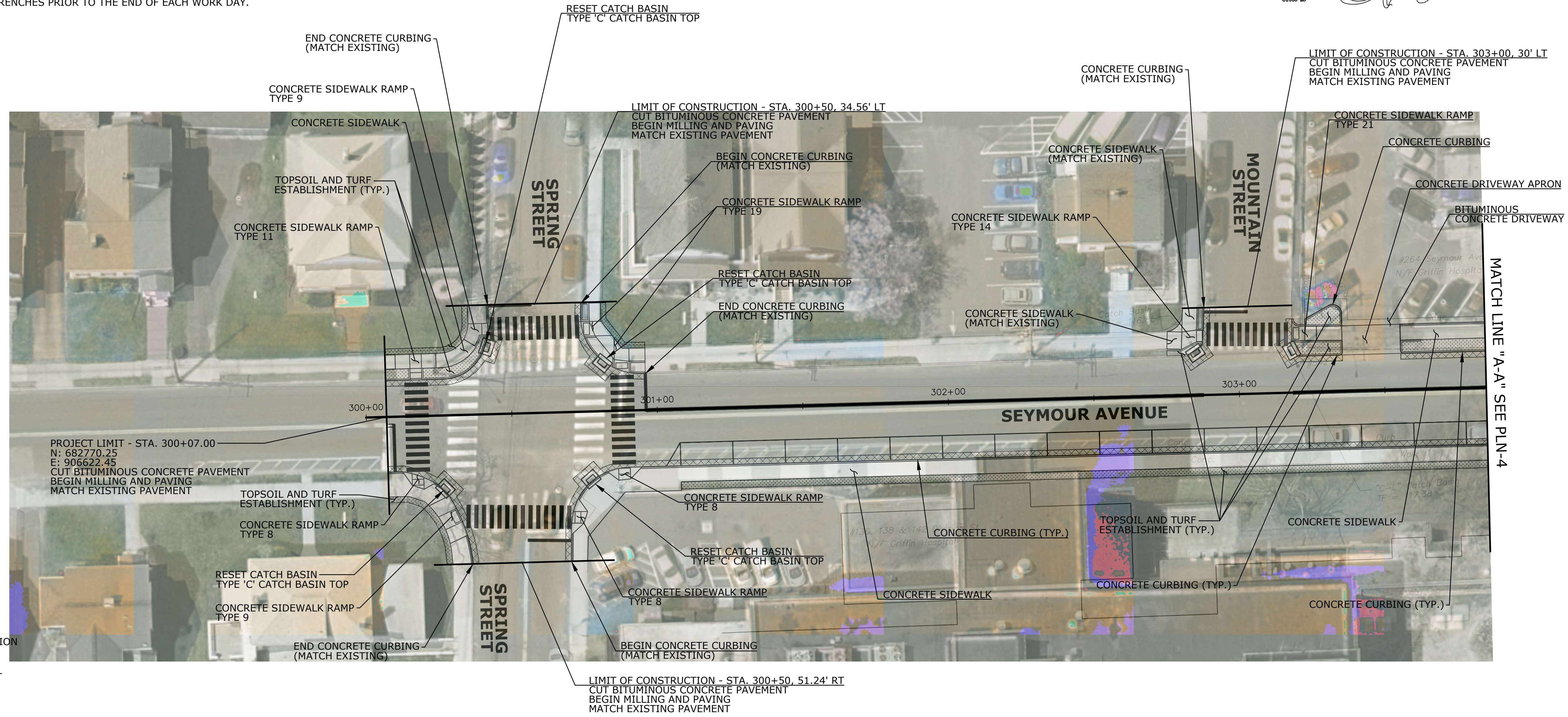
1. PLACE SEDIMENTATION CONTROL SYSTEM AT ALL CATCH BASINS WITHIN THE PROJECT LIMITS. (SEE DETAILS ON DRAWING MDS-1)
2. CONTRACTOR SHALL RESET ALL WATER AND GAS UTILITY GATE VALVES WITHIN THE PROJECT LIMITS. TO BE PAID FOR UNDER ITEM 1302061 - ADJUST GATE BOX (WATER) AND ITEM 1302062 - ADJUST GATE BOX (GAS).
3. CONTRACTOR SHALL PROTECT OR RESET ALL PROPERTY MARKERS, CONTROL POINTS, AND BENCH MARKS WITHIN THE PROJECT LIMITS.
4. ALL DRIVEWAY APRONS SHALL BE CONSTRUCTED WITH A MINIMUM 3 FT CURB RETURN RADIUS. (SEE CT STANDARD DETAIL SHEET HW-921_01)
5. ALL EXISTING SIDEWALK RAMP NOT IN CONFORMANCE WITH CURRENT ADA STANDARDS SHALL BE REMOVED WITHIN THE PROJECT LIMITS.
6. THIS PROJECT SHALL INCLUDE THE REMOVAL OF ALL TREES WITHIN THE TOWN RIGHT OF WAY UNLESS SPECIFIED OTHERWISE. THIS WORK SHALL BE PAID FOR UNDER ITEM 0201001 - CLEARING AND GRUBBING.
7. THE CONTRACTOR SHALL BACKFILL ALL OPEN TRENCHES PRIOR TO THE END OF EACH WORK DAY.

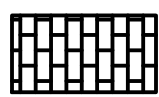
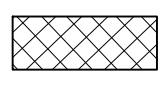

LEGEND

-  DECORATIVE THERMOPLASTIC CROSSWALK
-  FULL-DEPTH PAVEMENT CONSTRUCTION
-  TOPSOIL AND TURF ESTABLISHMENT

PRELIMINARY DESIGN REVIEW

REV.	DATE	REVISION DESCRIPTION	SHEET NO.

THE INFORMATION, INCLUDING ESTIMATED QUANTITIES OF WORK, SHOWN ON THESE SHEETS IS BASED ON LIMITED INVESTIGATIONS BY THE STATE AND IS IN NO WAY WARRANTED TO INDICATE THE CONDITIONS OF ACTUAL QUANTITIES OF WORK WHICH WILL BE REQUIRED.

DATE PLOTTED: 7/02/2025

DESIGNER/DRAFTER:
CHECKED BY:
SCALE IN FEET
SCALE 1"=20'



89 COLONY STREET MERIDEN, CT 06451
TELEPHONE: 203-379-0320

FILENAME:

SIGNATURE/
BLOCK:

PROJECT TITLE:
**DIVISION STREET & SEYMOUR AVENUE
SAFETY IMPROVEMENTS**

TOWN:
DERBY & ANSONIA

DRAWING TITLE:
ROADWAY PLAN



PROJECT NO.:
20-199

DRAWING NO.:
PLN-3

SHEET NO.:

C:\Projects\Luchs\Projects\20199_Derby Division St. Seymour Ave\Highways\MSA - Contract_Sheet_Files\Plan\Highway plan.dwg

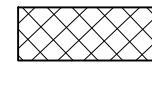
LEGEND

-  DECORATIVE THERMOPLASTIC CROSSWALK
-  FULL-DEPTH PAVEMENT CONSTRUCTION
-  TOPSOIL AND TURF ESTABLISHMENT

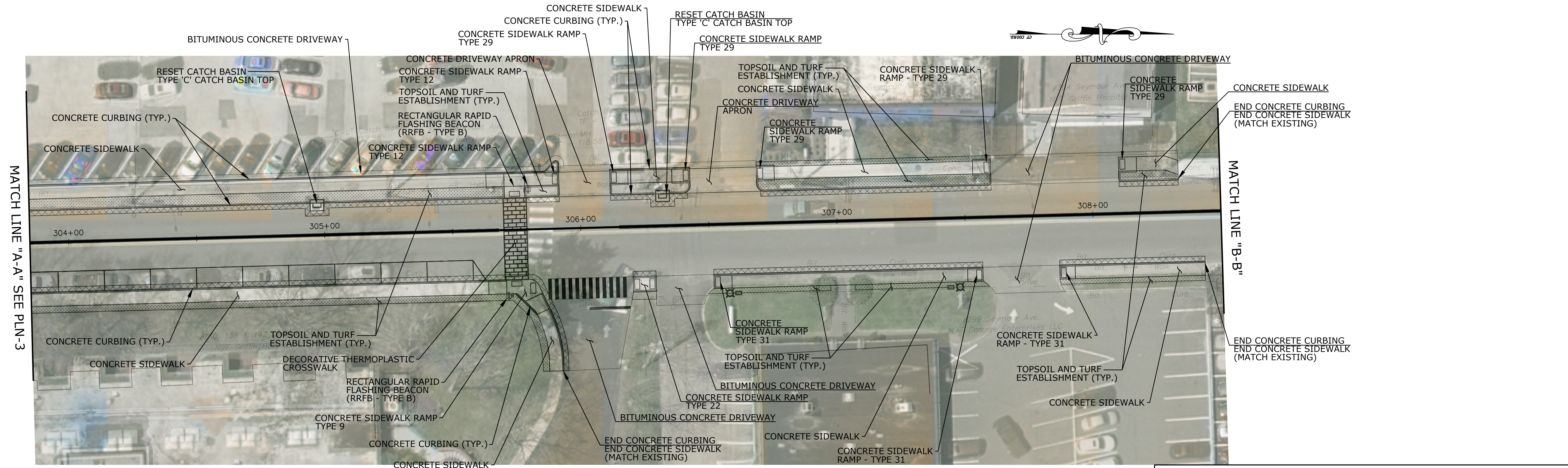
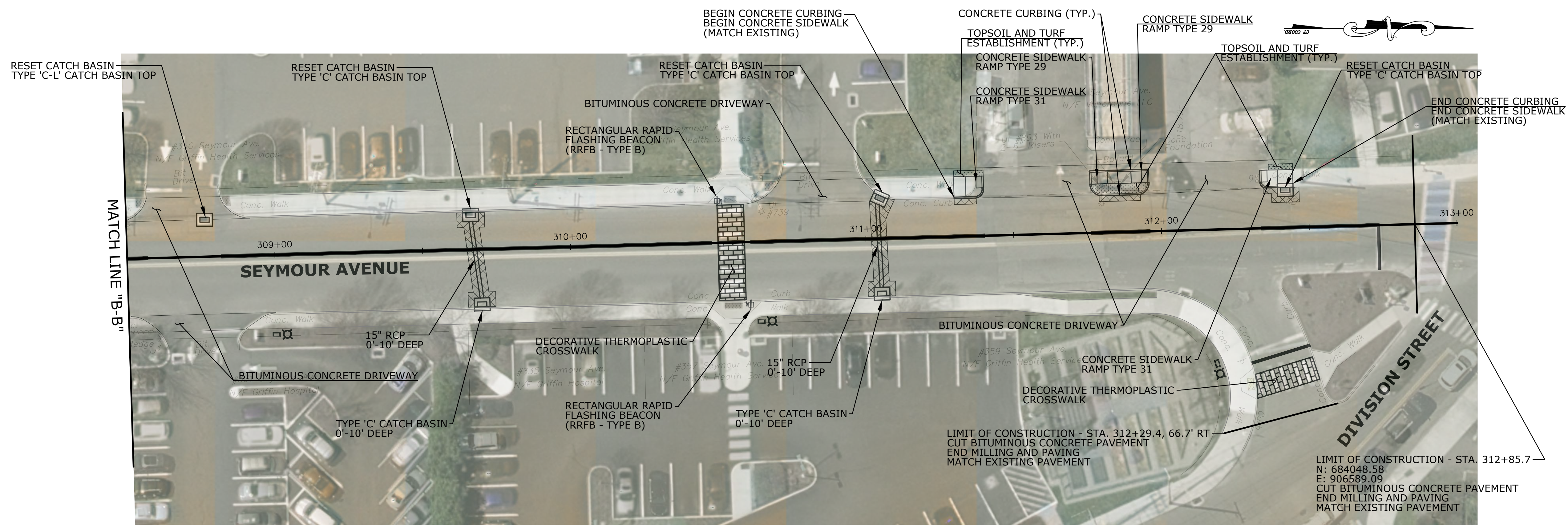

PRELIMINARY DESIGN REVIEW

G:\Projects\Luchs\Projects\20199 Derby Division St. Seymour Ave\Highways\MSA - Contract_Sheet_Files\Plan\Highway plan.dwg

REV.	DATE	REVISION DESCRIPTION	SHEET NO.	DATE PLOTTED:
				7/02/2025

THE INFORMATION, INCLUDING ESTIMATED QUANTITIES OF WORK, SHOWN ON THESE SHEETS IS BASED ON LIMITED INVESTIGATIONS BY THE STATE AND IS IN NO WAY WARRANTED TO INDICATE THE CONDITIONS OF ACTUAL QUANTITIES OF WORK WHICH WILL BE REQUIRED.

DESIGNER/DRAFTER:
CHECKED BY:
SCALE IN FEET
SCALE 1"=20'



Luchs
CONSULTING ENGINEERS
89 COLONY STREET MERIDEN, CT 06451
TELEPHONE: 203-379-0320

SIGNATURE/
BLOCK:

PROJECT TITLE:
**DIVISION STREET & SEYMOUR AVENUE
SAFETY IMPROVEMENTS**

TOWN:
DERBY & ANSONIA
DRAWING TITLE:
ROADWAY PLAN

PROJECT NO.:
20-199
DRAWING NO.:
PLN-4
SHEET NO.:

BEGIN CONCRETE CURBING
BEGIN CONCRETE SIDEWALK
(MATCH EXISTING)

LIMIT OF CONSTRUCTION - STA. 125+54.00
N: 683162.02
E: 907057.82
CUT BITUMINOUS CONCRETE PAVEMENT
BEGIN MILLING AND PAVING
MATCH EXISTING PAVEMENT

BEGIN CONCRETE CURBING
BEGIN CONCRETE SIDEWALK
(MATCH EXISTING)

CONCRETE SIDEWALK
RAMP TYPE 31

CONCRETE SIDEWALK
(TYP.)

CONCRETE SIDEWALK
RAMP TYPE 31

CONCRETE SIDEWALK
(TYP.)

CONCRETE SIDEWALK
RAMP TYPE 9

CONCRETE CURBING (TYP.)

DIVISION STREET @ STA. 127+12.98 =
MAPLE STREET @ STA. 73+00
N: 683020.26
E: 907128.44

CONCRETE CURBING (TYP.)

CONCRETE SIDEWALK
RAMP TYPE 8

CONCRETE DRIVEWAY APRON

STREET LINE (TYP.)

CONCRETE SIDEWALK
RAMP TYPE 8

CONCRETE DRIVEWAY APRON

STREET LINE (TYP.)

END CONCRETE CURBING
END CONCRETE SIDEWALK
(MATCH EXISTING)

LIMIT OF CONSTRUCTION - STA. 72+21.8
CUT BITUMINOUS CONCRETE PAVEMENT
END MILLING AND PAVING
MATCH EXISTING PAVEMENT

CONCRETE SIDEWALK
RAMP TYPE 11

LIMIT OF CONSTRUCTION - STA. 128+46.03
N: 682935.63
E: 907230.78
CUT BITUMINOUS CONCRETE PAVEMENT
END MILLING AND PAVING
MATCH EXISTING PAVEMENT

TOPSOIL AND TURF
ESTABLISHMENT (TYP.)

BEGIN CONCRETE SIDEWALK
(MATCH EXISTING)

CONCRETE DRIVEWAY APRON
BITUMINOUS CONCRETE DRIVEWAY

STREET LINE (TYP.)

BEGIN CONCRETE CURBING
(MATCH EXISTING)

PRELIMINARY DESIGN REVIEW

C:\Projects\Luchs\Projects\20199 Derby Division St. Seymour Ave\Highways\MSA - Contract_Sheet_Files\Plan\Highway plan.dwg

REV.	DATE	REVISION DESCRIPTION	SHEET NO.	DATE PLOTTED:
				7/02/2025

THE INFORMATION, INCLUDING ESTIMATED QUANTITIES OF WORK, SHOWN ON THESE SHEETS IS BASED ON LIMITED INVESTIGATIONS BY THE STATE AND IS IN NO WAY WARRANTED TO INDICATE THE CONDITIONS OF ACTUAL QUANTITIES OF WORK WHICH WILL BE REQUIRED.

DESIGNER/DRAFTER:
CHECKED BY:
SCALE IN FEET
SCALE 1"=20'



Luchs
CONSULTING ENGINEERS
89 COLONY STREET MERIDEN, CT 06451
TELEPHONE: 203-379-0320

SIGNATURE/
BLOCK:

PROJECT TITLE:
**DIVISION STREET & SEYMOUR AVENUE
SAFETY IMPROVEMENTS**

TOWN:
DERBY & ANSONIA
DRAWING TITLE:
ROADWAY PLAN

PROJECT NO.:
20-199
DRAWING NO.:
PLN-5
SHEET NO.: